

# SEWERAGE SYSTEM **Standard Practice Manual**

**Version 2**

*21<sup>st</sup> September 2007*

*Prepared for:*

Ministry of Health  
Population Health and Wellness  
Health Protection  
4th Floor, 1515 Blanshard Street  
Victoria, BC, V8W 3C8

*Prepared by:*

British Columbia Onsite Sewage Association  
(BCOSSA)  
Box 47071  
Victoria, BC, V9B 5T2

**Technical Review Committee of the British Columbia OnSite Sewage Association**

Chair: Ian Ralston BSc pgDipAgEng ROWP

Members: Michael Payne PEng, PGeo, Derek Smith B.Sc., R.P.Bio.ROWP , Darryl Brizan PEng., Ron Hein ROWP, Frank Hay ROWP, Karen Halliday ROWP.

Resource persons: John Rowse B.A.A., C.P.H.I.C., M.A , George Giles PEng, Ron McMurtie PEng

## **SPM Sunset Clause**

Sections 8(3) and 9(2) of the Sewerage System Regulation (SSR) outline that the Standard Practice Manual (SPM) by which the Authorized Person may have regard, can be amended from time to time.

The new September 2007, SPM Version 2 brings into effect new amendments. This affects all previously issued versions by the BC Ministry of Health, Population Health and Wellness, Health Protection Branch, including the latest September 2006 version on the Ministry of Health website.

To allow industry a transition period from the old manual to the new, the previous September 2006 version will not formally sunset until midnight December 31, 2007.

Immediate use of the new version is highly recommended, but during this transition period both versions are in effect and it is understood the Authorized Person can use either version.

On January 1, 2008, only the new September 2007, SPM Version 2 will be in effect.

# Table of Contents

<b>1.1 Purpose and Content of the Sewerage System Standard Practice Manual.....</b>	<b>1</b>
1.1.1 Overview of Sewerage System Regulation.....	1
1.1.2 Content — SPM STANDARDS.....	3
1.2.1.1 Standards.....	3
Part 2 critical standards.....	3
Part 3 significant standards and guidelines.....	4
1.2.1.2 Linked standards.....	4
1.1.3 Organization of the manual.....	5
1.1.4 Application of Standard Practice by Authorized Persons.....	5
<b>1.2 Administrative.....</b>	<b>6</b>
1.2.1 Administrative Process.....	6
1.2.2 Circumstances Where HA Could Return AP Filing.....	7
1.2.3 Filing Notification Referrals.....	7
1.2.4 Privacy.....	8
1.2.5 Other Administrative Jurisdictions.....	8
1.2.6 Restrictive Covenants.....	8
1.2.7 Use of Adjacent Property.....	8
1.2.8 Easements and Covenants.....	9
1.2.9 Repairs and Replacements, new uses of systems.....	9
1.9.2.1 Component Repair or Replacement.....	9
1.9.2.2 System Repair or Replacement.....	10
1.9.2.3 New uses of an existing system.....	10
1.2.10 Seasonal Dwellings — No Hydro Connection, Isolated Areas.....	11
1.2.11 Multiple Homes on Same Property.....	11
<b>1.3 Roles and Responsibilities.....</b>	<b>11</b>
1.3.1 Health Authority.....	11
1.3.2 Authorized Person.....	12
1.3.3 Sewerage System Owner.....	13
<b>2.1 Critical Standards.....</b>	<b>15</b>
2.1.1 Base Performance Standards.....	15
2.1.2 Part 2 — Critical Standards.....	15
2.1.2.1 Linked standards.....	16
2.1.3 Organization and Use of Part 2.....	16
<b>2.2 Daily Design Flow Selection (DDF).....</b>	<b>17</b>
2.2.1 Daily Design Flow Rates for Residences.....	17
2.2.1.1 Standard Method.....	18
2.2.1.2 Secondary method (special cases).....	19
2.2.1.3 Minimum Daily Design Flow Rates for Facilities.....	20
Non-Residential Waste Design Flow Tables.....	21
Other Facility Daily Design Flows.....	26
2.2.2 Flow Reduction Devices — Mass Loading.....	27

2.2.3	Garbage Grinders (Garburators) .....	27
<b>2.3</b>	<b>Determination of Treatment and Dispersal System Needs .....</b>	<b>27</b>
2.3.1	Process Selection .....	27
2.3.2	Soil and Site Investigation Standards .....	27
2.3.2.1	Soils and water table investigation .....	27
2.3.2.2	Site investigation report .....	29
2.3.3	Vertical and Horizontal Separation Standards — Boundary Performance.....	30
2.3.3.1	Performance Standards .....	30
2.3.3.2	Vertical Separation (VS).....	30
	Vertical Separation Standards.....	30
	Increasing Vertical Separation.....	31
	Vertical Separation — Trench and Bed Systems.....	32
	Vertical Separation and Sand Depth for Sand Mounds and Sand-lined Trenches	33
2.3.3.3	Horizontal separation (Setbacks) .....	34
	Horizontal Setback Distances for Critical Setbacks .....	34
	Reduction or Increase in Setback to Source of Drinking Water or Fresh Water	
	.....	36
	Horizontal Setback for Other Boundaries.....	37
	Sand Mounds and Sand-lined Trenches — Horizontal Setbacks .....	38
2.3.4	Hydraulic Loading Rate (HLR) Standards .....	38
2.3.4.1	Seepage bed loading rates.....	39
2.3.4.2	Sand mound and sand-lined trenches basal area hydraulic loading rates	
	.....	40
2.3.4.3	Sand media Hydraulic Loading Rate for sand mounds, and similar	
	technology.....	42
2.3.4.4	Lagoon systems.....	43
2.3.5	Soil Linear Loading Rate (LLR) Standards .....	44
2.3.5.1	Movement of effluent away from the discharge area .....	44
2.3.5.2	Soil Linear Loading Rate tables.....	44
2.3.5.3	Where LLR standards cannot be met.....	45
2.3.6	Site Capability and System Selection .....	49
2.3.6.1	Site Capability.....	49
2.3.6.2	Site Capability classification (limiting conditions) for specific types of	
	systems.....	51
2.3.6.3	Flood plains.....	53
<b>2.4</b>	<b>Residential Sewage and Treatment Standards .....</b>	<b>53</b>
2.4.1	Levels of Treatment .....	55
2.4.1.1	Effluent types defined in the regulation.....	55
2.4.1.2	Additional treatment .....	56
	Type 2 10/10 Effluent .....	56
2.4.2	Monitoring for Treatment Facilities and Discharge Area.....	56
<b>3.1</b>	<b>Base Performance Standards.....</b>	<b>57</b>
3.1.1	LINKED STANDARDS.....	58
<b>3.2</b>	<b>Organization of Part 3 .....</b>	<b>58</b>
<b>3.3</b>	<b>Minimum Design, Installation, Maintenance and Monitoring Standards .....</b>	<b>59</b>

3.3.1	Planning (Design)	59
3.3.1.1	Site plans	60
3.3.2	Installation	62
3.3.2.1	Post installation certification	62
3.3.3	Maintenance and Monitoring	62
3.3.3.1	Roles and responsibilities	63
	Owner	63
	Planner and Installer	63
3.3.3.2	Maintenance Provider (MP)	63
3.3.3.3	Design and installation for monitoring	64
3.3.3.4	Maintenance Plan	65
	Notice to Occupant	66
3.3.3.5	Frequency of Monitoring and Maintenance	66
	Monitoring:	68
3.3.4	Safety	69
<b>3.4</b>	<b>Site Capability and Process Selection</b>	<b>69</b>
3.4.1	Site Capability — Matching Techniques to the Site	69
3.4.1.1	Vertical separation	69
3.4.1.2	Horizontal separation	71
3.4.1.3	Soil coarse fragment content	71
3.4.1.4	Type of limiting layer	71
	For Linear Loading Rate/Effluent Flow	71
	For Vertical Separation	71
3.4.1.5	Slope	72
	Low Slopes	72
	Steep Slopes	72
	Slope Shape and Location	72
3.4.1.6	Available area	73
3.4.1.7	Climate	73
3.4.1.8	Location and type of use	74
3.4.1.9	Combined Constraints	74
<b>3.5</b>	<b>Connection to the Onsite System — Piping</b>	<b>75</b>
3.5.1.1	Connections and Piping Performance Standards	75
3.5.1.2	Connections and Piping Description and Principles of Operation	75
	Collection systems	75
3.5.1.3	Connections and Piping Design Considerations	79
	Piping	79
	Materials	79
	Ejector pumps and pumped raw wastewater conveyance	79
	Grinder Pumps	79
	Non-gravity sewer Collection systems	80
3.5.1.4	Connections and Piping Specifications and Installation Considerations	80
	Piping	80
	Sewage Ejector Pumps and Pumped Raw Wastewater Conveyance	82
3.5.1.5	Connections and Piping Maintenance and Monitoring Considerations	83

<b>3.6 Treatment Facilities .....</b>	<b>83</b>
3.6.1 Septic Tanks (Type 1) and Sewage Effluent Tanks .....	83
3.6.1.1 Type 1 Performance Standards .....	83
3.6.1.2 Type 1 Description and Principles of Operation .....	84
Septic Tank .....	84
Other Tanks .....	85
3.6.1.3 Type 1 Design Considerations .....	86
General .....	86
Shape and Size Guidelines for Septic Tank Design .....	87
Effluent Filters .....	87
Effluent Filter Access and Alarm .....	88
Septic Tank Volume Standards .....	88
Grease Interceptors .....	90
Flow Equalization (Surge Flows) .....	91
Watertightness Testing — All Tanks .....	91
3.6.1.4 Type 1 Specifications and Installation Considerations .....	92
General .....	92
Access Openings .....	92
Venting .....	93
Installation .....	93
3.6.1.5 Type 1 Maintenance and Monitoring considerations .....	94
Septic Tank Abandonment .....	95
3.6.2 Type 2 and 3 Treatment Plants .....	96
3.6.2.1 Type 2 and 3 Performance Standards .....	96
3.6.2.2 Type 2 and 3 Description and Principles of Operation .....	96
3.6.2.3 Type 2 and 3 Design considerations .....	96
3.6.2.4 Type 2 and 3 Specifications and Installation considerations .....	97
Venting .....	97
3.6.2.5 Type 2 and 3 Maintenance and Monitoring considerations .....	97
<b>3.7 Subsurface Wastewater Infiltration Systems (SWIS) .....</b>	<b>98</b>
3.7.1 Content of SWIS Section .....	98
3.7.2 SWIS General .....	99
3.7.2.1 SWIS Performance Standards .....	99
3.7.2.2 SWIS Description and Principles of Operation .....	99
3.7.2.3 SWIS Design Considerations .....	101
Site, Soil and Ecosystem Considerations .....	101
3.7.3 Trench Dispersal Technologies .....	102
3.7.3.1 Trench systems Description and Principles of Operation .....	102
3.7.3.2 Trench systems design criteria .....	103
Trench Dimensions .....	104
3.7.3.3 Trench System Specifications and Installation considerations .....	105
Aggregate .....	105
Cover .....	105
Shallow and At Grade Trenches .....	106
Construction .....	107
Aggregate (Drain Rock) Specifications .....	107

	Geotextile Sample Specification.....	107
	Gravelless Effluent Dispersal Systems .....	108
	Observation Ports and Vents.....	109
3.7.4	Gravity Trench Distribution System.....	110
3.7.4.1	Gravity trench distribution Description and principles of operation ..	110
3.7.4.2	Gravity trench distribution Design considerations .....	110
	Distribution Box (D-Box).....	110
3.7.4.3	Gravity trench distribution Specifications and Installation considerations .....	111
3.7.4.4	Gravity trench distribution monitoring and maintenance considerations .....	112
3.7.5	Dosed Gravity Distribution System.....	113
3.7.5.1	Dosed Gravity Description and principles of operation .....	113
	Pump to D-Box .....	113
	Serial or Sequential Distribution.....	113
	Pressure Manifold.....	116
3.7.5.2	Dosed Gravity Design, specification and installation considerations.	117
	General.....	117
	Pump to D-Box .....	117
	Serial or Sequential Distribution.....	118
	Pressure Manifold.....	118
3.7.5.3	Dosed Gravity Dosed gravity trench distribution system maintenance and monitoring considerations.....	118
3.7.6	Zones and Distributing Valves.....	119
3.7.6.1	Hydraulic distributing valves, design, specification and installation considerations .....	119
3.7.6.2	Alternating fields, design, specification and installation considerations .....	120
3.7.6.3	Zones and alternating fields, maintenance and monitoring considerations .....	120
3.7.7	Pressurized Effluent Distribution System.....	120
3.7.7.1	Pressurized Distribution Description and principles of operation .....	120
3.7.7.2	Pressurized Distribution Design considerations .....	121
	Sloping Sites .....	123
	Dosing and Distribution Criteria.....	127
	Timed Dosing.....	128
	Distribution .....	128
	Zones.....	129
3.7.7.3	Pump Tank and effluent pump/siphon Design Considerations.....	129
	Pump Tank Sizing.....	130
	Demand Dosing Pump Tank Volumes .....	131
	Timed Dosing Pump Tank Volumes.....	132
	Siphon Systems and Floating Outlet Devices.....	133
3.7.7.4	Pressurized distribution Specifications and Installation considerations .....	134
	Trench Criteria .....	134

Orifice Orientation and Orifice Shields, Cleanouts and Valves .....	134
Cold Weather Criteria .....	135
Pump Tank .....	136
Effluent Pump .....	136
Plumbing Criteria .....	136
Float Switch/Pressure Sensor/Ultrasonic Sensor Criteria .....	137
High Level Alarm .....	137
Low Level Alarm .....	137
Electrical Criteria .....	138
Siphon and Floating Outlet Systems .....	138
Commissioning — Testing .....	138
3.7.7.5 Pressurized distribution Monitoring and Maintenance considerations	139
3.7.8 Rock Pits — Drywells .....	141
3.7.9 Seepage Beds .....	142
3.7.9.1 Seepage Bed Description and Principles of Operation .....	142
3.7.9.2 Seepage Bed Design criteria .....	142
Site Criteria .....	142
Bed Sizing .....	142
Bed Dimensions .....	143
3.7.9.3 Seepage Bed Specifications and Installation Considerations .....	143
Bed Aggregate .....	144
3.7.9.4 Seepage Bed Construction .....	144
3.7.9.5 Seepage Bed Maintenance and Monitoring considerations .....	144
3.7.10 At Grade Bed and Raised Bed Systems .....	144
3.7.10.1 At Grade Bed Performance Standards .....	144
3.7.10.2 At Grade Bed Description and Principles of Operation .....	145
3.7.10.3 At grade bed Design considerations .....	145
Contour Construction and Special Instructions for Concave Slopes .....	146
Bed and Pipe Network .....	146
3.7.10.4 At grade bed Specifications and Installation considerations .....	147
Construction Considerations .....	148
3.7.10.5 At Grade Bed Maintenance and monitoring considerations .....	148
3.7.11 Pressurized Shallow Narrow Dispersal Trenches (PSND) .....	148
3.7.11.1 PSND Performance Standard .....	148
3.7.11.2 PSND Description and Principles of operation .....	149
3.7.11.3 PSND Design considerations .....	151
3.7.11.4 PSND Specification and Installation considerations .....	152
3.7.11.5 PSND Maintenance and monitoring considerations .....	153
3.7.12 Subsurface Drip Dispersal (SDD) .....	153
Moisture Monitoring .....	154
Special Case Vertical Separation .....	155
3.7.13 Site Drainage .....	155
3.7.13.1 Site Drainage Performance Standards .....	155
3.7.13.2 Site Drainage Description and Principles of Operation .....	156
3.7.13.3 Site Drainage Design Considerations .....	157
3.7.13.4 Site Drainage Specifications and Installation considerations .....	158

3.7.13.5	Site Drainage Maintenance and Monitoring considerations .....	158
3.7.14	SWIS on Sloping Sites.....	159
3.7.14.1	Sloping Sites Design considerations.....	159
3.7.14.2	Sloping Sites Specifications and Installation considerations.....	160
<b>3.8</b>	<b>Media Filters with Integrated SWIS: (Including Sand Mounds and Sand-lined Trenches) .....</b>	<b>160</b>
3.8.1.1	Sand Mounds and Sand-lined Trenches Performance Standards .....	160
3.8.1.2	Sand Mounds and Sand-lined Trenches Description and Principles of Operation.....	161
3.8.1.3	Sand Mounds and Sand-lined Trenches Design Considerations .....	164
General	.....	164
Steps of Design Process — Sand Mounds.....		164
Dosing and Distribution.....		167
Steps of Design Process — Sand-lined Trenches.....		168
Contour Construction and Special Instructions for Systems on Concave Slopes .....		169
3.8.1.4	Sand Mounds and Sand-lined Trenches Specifications and Installation Considerations.....	170
General	.....	170
Preparation of Basal Area .....		170
Aggregate.....		171
Mound Sand.....		171
Cover Soil .....		172
Geotextile or Filter.....		172
Uniform Density for Sand Media .....		172
Observation Ports.....		173
Considerations Particular to Above Ground Sand-lined Trenches .....		173
3.8.1.5	Sand Mound and Sand-lined Trenches Maintenance and Monitoring Considerations.....	174
<b>3.9</b>	<b>Evapotranspiration/Absorption (ETA) and Evapotranspiration (ET) Beds ...</b>	<b>174</b>
3.9.1.1	ETA and ET Beds Performance Standards.....	174
3.9.1.2	ETA and ET Beds Description and Principles of Operation .....	175
3.9.1.3	ETA and ET Beds Design and Specification/Installation Considerations .....	176
3.9.1.4	ETA and ET Beds Maintenance and Monitoring Considerations .....	178
<b>3.10</b>	<b>Lagoons .....</b>	<b>178</b>
3.10.1.1	Lagoon Performance Standards .....	178
3.10.1.2	Lagoon Description and Principles of Operation.....	179
3.10.1.3	Lagoon Design Considerations .....	179
Siting Criteria.....		179
General Design.....		180
Gravity Flow Discharge.....		180
Pumped Discharge .....		181
Lagoon Sizing .....		182
Rectangular Lagoons, Wetter Northern Interior BC.....		183
Rectangular Lagoons — Drier Northern Interior BC .....		183

Circular Lagoons, Northern B.C.....	185
3.10.1.4 Lagoon Specifications and Installation Considerations.....	186
Fencing.....	188
3.10.1.5 Lagoon Maintenance and Monitoring Considerations.....	188

## List of Appendices

Appendix A	Glossary of Terms
Appendix B	<i>Sewerage System Regulation, Health Act</i>
Appendix C	Design Inputs Worksheet
Appendix D	Mass Loading: Flow Reduction Devices
Appendix E	Recommendation for Field Tests of Soil Permeability
Appendix F	Performance at Boundaries, Increases to Vertical Separation
Appendix G	Design HLR
Appendix H	Sand Mound Systems
Appendix I	Expanding Clay Soils
Appendix J	Source Control Policy from BCOSSA Maintenance Plan Template
Appendix K	Sodium, Salinity and Water Softeners
Appendix L	Terminology for System Operation and Malfunction
Appendix M	Piping Materials
Appendix N	Surge Flows for Fixtures and Trap Sizes
Appendix O	Testing Tanks for Water tightness
Appendix P	Pressure Distribution Network Design
Appendix Q	Hydraulic Application Rate, Distribution
Appendix R	Temporary industrial camps
Appendix S	Soil Evaluation Log forms

## List of Tables

Table 2-1	Minimum Daily Design Flow Rates for Residences.....	18
Table 2-2	Per Capita Daily Design Flows.....	19
Table 2-3	Facility Daily Design Flow Rates.....	22
Table 2-4	Minimum Vertical Separation (VS) for Trench, At Grade or Seepage Bed Systems	33
Table 2-5	Minimum Vertical Separation for Sand Mounds, Sand-lined Trenches	34
Table 2-6	Horizontal Setback Distances for Critical Setbacks .....	35
Table 2-7	Horizontal Setback Distances for other setbacks.....	38
Table 2-8	Soil Hydraulic Loading Rates for Residential Strength Wastewater....	41
Table 2-9	Sand Media Loading Rates (for Mound Sand) .....	42
Table 2-10	Mound Sand and C33 Fine Aggregate Sieve Analysis.....	43
Table 2-14	Residential Sewage and Type 1 Effluent Standards .....	54
Table 3-1	Minimum Monitoring Intervals .....	67

Table 3-2	Cleanout Sizing and Spacing .....	82
Table 3-3	Minimum Septic Tank Volume .....	90
Table 3-4	Estimated Septic Tank Pumping Frequencies in Years .....	94
Table 3-5	Geotextile Specification.....	108
Table 3-6	Minimum Dosing Frequency .....	128
Table 3-7	SDD Special Case Reduced Vertical Separation .....	155
Table 3-8	Mound Sand Particle Sizing Criteria .....	172
Table 3-9	Minimum Septic Tank Sizing for Lagoon Systems.....	180
Table 3-10	Rectangular Lagoon Cell Sizing .....	183
Table 3-11	Rectangular Lagoon Cell Sizing .....	184
Table 3-12	Circular Lagoon Cell Sizing Standards.....	185

## List of Figures

Figure 2-1	Vertical Separation between the Infiltrative Surface and the Restrictive Layer.	31
Figure 2-2	Linear Loading Rate on a Slope, Showing Trench Cross Sections .....	46
Figure 2-3	How Effluent Flows Away from a Discharge Area, and How this Affects LLR	47
Figure 3-1	System Selection in Relation to Soil Depth.....	70
Figure 3-2	Diagram: STEP System Schematic Plan and Individual Connection...	77
Figure 3-3	Diagram: Other Collector Systems, Showing Individual Connections	78
Figure 3-4	Compartmentalized Septic Tank.....	84
Figure 3-5	Flow in a Septic Tank. ....	85
Figure 3-6	Septic Tank with Multiple Compartments Provided by Individual Tanks, and Pump Chamber in Third Compartment.....	86
Figure 3-7	A SWIS Trench System, Showing Terminology .....	100
Figure 3-8	Trench Dispersal Layout.....	103
Figure 3-9	Vent and Combination Vent and Observation Port Examples.....	109
Figure 3-10	Gravity Trench Distribution.....	110
Figure 3-11	Distribution Box.....	111
Figure 3-12	Serial System (Top and Side Views) .....	115
Figure 3-13	Sequential (Drop Box) System (Top View).....	116
Figure 3-14	Sequential (Drop Box) System (Side View).....	116
Figure 3-15	Pressure Distribution System.....	121
Figure 3-16	Tee to Tee Manifold, with Check Valves. ....	124
Figure 3-17	Cross Manifold, with Check Valves. ....	125
Figure 3-18	Short Upslope Header Manifold, with Feeder Pipes to Laterals. ....	126
Figure 3-19	Short Downslope Header Manifold, with Check Valves.....	127
Figure 3-20	Pump Tank Nomenclature: Showing Piping Layout Suitable for Areas Where Heavy Frost Is Not Encountered. ....	130
Figure 3-21	Schematic of Demand Dosing Terms .....	132

Figure 3-22	Schematic of Timed Dosing Terms: Showing Example of Tank with Lag Float	133
Figure 3-23	Seepage Bed Pressure Dispersal Typical Cross Section.....	142
Figure 3-24	At Grade Bed Typical Cross Section.....	145
Figure 3-25	Shallow Narrow Drainfield Cross Sections.....	151
Figure 3-26	Use of an Interception Drain.....	156
Figure 3-27	Trench Depth Variance on Sloped Site.....	159
Figure 3-28	Example of a Mound Cross Section Showing Nomenclature.....	161
Figure 3-29	Sand-lined Trench.....	162
Figure 3-30	Sand-lined Trench with High Permeability Soils to Surface, Option 1	162
Figure 3-31	Sand-lined Trench with High Permeability Soils to Surface, Option 2	163
Figure 3-32	Sand-lined Trench to Reach Suitable Soil at Depth.....	163
Figure 3-33	Above Ground Sand-lined Trench.....	164
Figure 3-34	Mound Layout Schematic, Letter Dimensions Are as Used in the Worksheet.	165
Figure 3-35	Horizontal Setbacks are Measured from the Edge of the Minimum Basal Area of the Mound.....	166
Figure 3-36	Calculation of Effective Bed Length on Site with Concave Contour.	169
Figure 3-37	Rectangular Lagoon.....	184
Figure 3-38	Rectangular Lagoon (top view).....	185
Figure 3-39	Circular Lagoon.....	186
Figure 3-40	Circular Lagoon (Top View).....	186

**Source of figures used in the manual**

**199**

# **PART 1: Introduction and Administration**

## ***1.1 Purpose and Content of the Sewerage System Standard Practice Manual***

---

The Sewerage System Standard Practice Manual (SPM) provides a form of standard design, installation, maintenance and supervision practice for sewerage systems. Sewerage systems, other than holding tanks and privies are the subject of this manual.

The manual serves as a guideline for authorized persons seeking to comply with “standard practice” as required under the Health Act’s Sewerage System Regulation (SSR). Sections 8 and 9 of the SSR require authorized persons to certify that certain actions have been done or will be done in accordance with “standard practice”. That term “standard practice” is defined to mean “a method of constructing and maintaining a sewerage system that will ensure that the sewerage system does not cause, or contribute to, a health hazard”. Sections 8(3) and 9(2) also specifically provide that an authorized person may have regard to the “Sewerage System Standard Practice Manual” as amended from time to time in order to determine whether they are in compliance with standard practice.

Consequently, the manual constitutes one form of “standard practice”, however there will be other forms of standard practice that can be undertaken to meet the requirements of the SSR. The manual makes strong recommendations as to when deviation from the manual in favour of an alternative form of standard practice is appropriate (see 1.1.2, 1.1.4).

It should also be noted that accrediting bodies may, if they have authority under their governing statutes, choose to make certain aspects of this manual legally binding on their members, and to restrict their ability to depart from certain aspects of it. ASTTBC has mandated through policy that its registered members (i.e., registered practitioners) use and follow the SPM.

No standards or guidelines of the SPM are intended to conflict with any Act or Regulation, and in all cases where a conflict arises, the Act or Regulations supersede the SPM.

### **1.1.1 Overview of Sewerage System Regulation**

The Sewerage System Regulation falls under the *Health Act (See Appendix B)*, and applies to the construction, and maintenance of:

- a holding tank;
- a sewerage system that serves a single family residence or a duplex;

- a sewerage system or combination of sewerage systems with a combined design daily domestic sewage flow of less than 22,700 litres that serves structures on a single parcel; and,
- combination of sewerage systems with a combined design daily domestic sewage flow of less than 22,700 litres that serves structures on strata lots or on a shared interest.

The Sewerage System Regulation applies to domestic sewage, which includes:

- human excreta; and,
- waterborne waste from the preparation and consumption of food and drink, dishwashing, bathing, showering, and general household cleaning and laundry, except waterborne waste from a self-service Laundromat.

The Sewerage System Regulation prohibits an owner of a sewerage system from causing or contributing to a “health hazard”. A “health hazard” is defined as the discharge of domestic sewage or effluent into a source of drinking water, surface waters, tidal water, a sewerage system that is not capable of containing or treating domestic sewage, or onto land. The provisions of the Municipal Sewage Regulation under the *Waste Management Act* govern these types of discharges.

The Sewerage System Regulation prohibits a person from constructing or maintaining a sewerage system that uses a Type 1 or 2 treatment method unless qualified as a “authorized person” (AP) (*see Section 6(1)*). An authorized person is defined as a “registered practitioner” or “professional”. The Sewerage System Regulation also prohibits a person from constructing or maintaining a sewerage system that uses a Type 3 treatment method or is designed for an estimated daily domestic sewage flow of more than 9,100 litres, unless supervised by a “Professional” (*see Section 6(3)*).

After construction of the system has been completed, the Sewerage System Regulation requires “Authorized Persons” (“Professionals” or “Registered Practitioners” as defined in the Regulation) to file with the Health Authority (HA) a signed letter certifying the system plans and specifications are consistent with “standard practice.” The “Authorized Person” (AP) is also required to provide the owner with a maintenance plan that is consistent with standard practice.

Sections 8(3) and 9(2) specifically provide that an authorized person may *have regard* to the “*Sewerage System Standard Practice Manual*” as amended from time to time in order to determine whether they are in compliance with standard practice.

Authorized Persons must also note that construction, operation and maintenance of sewerage systems are regulated by statutes and regulations other than the *Health Act* and the Sewerage System Regulation. No standards or guidelines of the SPM are intended to conflict with any Act or Regulation, and in all cases where a conflict arises, the Act or Regulations supersede the SPM.

Note: Neither the Sewerage System Regulation nor the Standard Practice Manual provides standards related to approval for the subdivision of lands. Subdivisions are legislated by the Subdivision Regulation under the *Local Services Act*, unless a local government enacts a by-law that governs land use within its jurisdiction. Approving Officers (who compile information from various levels of government including provincial ministries, regional districts and federal agencies) administer subdivisions. As part of this process and where sewers do not serve land, provincial government Approving Officers will refer subdivision applications to the local Health Authority (HA). HA's are requested to provide comment on any such proposals. HA's typically only support Type 1 systems be used in such cases. Although the comments of HAs are not legally binding on Approving Officers, they are given considerable weight and are often followed.

## 1.1.2 Content — SPM STANDARDS

The content of this manual covers all systems dealt with in the definition of “sewerage system” under the SSR but excludes holding tanks. Privies are not regulated by the Sewerage System Regulation.

This manual sets out standards for sewerage systems handling less than 22,700 litres per day of domestic sewage, including:

- effluent qualities produced through the use of Type 1, 2 or 3 treatment methods as defined in the regulation (also known as Pre-treatment);
- Subsurface Wastewater Infiltration Systems (SWIS), including those combined with the use of added non-natural soil media, such as sand mounds and sand-lined trenches; and,
- B.C. zero discharge sewage lagoons.

The manual is not intended as a design specification nor is it an instruction manual for untrained persons.

### 1.2.1.1 STANDARDS

The Sewerage System Regulation and this manual are based on performance rather than prescription of techniques. Also, the B.C. industry is moving towards a performance-based, industry focussed system (with industry assuming accountability).

This manual supports this process by providing critical standards in Part 2, and significant standards and guidelines in Part 3 of the SPM.

#### ***Part 2 critical standards***

Standards in Part 2 of the SPM are deemed “critical standards” as they are strong indicators of

- whether an AP will be meeting “standard practice” as is required by the SSR and/or
- whether the system as designed, installed and operated will not cause or contribute to the creation of a health hazard

It is **highly recommended** that these critical standards be followed by all APs (professionals and registered practitioners) and that **any deviation** from **any** critical standard:

- be made **only by a professional, or under the supervision of a professional**;
- be supported by reference to authoritative, peer-reviewed sources relevant to the climate and soil of the areas in which the system will be used; and
- be made only with the AP's assurance that the resulting system will function within the environment at an equal or better performance level as would have been provided by the SPM critical standard. This assurance should include monitoring of process and environmental performance.

It is also recommended that wherever explicitly identified in Part 2 of the SPM, deviation from critical standards should only be made by an AP that meets specific qualifications (e.g., groundwater hydrologist).

### **Part 3 significant standards and guidelines**

Part 3 of the SPM provides “significant standards and guidelines” which include important standards and guidelines for onsite technologies and offer best practices for the design, filing, construction and maintenance of sewerage systems appropriate for use in B.C . These significant standards are good indicators of

- whether an AP will be meeting “standard practice” as is required by the SSR and/or
- whether the system as designed, installed and operated will not cause or contribute to the creation of a health hazard

It is **recommended** that these significant standards and guidelines be followed by all APs (professionals and registered practitioners) and that **any deviation** from **any** of these significant standards:

- be supported by reference to authoritative sources relevant to the climate and soil of the areas in which the system will be used; and
- be made only with the AP's assurance that the resulting system will function within the environment at an equal or better performance level as would have been provided by the SPM standard or guideline.

It is also recommended that wherever **explicitly identified in Part 3** of the SPM, deviation from the Part 3 significant standards or guidelines should only be made by an AP that meets specific qualifications (e.g., **is a professional**, groundwater hydrologist, etc.).

#### **1.2.1.2 LINKED STANDARDS**

In certain cases a standard is made up of linked steps that should be followed in order to properly meet the overall recommended standard.

For example, when the SPM states that the HLR tables “must” or “should” be used with the SPM Daily Design Flows, it is making it clear that if these steps are not linked malfunction of the system may result. Therefore where a standard is identified as linked in the manual, it is *highly recommended* that all standards are followed.

Part 2 critical standards are considered to be linked standards. In addition, where a “critical standard” in Part 2 is comprised of linked steps and includes linkage to the “significant standards” of Part 3 of the manual, the manual in Part 2 will indicate this.

The application of Part 3 significant standards are linked to use of the Part 2 critical standards as provided in this manual and discussed above.

Also, in Part 3 the significant standards provided for each technology are considered to be linked. Where the standard for a technology is linked to that for another technology, the manual in Part 3 will indicate this.

### **1.1.3 Organization of the manual**

The Standard Practice Manual is organized into three parts:

- Part 1 contains the introduction, information on roles and responsibilities, and administrative information.
- Part 2 provides key information on practice and contains “critical standards” for onsite systems.
- Part 3 presents “significant standards” which serve as a “toolbox” of technologies for Authorized Persons and offer best practices for the design, filing, construction and maintenance of sewerage systems appropriate for use in B.C.

Appendices containing further supporting information and worksheets supplement the three parts of this manual.

### **1.1.4 Application of Standard Practice by Authorized Persons**

The Sewerage System Regulation defines “**standard practice**” as a “method of constructing and maintaining a sewerage system that will ensure that the sewerage system does not cause, or contribute to, a health hazard”.

Section 8(3) and 9(2) of the SSR contemplates that authorized persons may have regard to this manual in order to determine what is or is not standard practice in particular cases. Consequently, the manual constitutes one form of “standard practice”. Although the SPM is not legally binding, it should be considered by all authorized persons, and departures from the standards and guidelines set out in the manual should only be made if specifically contemplated by the manual itself, or where other compelling reasons exist based on other methods of standard practice. The SPM makes recommendations as to

when deviation from the manual in favour of an alternative form of standard practice is appropriate.

Some departures from the manual may be more consequential than others, and it may not be appropriate for all types of authorized persons to make all types of decisions concerning such departures. Rather, there will be certain aspects of standard practice that are sufficiently important, or which require certain expertise, such that they should only be undertaken by a professional, or under the supervision of a professional. These standards are explicitly referred to throughout the SPM.

In order to provide further guidance as to what the term “standard practice” means in practical application, the SSLC considers “standard practice” to mean:

a current publication by an onsite wastewater recognized authority that provides a detailed description of a method or technique and/or treatment objective to be applied to the construction and maintenance of sewerage systems for site assessment, soil evaluation, installation, or maintenance that when applied does not create or contribute to a health hazard or environmental risk.

The points outlined above have helped establish the recommended departure criteria from this form of standard practice under the SPM. See section 1.1.2.

It should also be noted that section 6 of the SSR makes it a legal requirement that only professionals or persons supervised by professionals may construct or maintain a sewerage system that uses a treatment method classified as Type 3 or is designed from an estimated minimum daily domestic sewage flow of more than 9100 litres. Registered practitioners are limited by the SSR to construction and maintenance of Type 1 and 2 systems, unless supervised by a professional.

Authorized persons should also check with their accrediting body to determine whether sections of this manual have deemed mandatory by the governing body for their membership. For example, ASTTBC has mandated through policy that its registered members (i.e., registered practitioners) use and follow the recommendations of the SPM. All APs are bound by their accrediting body’s code of ethics (e.g., ASTTBC for Registered Practitioners or APEG for Professional Engineers) to only practice in areas that they are qualified for by means of education and experience.

## ***1.2 Administrative***

---

### **1.2.1 Administrative Process**

Before construction, alteration, or repair to a sewerage system may begin, Authorized Persons will file the following information with the Health Authority:

- the property’s legal description;
- the property owner’s name and contact information;

- the site and soil investigation report;
- the sewerage system design and layout; and,
- the plans and specifications of the sewerage system, including the rationale for the design.

Plans and specifications and other sewerage system information will have the Authorized Person's seal affixed.

The Authorized Person will submit all information in a format acceptable to the Health Authority. A standard form is available from local Health Authorities.

Within thirty days of completing the installation of the sewerage system, the Authorized Person will:

- file a letter certifying compliance with the Sewerage System Regulation to the Health Authority; and,
- provide the owner and Health Authority with the sewerage system operations, specifications, commissioning details, and maintenance plan that meet the recommended standards of Part 3 of this manual.

Under section 9(3) of the SSR, if the AP does not file a letter of certification within one year of filing the initial information about the sewerage system, then the filing becomes void and the Authorized Person may not start or continue construction of the sewerage system until a new filing is made.

## **1.2.2 Circumstances Where HA Could Return AP Filing**

A file submission could be returned to the AP by a Health Authority when:

- information is determined to be false and/or misleading;
- information is missing and the AP needs to complete the submission, or
- changes to the application are sufficient to warrant cancellation.

When a filing is returned, the Health Authority could notify any additional authorities that may have jurisdiction over the affected property.

In addition, APs must be aware that it is an offence to knowingly make a false or misleading statement in providing filing information under section 9 or during an inspection under section 11(a) of the *Sewerage System Regulation*.

## **1.2.3 Filing Notification Referrals**

The Health Authority could notify the local building inspection department or local government authority about the filed sewerage system, and vice versa.

Notification may not be needed when:

- sewerage system repairs or alterations of an existing developed property will not affect the building envelope or change the physical placement of the system.

#### **1.2.4 Privacy**

The *Freedom of Information and Protection of Privacy Act* will govern the information provided, as part of the filing process, and will be released in accordance with the provision of the *Act*.

#### **1.2.5 Other Administrative Jurisdictions**

It is the responsibility of the Authorized Person to ensure that all local zoning and/or by-laws are complied with.

#### **1.2.6 Restrictive Covenants**

The Authorized Person(s) will need to ensure that the filing under *Section 8* of the Sewerage System Regulation includes a copy of, and complies with, any covenants attached to the property title.

#### **1.2.7 Use of Adjacent Property**

The use of a sewerage system on adjacent property could be constructed on adjacent property if there is no suitable area for construction or repair on the primary property, subject to the following principles:

- it must meet all conditions of the Regulation and has the approval of the adjacent landowner; and,
- it should only be undertaken where the person installing the system has obtained legal advice concerning the need to protect the system by easements and/ or covenants.
  - Although this is not legally required in order to install the system if the owner's consent is otherwise obtained, considerable legal problems could develop if the system is not protected by easements and / or covenants and it would be unwise for an authorized person to participate in the installation of such a system in the absence of such legal issues being adequately addressed

A sewerage system could be connected to another sewerage system upon an adjacent property when:

- there is no suitable area for construction or repair on the primary property and there is the approval of the adjacent landowner;
- the sewerage system on the adjacent lot can adequately accept the additional load; and,

- the sewerage system on the adjacent lot will not create a problem or cause a health risk.
- the person installing the system has obtained legal advice concerning the need to protect the system by easements and/ or covenants.

### **1.2.8 Easements and Covenants**

The use of an adjacent property for the installation of a sewerage system:

- should be registered with the local Health Authority; and,
- should be secured by an easement protected by covenant that is prepared by a qualified lawyer.

Any changes to registered covenant(s) will require agreement by the Health Authority.

### **1.2.9 Repairs and Replacements, new uses of systems**

If a sewerage system was constructed prior to the SSR coming into force on May 31, 2005 and is in need of repair or replacement it is recommended that work be done in accordance with the SPM. If work cannot be done in accordance with the SPM, then the Authorized Person could deviate from the manual. A departure from the SPM is permitted only to the degree necessary to repair or replace the system in a manner that will not create a health hazard. Deviation from a critical minimum horizontal separation of Part 2 of the SPM should only be made by a professional.

In emergency situations, an Authorized Person may:

- carry out the work necessary to eliminate a health hazard arising from systems suffering from performance malfunction; and,
- maintain the function of that system until permanent repairs or replacements can be carried out in accordance with the *SSR* and the Standard Practice Manual.

Existing systems, subject to repair or replacement, should be brought into compliance with the Sewerage System Standard Practice Manual where practicable.

All regulatory filing provisions of section 8 and 9 of SSR apply where a significant alteration or repair is being made to the sewerage system.

#### **1.9.2.1 COMPONENT REPAIR OR REPLACEMENT**

Authorized Persons are not required to submit a “filing” document for the repair or replacement of any minor sewerage system parts such as the:

- liquid level float switch;
- pump — of exact same brand and model or equal;
- level of d-box adjustment;

- d-box or other distribution device replacement with same or equivalent unit;
- tank inlet or outlet fittings;
- septic tank effluent filters' cleaning or replacement;
- installation of an effluent filter and related equipment;
- dispersal field lines' flushing or vacuuming; or,
- dispersal field lines or pipe section replacement — when the pipe is broken or damaged to the point where it is not working or likely to work.

#### 1.9.2.2 SYSTEM REPAIR OR REPLACEMENT

Authorized Persons must prepare and submit a filing document to the Health Authority for the repair or replacement of any major system item, such as adding to or replacing septic/pump tanks, dispersal systems (trenches, beds, mounds), and lagoon cells per section 8 and 9 of the SSR.

Where the existing system has malfunctioned, due to increases in daily sewage flow rates, then repair or replacement should be made to accommodate the increase in daily sewage flow.

All regulatory filing provisions apply. This includes plans, specifications and a site evaluation.

#### 1.9.2.3 NEW USES OF AN EXISTING SYSTEM

Where a new use will be made of an existing system previously permitted under the 1985 S.D.R. (Sewage Disposal Regulation) (for example, a house being built to replace a temporary or seasonal dwelling), a question may arise as to the suitability of the system for the new use.

At a minimum in these cases, the Authorized Person should document the system with an as-built or inspection plan and should make a site evaluation including a description of the soil profile and depth of the SHWT or restrictive layer (*see Section 2.3.2*) as well as making a documented inspection of the system for function.

As a guideline for systems up to 10 years old, a permitted system which met standards of the day for the new Daily Design Flow and use and is functioning to current performance standards could be said to be suitable. In other cases a site and project specific evaluation should be made, and this could require that the system be upgraded to current standards as a new filing; in this case all regulatory filing provisions apply including plans, specifications and a site evaluation with report.

### **1.2.10 Seasonal Dwellings — No Hydro Connection, Isolated Areas**

Seasonal use systems should be installed in compliance with the Sewerage System Standard Practice Manual.

If it is not possible to apply the standard techniques described in Part 3 of the Standard Practice Manual because of site constraints, seasonal use or limited water use, then the Authorized Person could deviate from the manual. However it is recommended that the departure from the manual be restricted to construction methods (techniques) and only to the degree necessary to repair or replace the system in a manner that will not cause or contribute to a health hazard (as prohibited by the SSR).

Please note that Type 2 or Type 3 systems should not normally be used for seasonal dwellings because they typically depend on electricity for their electrical components, and may rely on biological processes that cannot be sustained under seasonal conditions. If used in these cases, the system design and operation should address the seasonality of use and assure maintenance of the specified effluent quality.

### **1.2.11 Multiple Homes on Same Property**

When two homes occupy one property or a system serves two sources of domestic sewage on one property, the Authorized Person must make sure that the single or combined sewerage system complies with the Sewerage System Regulation and local land use by-laws. AP's should also ensure that such arrangements comply with the Sewerage System Standard Practice Manual.

Note that any number of single-family dwellings or duplex units serviced by and connected to their own individual systems on an individual one-to-one basis are covered under the *SSR* regardless of the number of such individual systems on the one lot.

## ***1.3 Roles and Responsibilities***

---

### **1.3.1 Health Authority**

Health Authorities have statutory authority under the *Health Authorities Act* to:

- administer and enforce the Sewerage System Regulation;
- carry out legal remedies such as orders or tickets;
- accept documents for filing and certification of systems, providing record of filing and letters of acknowledgement of certification;
- ensure documents meet the Sewerage System Regulation;
- ensure that only Authorized Persons plan, construct or maintain installed sewerage systems; and,

- inspect and take corrective action to alleviate health hazards related to an onsite wastewater system.

### 1.3.2 Authorized Person

The SSR defines an “authorized person” as a registered practitioner or a professional.

The SSR defines a “professional” as a person who meets the requirements of section 7(3). Section 7(3) requires that in order to be qualified as a professional a person must have specific training and belong to a specific type of professional association as a fully trained and practicing member.

The SSR defines a “registered practitioner” as a person who meets the requirements of section 7(1) or 7(2). These sections require that in order to be qualified as a registered practitioner, a person

- must meet specific educational requirements or be able to demonstrate to BCCOSA that the person is competent to construct and maintain a type 1 or 2 sewerage system and
- hold a registration certificate from ASTTBC. In practice, ASTTBC refers to a “registered practitioner” as a Registered Onsite Wastewater Practitioner (ROWP).

Section 6 of the SSR requires that only professionals or persons supervised by professionals may construct or maintain a sewerage system that uses a treatment method classified as Type 3 or is designed from an estimated minimum daily domestic sewage flow of more than 9100 litres. Registered practitioners are limited by the SSR to construction and maintenance of Type 1 and 2 systems.

It is further recommended in Part 2 of the SPM that only professionals, or persons under the supervision of a professional be able to depart from any critical standard listed in that Part. It is also recommended that *wherever explicitly identified* in Parts 2 and 3 of the SPM, deviation from the standards or guidelines should only be made by an AP that meets specific qualifications (e.g., *is a professional*, groundwater hydrologist, etc.). In addition, some forms of standard practice discussed in the manual should only be undertaken by a professional or an authorized person with specialized training (e.g., *is a professional*, groundwater hydrologist, etc.) and expertise in terms of system design, based upon particular use, soil and site characteristics.

ASTTBC has mandated through policy that its registered members (i.e., registered practitioners) use and follow the recommendations set out in the SPM. In addition, all AP's are bound by their code of ethics to only practice in areas in which they are qualified for by means of education and/or experience.

Under the SRR, authorized persons are responsible for:

- providing a letter of certification to the Health Authority (when the sewerage system is completed) which indicates that the sewerage system was installed in accordance with filed plans and standard practices;
- providing the homeowner and the Health Authority with the sewerage system maintenance plan (a maintenance plan is a set of instructions for maintaining a sewerage system that, if followed, will ensure the system does not cause or contribute to a health hazard).

According to the SPM an Authorized Person should:

- be completely knowledgeable of all the components of a sewerage system and thoroughly understand how they integrate and should perform;
- be familiar with the practice of developing plans, details, specifications, instructions, or inspections in the analysis of soil morphology, hydrology, geology, site layout, collection, conveyance, dispersal, sewage treatment technologies and their classifications;
- have a comprehensive knowledge of how the sewerage system that is being designed works, and is able to evaluate and repair systems;
- be responsible for correctly identifying site conditions and assigning wastewater loading rates;
- be capable of preparing a comprehensive written site/soil evaluation report;
- use the site/soil evaluation report to plan the sewerage system, including the placement of components, tank sizing, effluent quality classification, treatment process, sub-surface effluent dispersal method, sub-surface effluent dispersal sizing, and reserve area standards;
- be responsible for consultation with the property owner, applying good judgment, and preparing a plan that addresses the limitations of the property and is in compliance with the Sewerage System Regulation and the Standard Practice Manual;
- ensure that sewerage systems are planned, installed and maintained ethically, competently and with due diligence;
- present documentation in a clear format, and files plans and specifications of the sewerage system in a manner acceptable to the Health Authority;
- ensure plans and specifications are consistent with the Sewerage System Standard Practice Manual and standard practice;
- start and test the sewerage system to verify that all equipment is functioning as intended.

Refer to Part 3, Section 3.3 for recommended standards and guidelines for documentation and practice for APs.

### **1.3.3 Sewerage System Owner**

Section 10 of the SSR requires that an owner of a sewerage system

- ensure that the system is maintained in accordance with the maintenance plan; and
- keeps a record of all maintenance service performed on the system;

Under the SSR, the system must be maintained by an AP, so the owner commits an offence under the SSR if they maintain it without proper qualifications. The owner must also ensure that they are in compliance with all other requirements under the SSR and with local government by-laws.

Sewerage system owners should also ensure that the system is operated correctly (in accordance with the maintenance plan).

## PART 2 Critical Standards

### ***2.1 Critical Standards***

---

#### **2.1.1 Base Performance Standards**

Performance standards for onsite sewage systems exist, at the most fundamental level, to ensure that the system as designed, installed and operated does not contribute to the creation of a health hazard.

The Sewerage System Regulation describes discharge of sewage or effluent to the land surface or water (surface, tidal or drinking water) as a health hazard. Effluent may not be permitted to surface or to contaminate water bodies or drinking water sources.

#### **2.1.2 Part 2 — Critical Standards**

To support these base performance standards, Part 2 of the Standard Practice Manual (SPM) describes critical standards for onsite sewage systems.

Standards in Part 2 of the SPM are deemed “critical standards” as they are strong indicators of

- whether an AP will be meeting “standard practice” as is required by the SSR and/or
- whether the system as designed, installed and operated will not cause or contribute to the creation of a health hazard

It is ***highly recommended*** that these critical standards be followed by all APs (professionals and registered practitioners) and that ***any deviation*** from ***any*** critical standard:

- be made ***only by a professional, or under the supervision of a professional;***
- be supported by reference to authoritative, peer-reviewed sources relevant to the climate and soil of the areas in which the system will be used; and
- be made only with the AP’s assurance that the resulting system will function within the environment at an equal or better performance level as would have been provided by the SPM critical standard. This assurance should include monitoring of process and environmental performance.

It is also recommended that wherever explicitly identified in Part 2 of the SPM, deviation from critical standards should only be made by an AP that meets specific qualifications (e.g., groundwater hydrologist, etc.).

In addition, it is recommended that some critical standards within the SPM be achieved by professionals or other AP's with specialized training only or under the supervision of these persons, as opposed to a practitioner solely. Where this is the case, this is indicated in the manual.

Critical standards aid in the correct and safe installation of an onsite system. To avoid a health hazard, environmental impact or a system malfunction, it is critically important that the system's design, installation, and operation follow these standards.

The critical standards presented in this manual are supported by peer reviewed research and represent standard practice. When developing standards, the B.C. industry considered practicality and cost.

It should also be noted that section 6 of the SSR makes it a legal requirement that only professionals or persons supervised by professionals may construct or maintain a sewerage system that uses a treatment method classified as Type 3 or is designed from an estimated minimum daily domestic sewage flow of more than 9100 litres. Registered practitioners are limited by the SSR to construction and maintenance of Type 1 and 2 systems, unless supervised by a professional.

Authorized persons should also check with their accrediting body to determine whether sections of this manual have deemed mandatory by the governing body for their membership. For example, ASTTBC has mandated through policy that its registered members (i.e., registered practitioners) use and follow the recommendations of the SPM. In addition, all AP's are bound by their code of ethics to only practice in areas in which they are qualified for by means of education and/or experience.

#### **2.1.2.1 LINKED STANDARDS**

In certain cases a standard is made up of linked steps that should be followed in order to properly meet the overall recommended standard.

For example, when the SPM states that the HLR tables "must" or "should" be used with the SPM Daily Design Flows, it is making it clear that if these steps are not linked malfunction of the system may result.

Part 2 critical standards are considered to be linked standards. In addition, where a "critical standard" in Part 2 is comprised of linked steps and includes linkage to the "significant standards" of Part 3 of the manual the manual in Part 2 will indicate this.

### **2.1.3 Organization and Use of Part 2**

Part 2 of the SPM is organized to follow the process of a typical onsite design. This same sequence is followed in the "Design Inputs Worksheet," provided in Appendix C.

This sequence is split into two main parts:

- Determining use and Daily Design Flow for the site; and,
- Determining treatment and discharge needs.

To support this process, Part 2 provides tables of site constraints and of limitations for use of certain systems. These tables should be used when selecting a system for a site. Part 3 also provides recommended solutions to common site constraints. (*See Section 3.4.*)

Part 2 finishes with standards for residential sewage and treatment methods.

The layout of Part 2 is:

- Daily Design Flow Selection (*Section 2.2*)
- Soil and Site Investigation (*Section 2.3.2*)
- Vertical and Horizontal Separation Standards (*Section 2.3.3*)
- Hydraulic Loading Rate (HLR) Standards (*Section 2.3.4*)
- Linear Loading Rate (LLR) Standards (*Section 2.3.5*)
- Site Capability and System Selection (*Section 2.3.6*)
- Residential Sewage and Treatment Standards (*Section 2.4*)

## ***2.2 Daily Design Flow Selection (DDF)***

---

The owner is responsible for the operation of the sewerage system. Owners should disclose all present and future system uses and all discharge sources. The owner should be made aware that the system:

- should never operate beyond its design limit;
- should never receive flows from other sources; and,
- should never receive flows in excess of declared flows.

Wastewater Daily Design Flow does not refer to the system's average flow. Daily Design Flow (DDF) considers mass loading to a dispersal field, and it includes a factor for peak flow. Both factors are based on influent sewage flows and quality meeting residential standards (*See Table 2-14 for Residential Sewage and Type 1 Effluent Standards.*)

The soil loading rates in the SPM are based on the Daily Design Flow defined in Section 2.4. In all cases system flows should be monitored (*See Section 2.4*).

NOTE: Daily Design Flow is the (peak) flow to be used as "design daily domestic sewage flow" or "estimated daily sewage flow" or "estimated minimum daily domestic sewage flow" as referenced in the *Sewerage System Regulation*.

### **2.2.1 Daily Design Flow Rates for Residences**

A residence's Daily Design Flow is estimated by using one of two methods: The Standard Method or the Secondary Method. Regardless of which method is used, Daily

Design Flow should always be clearly stated in the Filing documentation, and system owners:

- should make a declaration of building size, number of bedrooms, use, occupancy, size of living space;
- should be made aware of the system’s design flow and allowable average flow;
- should be made aware of what can be put into a residential onsite system;
- should sign a Written Acknowledgement that they will undertake to use the system within these allowable flows; and,
- should observe the source control policy in the system maintenance plan.

The Filing documentation along with the owner’s Written Acknowledgement is then included with the Letter of Certification and filed with the Health Authority (HA). *For more information on Health Authorities, see Section 1.3.1).*

### 2.2.1.1 STANDARD METHOD

To select the minimum Daily Design Flow for a residential sewerage system, use Table 2-1. To choose the correct flows, consider the residence’s current use and any additional or potential future use. The Authorized Person (AP) should consider:

- the number of bedrooms in the home; and,
- the total floor area of the home.

Including the residence’s total floor area when selecting Daily Design Flows helps the AP address the higher use associated with current trends for building larger homes. By including the total floor area, the potential for future use is also taken into consideration.

NOTE: See footnote to Table 2-2 for information on luxury homes.

**Table 2-1 Minimum Daily Design Flow Rates for Residences**

Residence Size	Minimum Design Flow	
	LITRES	GALLONS
1 and 2 bedroom unit up to 150 m <sup>2</sup> 1,600 ft <sup>2</sup>	1,136	250
3 bedroom unit up to 175 m <sup>2</sup> 1,885 ft <sup>2</sup>	1,363	300
4 bedroom unit up to 235 m <sup>2</sup> 2,530 ft <sup>2</sup>	1,700	375
5 bedroom unit up to 295 m <sup>2</sup> 3,175 ft <sup>2</sup>	2,045	450
6 bedroom unit up to 355 m <sup>2</sup> 3,820 ft <sup>2</sup>	2,500	550
For every additional m <sup>2</sup> add	4.5	1

**NOTES:**

Daily Design Flows include a combined peaking factor of 1.5 – 2 and represent normal or average residential use.

Total floor area to be used is that for living space, this is: The total net floor area of a building less the floor area of a garage, breezeway, carport, crawl space or decks exterior to the building's foundation walls.

**2.2.1.2 SECONDARY METHOD (SPECIAL CASES)**

Where the flow calculated using Table 2-1 exceeds 150% of the minimum Daily Design Flow (based on number of bedrooms alone) *AND* a residence's use is not typical (for example, large areas of the home are not occupied), then the secondary method could be used. This method is also of use where occupancy is higher than normal.

Under this method should the AP consider a minimum number of occupants per bedroom. Where occupant load is projected to be higher, then use the larger number.

**Table 2-2 Per Capita Daily Design Flows**

Use	Per person flow (L)
Single family dwelling	470
Multi-family (apartment, house and cabin, townhouse)	380
Luxury homes	1,140
Summer cottage	300
Mobile home	300
NUMBER OF BEDROOMS	MINIMUM NUMBER OF OCCUPANTS
1	2
2	3
3	3.5
4	4
5	5
6	6

**NOTES:**

Figures are based on research data including Laak, R, 1986. Wastewater engineering design for unsewered areas: Tchobanoglous, G, Burton, F, 1991. Wastewater Engineering Treatment, Disposal, and Reuse: USEPA, 2002. USEPA Onsite Wastewater Treatment Systems Manual.

Design flows include a combined peaking factor of 2 and represent normal or average residential use.

Research data indicates that the average residence has 2.7 people living in the household; average occupancy per bedroom is 1 to 1.5 persons.

Luxury home per occupant average flows are expected to be higher, they are often characterized by:

- Large size with large rooms
- High quality, high cost materials
- Extra water use appliances
- Domestic service workers
- More frequent and larger entertainment, more guest use.

Luxury homes could also be defined as homes that have a value greater than five times the average home value in the area.

Luxury home figures could also be used for homes larger than 3,500 ft<sup>2</sup> where the AP considers flows will be representative of luxury home use (Ref. Kansas State and others).

Daily Design Flow should be used even though flow equalization is employed.

Example calculations:

1. Occupancy of 8 persons (average), standard single family dwelling, 5 bedrooms. Minimum number of occupants for 5 bedrooms is 5, so base calculations on 8 people.

$$\text{Estimate of Daily Design Flow} = 8 \times 470 = 3,760 \text{ L/day}$$

2. Occupancy of 3 persons (average), standard single family dwelling, 5 bedrooms. Minimum number of occupants for 5 bedrooms is 5, so base calculations on 5 people.

$$\text{Estimate of Daily Design Flow} = 5 \times 470 = 2,350 \text{ L/day}$$

### 2.2.1.3 MINIMUM DAILY DESIGN FLOW RATES FOR FACILITIES

Typical unit Daily Design Flows for many types of facilities and commercial enterprises are shown in Table 2-3. When designing systems for facilities, it is important to note that:

- flow measurements by metre, pump cycles, and/or duration should be considered;
- the safety factor for commercial flows is higher than residential flows; and,
- mass loading is considered where effluent does not meet residential sewage standards.

Daily Design Flow and type/quality of influent should be clearly stated on the filing document.

System owners should be made aware of:

- these design flows;
- the standards for influent quality; and,
- the allowable average flows to the system.

Owners should sign a letter indicating they understand the system's restrictions and use and will observe conditions outlined in the system's maintenance plan. This letter should be included with the Letter of Certification filed with the Health Authority.

### *Non-Residential Waste Design Flow Tables*

Use Table 2-3 to determine the Daily Design Flow for non-residential facilities.

Where commercial kitchen equipment is used, high-strength waste is expected. Therefore, a Professional should design the system or review the design of the system.

Where a Type 3 system is used, or where Daily Design Flow exceeds 9,100 Litres, the SSR requires that the system must be designed/installed by a Professional.

**Table 2-3 Facility Daily Design Flow Rates**

Type of facility	Unit	Design Flow Rate (litres/ imperial gallons per day)	
<b>INSTITUTIONAL</b>	<b>UNIT</b>	<b>DESIGN FLOW RATE (LITRES/GALLON PER DAY)</b>	
Assembly Halls no kitchen	Per person	8	1.75
Assembly Halls with kitchen	Per person	9	2
Church no kitchen	Per seat	9	2
Church with kitchen	Per seat	26	6
Church Suppers	Per person	45	10
Note: Where large functions are held, consider type of function (example, dance) and size accordingly			
Town Hall	Per seat	19	4
Fire station		Individual design	
<b>MEDICAL/PERSONAL CARE</b>	<b>UNIT</b>	<b>DESIGN FLOW RATE (LITRES/GALLON PER DAY)</b>	
Hospital	Per bed	409	90
Including laundry	Per bed	750	165
Excluding laundry	Per bed	550	120
Hospital mental	Per bed	340	75
Hospital mental, add per employee	Per employee	23	5
Special care home	Per resident	910	200
Special care home, add per employee	Per employee	45	10
Medical Office Doctors nurses medical staff	Per person	273	60
Medical office, Office staff add	Per person	73	16
Medical office, Patient add	Per person	23	5
Dental Office	Per chair	757	166
Dental office, Staff add	Per person	132	29
<b>SCHOOLS</b>	<b>UNIT</b>	<b>DESIGN FLOW RATE (LITRES/GALLON PER DAY)</b>	
Cafeteria and gym and shower (add to base flow)	Per student	68	15
Cafeteria only (add to base flow)	Per student	45	10
Gym only (add to base flow)	Per student	45	10
Washrooms only base flow			
Elementary	Per student	26	6
High school	Per student	45	10
Junior High school	Per student	34	7.5
Boarding school Resident student	Per student	136	30
Boarding school non resident staff	Per person	45	10
<b>PRISON</b>	<b>UNIT</b>	<b>DESIGN FLOW RATE (LITRES/I GALLONS PER DAY)</b>	
Prison	Per inmate	136	30
Add for personnel	Per person	23	5

Type of facility	Unit	Design Flow Rate (litres/ imperial gallons per day)	
<b>FOOD SERVICE</b>	<b>UNIT</b>	<b>DESIGN FLOW RATE (LITRES/I GALLONS PER DAY)</b>	
Bar/lounge/pub	Per seat	125	27
Bar/lounge/pub (alternatively, use higher flow obtained)	Per customer	8	1.76
Taverns/Bars/Lounges with minimal food service	Per seat	125	27
Restaurant	Per seat	90	20
24 hour restaurant	Per seat	200	44
24 hr highway and showers	Per seat	400	88
Banquet rooms	Per seat, each banquet	30	6.5
Night Club/Restaurant	Per seat	125	27
Dining rooms and lounges	Per m <sup>2</sup> of dining area	97	21
Take out	Per m <sup>2</sup> (total area)	22	5
Banquet and Dining rooms	Per meal	18	4
Caterers (in addition to normal flows)	Per patron	45	10
Coffee Shop	Per customer	19	4
Coffee shop, add for employees	Per employee	36	8
Bakery (Sanitary only)	Per employee	68	15
<b>COMMERCIAL AIRPORT</b>	<b>UNIT</b>	<b>DESIGN FLOW RATE (LITRES/I GALLONS PER DAY)</b>	
Airport	Per passenger	9	2
Airport, add for employees	Per employee	41	9
<b>COMMERCIAL BEAUTY SALON</b>	<b>UNIT</b>	<b>DESIGN FLOW RATE (LITRES/I GALLONS PER DAY)</b>	
Beauty salon	Per station	400	88
Beauty salon, add for personnel	Per person	38	8
<b>COMMERCIAL VETERINARY</b>	<b>UNIT</b>	<b>DESIGN FLOW RATE (LITRES/I GALLONS PER DAY)</b>	
Veterinary clinic (3 doctors or less) No boarding	Total	2,900	638
Veterinary clinic (3 doctor or less) Boarding	Total	5,700	1,254
Dog kennel	Per enclosure	73	16
<b>COMMERCIAL LAUNDRY</b>	<b>UNIT</b>	<b>DESIGN FLOW RATE (LITRES/I GALLONS PER DAY)</b>	
Laundromat In apartment	Per machine	1,135	250

Type of facility	Unit	Design Flow Rate (litres/ imperial gallons per day)	
<b>RETAIL</b>	<b>UNIT</b>	<b>DESIGN FLOW RATE (LITRES/I GALLONS PER DAY)</b>	
Department store	Per toilet room	1,513	333
Department store, add for employees	Per employee	36	8
Shopping centre	Per employee	40	9
Shopping centre Washrooms only	Per m <sup>2</sup> of store space	5	1
Shopping centre Toilet rooms	Each	1,665	366
Shopping Centre excluding café or laundry	Per m <sup>2</sup>	7	1.5
Shopping centre large dry goods centre	Per m <sup>2</sup>	2	0.45
Shopping centre Large supermarket & meat department (no garburator)	Per m <sup>2</sup>	3	0.6
Shopping centre Small dry goods store	Each	379	83
<b>COMMERCIAL AUTOMOTIVE</b>	<b>UNIT</b>	<b>DESIGN FLOW RATE (LITRES/I GALLONS PER DAY)</b>	
Automobile gas station	Per vehicle	22	5
Automobile gas station island	Per island	2,000	440
Car wash	Per car	189	42
Truck wash	Per truck	378	83
<b>COMMERCIAL HOSPITALITY</b>	<b>UNIT</b>	<b>DESIGN FLOW RATE (LITRES/I GALLONS PER DAY)</b>	
Motel	Per unit	318	70
Motel	Per housekeeping unit	455	100
Motel Bed & breakfast	Per person	227	50
Hotel	Per unit	366	80
Hotel, add for non resident staff	Per employee	36	8
Dormitory Bunkhouse	Per person	91	20
Senior citizen home	Per resident	910	200
Day care centres	Per child	73	16
Day care centres, add for staff	Per employee	73	16
<b>INDUSTRIAL/OFFICE</b>	<b>UNIT</b>	<b>DESIGN FLOW RATE (LITRES/GALLONS PER DAY)</b>	
Industrial buildings Excluding industrial waste, cafeteria and showers	Per employee	45	10
Industrial buildings Excluding industrial waste, including showers	Per employee	75	16
Heavy Industry Excluding industrial waste, including cafeteria and shower	Per employee	132	29
Warehouse	Per employee	132	29
Industrial Park	Per employee	68	15
Office No cafeteria	Per employee	50	11
Office Including cafeteria	Per employee	76	16

Type of facility	Unit	Design Flow Rate (litres/ imperial gallons per day)	
<b>RECREATION CAMPING</b>	<b>UNIT</b>	<b>DESIGN FLOW RATE (LITRES/I GALLONS PER DAY)</b>	
Campgrounds tents only	Per site	180	39
Campground, trailers water, sewer and electrical connection at site; non year round	Per site	365	80
Having year round operation	Per site	545	120
Cabin Resort	Per person	318	70
Day camps no meal	Per person	38	8
Day camps with meals	Per person	68	15
Day camps (primitive)	Per person	40	9
Construction camps flush toilets	Per person	189	41
Construction camps no flush toilets	Per person	123	27
Youth camps	Per person	189	41
Work camps	Per bed	227	50
Luxury camps	Per person	378	83
Cottages & small seasonal dwellings, no washroom, no laundry or kitchen (central comfort station)	Per bedroom	189	42
Cottages & small seasonal dwellings, with washrooms, non commercial use (residential accessory)	Per bedroom	568	125
<b>PARKS AND PICNIC GROUNDS</b>	<b>UNIT</b>	<b>DESIGN FLOW RATE (LITRES/I GALLONS PER DAY)</b>	
Picnic and fairgrounds with bath houses, showers, toilets	Per person	38	8
Picnic and fairgrounds with toilet only	Per person	18	4
Beaches with showers & toilets	Per person	40	9
Visitor Centre	Per person	23	5
Country club Resident present	Per person	372	81
Country club Non resident	Per person	95	20
Country club Showers in use	Per fixture	1,800	395
Country club Water closet	Per fixture	550	120
Country club Lavatory	Per fixture	350	77
Country club Urinals – hand flush	Per fixture	350	77
Country clubs Showers	Per person	40	9
Country club, add for day staff	Per employee	50	11

Type of facility	Unit	Design Flow Rate (litres/ imperial gallons per day)	
<b>RECREATION SPORT</b>	<b>UNIT</b>	<b>DESIGN FLOW RATE (LITRES/I GALLONS PER DAY)</b>	
Bowling Alleys bar or restaurant	Per alley	800	175
Bowling alleys no bar or restaurant	Per alley	105	23
Ice rink	Per seat	11	2.5
Ice rink, add for participants	Per person	38	8
Stadium	Per seat	14	3
Swimming pool	Per customer	14	3
Swimming pool	Per m <sup>2</sup>	50	11
Water slide park	Per visitor	15	3.3
Gym, participants	Per person	38	8
Tennis/Racquetball no food	Per court	946	208
Ski areas no cafeteria	Per person	38	8
Outdoor sport facilities, toilet waste only	Per person	19	4

**NOTES:**

Extreme care should be taken with facilities that use wax strippers, disinfectant cleaning chemicals, and where residents are using prescription drugs, in these cases a Professional should be consulted prior to system design. Facilities where mobile homes or trailers may connect to the system and discharge holding tank chemicals to the system also require extreme care, in these cases a Professional should be consulted prior to system design.

***Other Facility Daily Design Flows***

Where a facility is not included in the tables or where flows are expected to be higher or considerably lower than those provided in the tables, it is necessary to determine a Daily Design Flow based upon average flow information or upon occupancy/fixture count. In these cases it is recommended that a qualified Professional select an appropriate Daily Design Flow. Where flow records are used for design, mass loading should be considered.

In order to use the SPM Hydraulic Loading Rate Table 2-8, Mass Loading to the dispersal field should also be equivalent to residential effluent (as defined by the SPM Residential Sewage and Treatment Standards in Section 2.4), which could require additional pre-treatment processes and/or a larger dispersal field.

Daily Design Flow and type/quality of influent should be clearly stated on the filing document. System owners should be made aware of these design flows, the standards for influent quality, and the allowable average flows to the system. Owners should sign a written acknowledgement undertaking to use the system within these allowable flows and to observe the source control policy in the system maintenance manual, and this sign off should be included with the Letter of Certification.

## **2.2.2 Flow Reduction Devices — Mass Loading**

The use of flow reduction devices should not reduce Daily Design Flow rates; and where flow records are used for design, mass loading should be considered. See Appendix D for more information.

## **2.2.3 Garbage Grinders (Garburators)**

Where garbage grinders or garburators are used, an increase of minimum 50 per cent in Daily Design Flow is needed for the treatment facilities and dispersal of effluent (i.e., septic tank AND dispersal field), so that the system can accommodate the increase in mass loading.

Also note that oil and grease levels will increase when using garburators. A grease interceptor could be needed.

NOTE: Garbage grinders increase BOD 20–65%, TSS 40–90%, O&G 70–150% (Ref. EPA Onsite Wastewater Treatment Systems Special Issues Fact Sheet 2).
---

## ***2.3 Determination of Treatment and Dispersal System Needs***

---

### **2.3.1 Process Selection**

Selection and design of the level of treatment and effluent dispersal systems primarily depend on Daily Design Flow, soil conditions and vertical separation.

Selection also depends on site conditions such as constraints of the site, horizontal setbacks, and the land area available for the dispersal system.

### **2.3.2 Soil and Site Investigation Standards**

#### **2.3.2.1 SOILS AND WATER TABLE INVESTIGATION**

For purposes of system design, the soil conditions in the dispersal and receiving areas should be investigated. The number of soil tests performed and the location where tests will take place depend on the variability of the soils.

Excessive excavation of sensitive soils/sites should be avoided because excavation may degrade the soils.

Soil characteristics should be evaluated and described in accordance with the following recognized methods:

- Canadian System of Soil Classification, 3rd Edition;

- CanSIS Manual for Describing Soils in the Field (Working Group on Soil Survey Data 1975);
- Field Book for Describing and Sampling Soils, Version 2.0. Schoeneberger, P.J., D.A. Wysocki, E.C. Benham, and W.D. Broderson (editors), 2002. National Soil Survey Center, Natural Resources Conservation Service, United States Department of Agriculture (USDA), Lincoln, Nebraska.  
<http://soils.usda.gov/technical/fieldbook/>; and,
- Standard Practice for Subsurface Site Characterization of Test Pits for On-Site Septic Systems (ASTM, D 5921 – 96; re-approved 2003).

Permeameter or percolation tests should be performed in accordance with the methods described in Appendix E, and should be repeated at least four times to arrive at a reliable value.

Soil investigation should include, at a minimum:

### **Test pits (observation holes)**

- Two test pits (observation holes) excavated to a minimum depth of 1.2 metres, or to refusal (where you cannot dig further), whichever is shallower.
  - The appropriate number of test pits will depend on the size of the drainfield area and the variability of soil conditions.
  - The appropriate depth of the test pits is that which provides soil and water table information. This is a minimum of 0.9 m below the proposed infiltrative surface;
  - Where auger holes are used, a minimum of two observation test pits should be excavated to confirm auger test results;
  - Test pits should minimize the impact on dispersal and receiving areas from pits and machinery; and,
  - Where a zero discharge lagoon is planned, test pits should be a minimum of 3 m in depth, should penetrate a minimum of 1 m below proposed lagoon depth. Typically 2 test pits for 1 to 3 bedroom flows are needed. For higher flows more could be necessary. Test borings to greater depth may be indicated where sand lenses or rock outcrops are suspected.

### **Soils profile**

- A description of the soil profile, including the soil texture, structure, consistence (rupture resistance), colour, at the depth of the proposed infiltration surface;
  - Where a zero discharge lagoon is planned, soil permeability and soil characteristics should be determined at appropriate depths/locations for planning of berm and excavation construction.
- A description of key measured depths, including soil redoximorphic features (mottling and gleying), roots, and total depth of each pit; and,
- Determining the depth of the flow restrictive horizon(s), water table and expected seasonal high water table (SHWT) including perched high water table (PHWT).

- This could require long-term monitoring of water table: monitoring standpipes or test pits during wet season conditions (typically October through May).
- For systems with Daily Design Flow of less than 9,100 L/day characterization of the water table to 1.2 m is sufficient except where depth of installation or other factors need deeper investigation.
- A blank form that can be used in recording the soil profile is provided in Appendix S.

### **Soil permeability**

- Permeability tests should be performed (permeameter, percolation test, ring infiltrometer, or other standard tests);
  - where the percolation test is used, the minimum number of tests is four tests at separate locations
  - where the constant head borehole permeameter is used, the minimum number of tests is four at separate locations; and,
  - additional tests could be required to achieve consistent results.
- Where a zero discharge lagoon is planned, the AP should determine soil permeability at the appropriate depths for the lagoon base and the berm area.

### **2.3.2.2 SITE INVESTIGATION REPORT**

A site investigation report should include, at a minimum:

- a plan (to scale) showing all factors needed for design;
- a description of soils characteristics and soil permeability;
- an estimation of water table, Seasonal High Water Table (SHWT) and limiting layers in the soils including an estimate of how the effluent will flow away from the discharge area;
- a description of underlying soils and rock;
- areas of imported fill materials;
- the location of all features relevant to dispersal area siting — including surface water, water supplies, services, breakouts/drains, and proposed and existing structures;
- a description of the site topography — including slope, slope type and slope location for proposed discharge area;
  - Also include % deflection of concave slopes. (*See Part 3 Section 3.8, sand mounds*) where a sand mound or at grade bed is being considered;
- potential reserve areas;
- site drainage and hydrology of the site;
- site vegetation and history of how the site was used;

- existing dispersal systems; and,
- easements and covenants — including rights of way, property line location, zoning, and statutory building scheme etc.

### 2.3.3 Vertical and Horizontal Separation Standards — Boundary Performance

#### 2.3.3.1 PERFORMANCE STANDARDS

Prior to effluent reaching the groundwater table or restrictive layer below the dispersal area, or reaching a breakout, source of drinking water etc., effluent treatment should occur and certain performance standards should be met. See Appendix F for more information.

In B.C., the industry currently finds it is more practical to utilize vertical and horizontal separation standards rather than monitor boundary performance. However, the Authorized Person should always consider the purpose of vertical and horizontal separation. For example:

- the AP should be prepared to increase vertical separation when the level of risk or the soil/water conditions of a site are in jeopardy.

Where performance standards are used in design by an AP to reduce the vertical and/or critical horizontal setbacks of the SPM, compliance with these standards should be assured. This should include monitoring as part of providing assurance of compliance at boundaries. See Appendix F.

#### 2.3.3.2 VERTICAL SEPARATION (VS)

##### *Vertical Separation Standards*

Table 2-4 and Table 2-5 show the minimum allowable long-term and sustainable unsaturated vertical separation, depending on the level of treatment.

NOTE: Conventional trenches and sand mounds/sand-lined trenches are covered in separate tables.

The minimum vertical separation is the unsaturated vertical distance from the infiltration surface (trench bottom, bed base or drip dispersal tube) to the seasonal high water table or limiting layer (e.g., clay, rock). See Figure 2-1 Vertical Separation between the Infiltrative Surface and the Restrictive Layer.

In addition to minimum **as constructed** vertical separation (total vertical separation), the tables also define the minimum part of the vertical separation that needs to be achieved within the **native soil**.

**Figure 2-1 Vertical Separation between the Infiltrative Surface and the Restrictive Layer.**

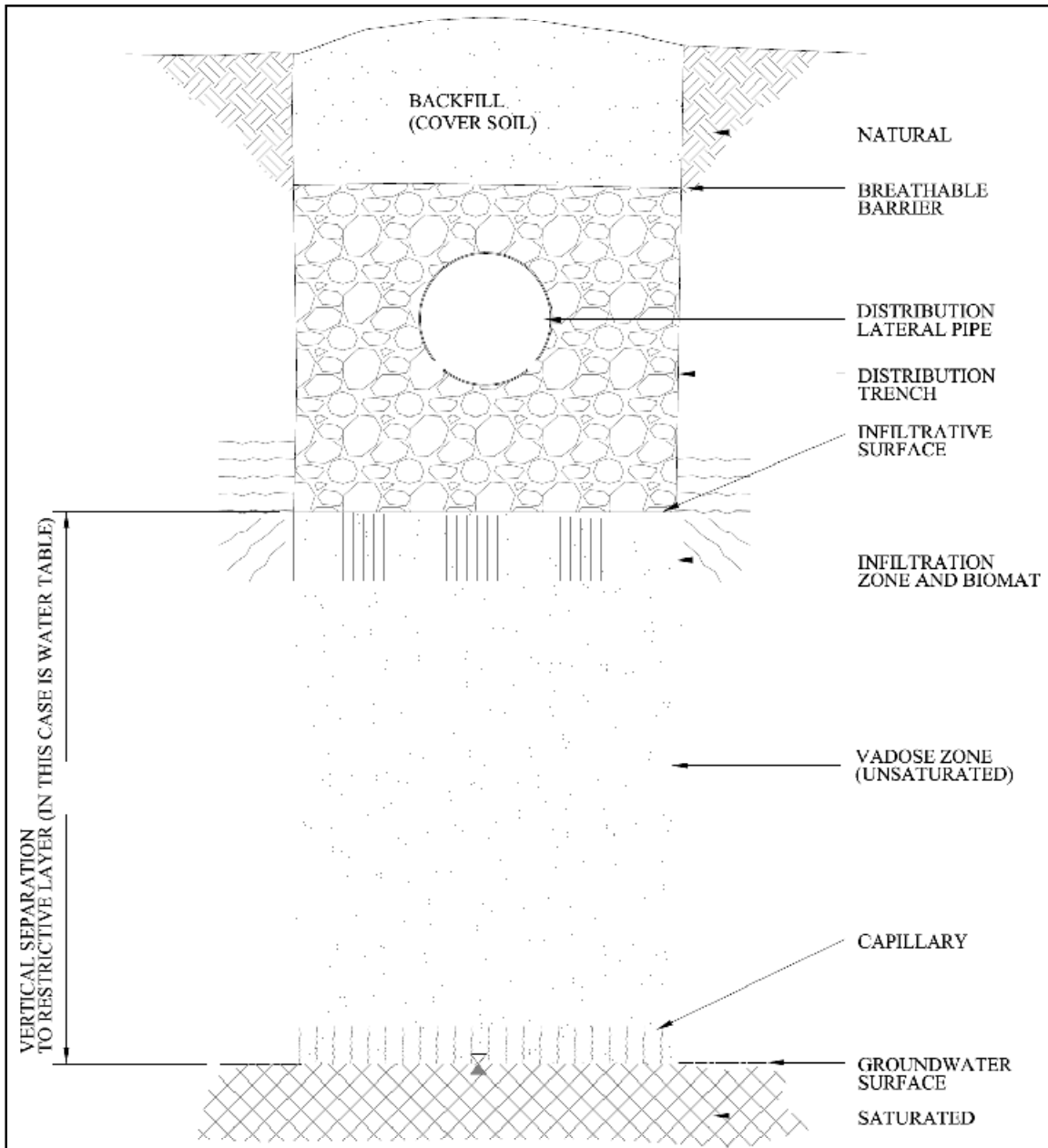

*Increasing Vertical Separation*

The vertical separation standards in Table 2-4 and Table 2-5 are minimum values. In some cases it could be necessary to increase the vertical separation values. See Appendix F.

Vertical separation could need to be increased where:

- there is a concern over groundwater mounding under the dispersal field;

- a site is over fractured rock, is over an unconfined aquifer or a community well is affected;
- subsurface flow is expected to be primarily vertical, (e.g., above fractured rock or gravel) leading to an aquifer that supplies drinking water. Or where flow is primarily vertical to a shallow unconfined aquifer that supplies drinking water or it is connected to nearby surface water. In these circumstances, consideration should be given to increasing Vertical Separation in order to remove pathogens;
- in coarser soils, where biomat is a key element in the removal of pathogens. Where reduced biomat is expected (under-loaded fields, alternating fields, seasonal use, and high loadings with treated effluent) consideration should be given to increasing vertical separation; and,
- when increased hydraulic loading rates are used for Type 2 effluent in highly permeable soils, consideration should be given to increasing vertical separation to ensure pathogens are removed.

### *Vertical Separation — Trench and Bed Systems*

Table 2-4 provides standards for vertical separation for conventional trench, seepage bed and at grade systems.

Table 2-4 is also to be used for sand fill systems (raised systems) that do not meet the standards of Part 2 and Part 3 of the SPM for sand mounds/sand-lined trenches.

**Table 2-4 Minimum Vertical Separation (VS) for Trench, At Grade or Seepage Bed Systems**

PRE-TREATMENT AND DISPERSAL TYPE	MINIMUM VERTICAL SEPARATION IN NATIVESOIL	MINIMUM AS CONSTRUCTED VERTICAL SEPARATION	NOTES
Type 1 or 2, gravity distribution	36" (91 cm)	36" (91 cm)	No fill to be used below gravity system. Recommended 42" (107 cm) VS in Loamy Sand (or coarser) or over fractured rock or over unconfined aquifers.
Type 1, pressure distribution	24" (61 cm)	24" (61 cm)	Recommended 30" (76 cm) minimum VS in soils coarser than Loamy Fine Sand over fractured rock or unconfined aquifers.
Type 2, pressure distribution	24" (61 cm)	24" (61 cm)	Where Type 2 effluent is applied at higher loading rates than Type 1, consideration should be given to increasing VS to ensure adequate pathogen removal, particularly in coarser soils.
Type 2, pressure distribution, reduced soil depth	18" (46 cm)	30" (76 cm)	Where native soil VS is less than 24" minimum final VS is 30" (76 cm)
Type 3, pressure distribution	18" (46 cm)	18" (46 cm)	
Type 3, pressure distribution, reduced soil depth	6" (15 cm)	24" (61 cm)	Where native soil VS is less than 12", minimum final VS is 24" (61 cm)

***Vertical Separation and Sand Depth for Sand Mounds and Sand-lined Trenches***

Table 2-5 is a linked standard that should only be used where system is designed and dosed following all standards of the SPM for sand mounds or sand-lined trenches as provided in Part 2 and in Part 3 of the manual. Linear Loading Rates should be used for the design.

Timed dosing designed following the provisions of Section 3.8 should be used where vertical separation in native soil is 18" or less.

In all other cases Table 2-4 applies.

**Table 2-5 Minimum Vertical Separation for Sand Mounds, Sand-lined Trenches**

RESTRICTIVE LAYER/BASAL AREA SOILS	MINIMUM VERTICAL SEPARATION IN NATIVE SOIL
SHWT (Seasonal High Water Table)	10" (25 cm)
Permanent water table	24" (61 cm)
Fine sand/Loamy Fine Sand or coarser soils over: Fractured bedrock	24" (61 cm)
Fractured bedrock, under finer soils	18" (46 cm)
Non fractured bedrock or other low permeability restrictive layer	10" (25 cm)

**Minimum as constructed vertical separation and sand depth should be as described below.**

**NOTES:**

Rock is divided into two classes for the purpose of this table: crevice, and non-crevice impermeable. Treatment may continue in non-crevice semi-permeable and crevice bedrock depending on their characteristics, however there is a risk of aquifer contamination due to rapid flow in the fractures.

**In all cases, minimum as constructed vertical separation (including the sand) should:**

- be 30" (76 cm) for Types 1 and 2 effluent;
- be 24" (61 cm) for Type 3 effluent;

AND include the minimum sand depth specified below.

**Sand mound sand media depth below bed should:**

- have a minimum of 18" (46 cm) of mound sand below the bed with pressure distribution, dosing design per Section 3.8; and,
- have a minimum of 12" (30.5 cm) with timed (>18 × per day at Daily Design Flow, dosing design per Section 3.8) dosed pressure distribution.

Where soils are sand, gravel or gravelly sand or in other soils where Type 2 10/10 effluent is needed (by site capability tables Section 2.3.6); minimum sand depth should be 24" (61 cm).

**Sand-lined trench sand media depth below bed should:**

- have a minimum of 24" (61 cm) of mound sand with pressure distribution, dosing design per Section 3.8 (linked standard).

### 2.3.3.3 HORIZONTAL SEPARATION (SETBACKS)

#### *Horizontal Setback Distances for Critical Setbacks*

Setbacks are presented in Table 2-6 and footnotes are the recommended **minimum** standards for all sewerage systems. These are recommended minimum standards and effort should always be made to accommodate the greatest setback possible from

drinking water, fresh water and well water, especially in unconfined aquifers, shallow wells, springs, surface sources and high pumping rate wells. If in doubt, contact a professional with competence in the field of hydrogeology or geotechnical engineering.

**It is strongly recommended that any deviation from the table only be made by a Professional with competence in the field of hydrogeology or geotechnical engineering.** This deviation should only be made after reasonable effort has been made to comply with the table, and such deviation should address the assurance of environmental performance standards equal to or exceeding those that would be provided by the setback standards of the table, including adequate provision for system and environmental monitoring. See Appendix F.

All setbacks should be measured from the infiltrative surface (i.e., trench wall, edge of infiltration bed or, in the case of a mound, edge of the needed basal area, in the case of a lagoon, the inside top of berm) to the nearest edge of the restriction (i.e., well, building).

**Table 2-6 Horizontal Setback Distances for Critical Setbacks**

Distance to	From dispersal system (metres/feet)				From watertight subsurface treatment tank (metres/feet)
	LAGOON	TYPE 1/2	TYPE 1/2	TYPE 3	
		GRAVITY DIST.	PRESSURE DIST.	PRESSURE DIST.	
Source of drinking water, well or water suction lines	30 m / 100 ft.				15 m / 50 ft.
High pumping rate Water Supply System well	60 m / 200 ft				30 m / 100 ft.
High pumping rate Water Supply System well in unconfined aquifer	90 m/300 ft.				
Break-out point or downslope drain (including perimeter drain)	15 m / 50 ft.	15 m / 50 ft.	7.5 m / 25 ft.	7.5 m / 25 ft.	1 m / 3 ft.
Fresh water	30 m / 100 ft	30 m / 100 ft.		15 m / 50 ft.	10 m / 33 ft.
Fresh water (seasonal)	30 m / 100 ft	30 m / 100 ft.	15 m / 50 ft.		
Marine water	30 m / 100 ft	15 m / 50 ft.			

**NOTES:**

Reduction of horizontal setback for pressure distribution is not applied for gravelly sand or coarse to medium sand/loamy sand soils. On these coarser soils, setback credit is only applicable for sand mounds/sand-lined trenches using a minimum of 610 mm (24") sand.

Perimeter or other subsurface drains are a breakout. If the drain discharges to a dispersal area designed per the SPM to disperse effluent, the drain is not a breakout.

Upslope separation to an interception drain or other drain should be a minimum of 3m (10') for slopes of 5% or greater. Where the slope is lower or the drain is over 1.2 m (48") deep, this distance may not be sufficient and use of subsurface dam (impermeable barrier) or increase of setback to downslope drain standard is required.

'Fresh water (seasonal)' is defined, for the purpose of this table as an intermittent fresh water body that is incapable of contaminating a source of drinking water whether directly or indirectly. This definition does not apply to a body of water contained in a properly-constructed culvert that is constructed to prevent the contamination of a watercourse by domestic sewage or effluent.

'Fresh water' is defined, for the purpose of this table, as a natural watercourse or source of fresh water, usually containing water but does not include ground water or water in a culvert that is constructed to prevent the contamination of a watercourse by domestic sewage or effluent. This includes fresh tidal water.

A 'high pumping rate Water Supply System well' for the purpose of determining horizontal setbacks means a well or well group supplying a water supply system providing potable water supply to more than 500 persons during any 24 hour period.

Water setbacks are measured from edge of high water or tideline.

Water suction line is any part of any pipe or conduit conveying drinking water at pressure below atmospheric.

Setback from a lagoon to a dwelling should in all cases be a minimum of 200' (60 m).

APs are to note that well protection is addressed by several regulations, including the *Drinking Water Protection Act* and Regulation, the Ground Water Protection Regulation and the Sanitary Regulation. See Appendix F.

It must also be noted that section 42 of the Sanitary Regulations (which, like the SSR, are established under the Health Act), prohibits the installation of wells within 100 feet of probable sources of contamination. The B.C. Supreme Court has held, in *Mortensen v. Nelson* [2004] B.C.J. 2283, that a septic field is a "probable source of contamination". Although section 42 of the Sanitary Regulations does not expressly prohibit the installation of sewerage systems within 100 feet of existing wells, there is a potential that a court may interpret it that way. The Ministry of Health is presently reviewing the relationship between section 42 of the Sanitary Regulations and the SSR. In the meanwhile, owners and Authorized Persons should consult their own legal counsel before taking any steps to install a sewerage system within 100 feet of existing wells.

#### REDUCTION OR INCREASE IN SETBACK TO SOURCE OF DRINKING WATER OR FRESH WATER

Any reduction of critical horizontal setback distances specified in Table 2-6 to a source of drinking water or to fresh water should be

- reported to the Health Authority;
- verified by the site/soil evaluation report, and;
- approved by a Professional with competence in the field of hydrogeology or geotechnical engineering,

and monitoring should be in place to verify compliance with effluent quality parameters at the point of discharge to the dispersal area to assure the effluent quality discharged to the dispersal area. Any setback reduction from a source of drinking water or to fresh water which is likely to become a source of drinking water should also include mandatory environmental monitoring of compliance with quality standards (boundary performance), developed as per Appendix F, through the use of monitoring wells.

Monitoring wells and schedule of monitoring should be designed by a professional who has competency in the field of hydrogeology or geotechnical engineering to adequately assure monitoring of compliance with the boundary performance standards developed as per Appendix F. This should include monitoring of background contaminant levels.

Any setback from freshwater or source of drinking water less than 15 m/ 50 ft. should be accompanied by an active local government by-law outlining monitoring and maintenance conditions.

In the case of wells in unconfined aquifers, high pumping rate community wells or surface water sources/springs, the AP may consider the recommended minimum setback provided in the table to be insufficient. In such a case, the setbacks should be approved by a qualified Professional with competence in the field of hydrogeology or geotechnical engineering, and monitoring put in place (as above) to verify compliance with effluent quality and environmental monitoring parameters.

When considering suitable setbacks to high pumping rate wells, an area-based hydrogeological study is recommended.

In the case of water suction lines, reduction in setback should only be made based on design of the suction line and works for prevention of contamination by a professional. Monitoring of the water supplied from the suction line prior to use should be in place to assure absence of contamination if the setback is reduced.

APs are to note that well protection is addressed by several regulations, including the *Drinking Water Protection Act* and Regulation, the Ground Water Protection Regulation and the Sanitary Regulations. See Appendix F.

### *Horizontal Setback for Other Boundaries*

Setbacks are presented in Table 2-7 and information included in the footnotes provides the recommended **minimum** standards for all sewerage systems.

Authorized Persons should only deviate from setbacks presented in Table 2-7 where the reduction will not contribute to the creation of a health hazard. It is also recommended that performance standards should still be met if a departure occurs.

Setbacks are measured per critical setbacks section (above).

**Table 2-7 Horizontal Setback Distances for other setbacks**

DISTANCE TO	From dispersal system (METRES/FEET)			FROM WATERTIGHT SUBSURFACE TREATMENT TANK (METRES/FEET)
	LAGOON	TYPE 1/2	TYPE 3	
Property lines	15 m / 50 ft.	3 m / 10 ft.	1.5 m / 5 ft.	1 m / 3 ft.
Water lines (pressure)	3 m / 10 ft.	3 m / 10 ft.	1 m / 3 ft.	1 m / 3 ft.
Building or structure non-dwelling (where there is not a perimeter drain)	15 m / 50 ft.	1.5 m / 5 ft.	1 m / 3 ft.	1 m / 3 ft.
Building dwelling (where there is not a perimeter drain)	60 m / 200 ft.	3 m / 10 ft.	2 m / 6 ft.	1 m / 3 ft.
Utility services	1.5 m / 5 ft.	1 m / 3 ft.	1 m / 3 ft.	1 m / 3 ft.

**Note:**

For swimming pools with no external subsurface drainage, use the horizontal setbacks for non-dwelling building or structure. Consider access to tanks.

***Sand Mounds and Sand-lined Trenches — Horizontal Setbacks***

In the case of sand mound and sand-lined trenches there is an expectation of treatment within the sand media. In these cases:

- a) for a mound system, the setback is measured from the edge of the needed basal area. See Part 3 for determination of needed basal area (linked standard);
- b) for a system where the mound bed is dosed with Type 3 effluent, the setback is measured from the edge of the mound bed; and,
- c) for sand-lined trenches, the setback is measured from the edge of the trench or filter basal area.

Where a sand mound or sand-lined trench forms part of a Type 3 system, and setback reduction to Type 3 standard is part of the design, monitoring should be in place as for any Type 3 system.

**2.3.4 Hydraulic Loading Rate (HLR) Standards**

The hydraulic loading rate is the amount of effluent that, over the long-term, can be applied each day per area of infiltrative surface (AIS) without failure of the infiltrative surface.

To select the hydraulic loading rate for an onsite sewerage system, determine the soil type.

First:

- determine soil texture/structure and consistence (See Section 2.3.2); and,
- determine soil permeability using either:
  - Percolation Test (*See Appendix E*);
  - Soil Hydraulic Conductivity (K) Test. (*See Appendix E*); and, recommendations for Field Tests of Soil Permeability (*See Appendix E*).

Second:

- then select from Table 2-8 the hydraulic loading rate for the type of effluent applied for each of these methods; and,
- if the methods give different HLR, the correct HLR is the lower of the two, resulting in a larger drainfield.

Example calculations:

$$\text{Daily Design Flow (DDF)} \div \text{hydraulic loading rate (HLR)} = \text{Area of Infiltrative Surface (AIS) needed}$$

$$\begin{aligned} \text{Example: Daily Design Flow of 1,136 L/day, HLR of 15 L/day/m}^2 \\ 1,136 \div 15 = 75.73 \text{ m}^2 \\ \text{Minimum Area of Infiltrative Surface (AIS) = 75.73 m}^2 \end{aligned}$$

$$\begin{aligned} \text{Example: Daily Design Flow of 250 G/day, HLR of 0.3 G/day/ft}^2 \\ 250 \div 0.3 = 833 \text{ ft}^2 \\ \text{Minimum Area of Infiltrative Surface (AIS) = 833 ft}^2 \end{aligned}$$

#### 2.3.4.1 SEEPAGE BED LOADING RATES

Table 2-8 applies to normal dispersal systems. For use with seepage beds these loading rates should be decreased by a factor of 1.35 to address oxygen flux considerations. In addition, seepage beds should not be wider than 4 m.

Note that this section does not apply to at grade beds (see Section 3.7.10 for that technology).

See Part 3 Section 3.7.9 (Seepage beds) for details of application.

Seepage bed area needed = AIS needed × 1.35

Example: Daily Design Flow of 1,136 L/day, HLR of 15 L/day/m<sup>2</sup>

To determine Minimum Area of Infiltrative Surface (AIS), use calculation  
in the previous section (2.3.4)

$$1,136 \div 15 = 75.73 \text{ m}^2$$

$$\text{AIS} = 75.73 \text{ m}^2$$

$$\text{Seepage bed area} = 75.73 \times 1.35 = 102.24 \text{ m}^2$$

#### 2.3.4.2 SAND MOUND AND SAND-LINED TRENCHES BASAL AREA HYDRAULIC LOADING RATES

Table 2-8 should be used for sizing the basal area for sand mounds and similar technology based upon the level of treatment expected at the basal interface. Basal loading rates are based upon Type 2 effluent for these systems, PROVIDED THAT they are designed, installed and maintained to the standards in Part 3 of this manual AND they meet the minimum sand depth standards of Section 2.3.3 (linked standard).

The increased Basal Hydraulic Loading Rates reflect the expectation of treatment in the filter media, which will reduce organic (mass) loading at the basal area, reducing the probability of failure at that interface due to biomat accumulation. See Appendix G Design HLR and Appendix H Sand Mound Systems for details. See Part 3 Section 3.8 for application of these technologies.

**NOTES:**

Where the increased Type 2 or 3 sand media hydraulic loading rates per Section 2.3.4.3 are used, timed dosing is needed and this should be designed to meet Hydraulic Application Rate standards per Part 3 Section 3.8 (linked standard).

Except where designed by a Professional, it is recommended that maximum basal loading rates are those for Type 2 effluent.

Where a sand mound/sand-lined trench is designed as part of a Type 3 system and this design is used to reduce separation or to increase loading rate at the basal area to Type 3 loading, the system should be designed by a Professional and adequate provisions for monitoring of performance to Type 3 standard should be in place.

See Section 3.8 for definition of basal area.

**REFERENCES:**

Shallow Intermittent Sand Filtration: Performance Evaluation, Jeannie Darby, Ph.D., P.E., George Tchobanoglous, Ph.D., P.E., M. Asri Nor, and David Maciolek, Small Flows Journal, Vol 2, issue 1, 1995.

Emerick, R.W., J. Manning, G. Tchobanoglous, and J.R. Darby, 2000. Impact of bacteria and dosing frequency on the removal of virus within intermittently dosed biological filters. In Small Flows Quarterly, Vol. 1, No. 1.

**Table 2-8 Soil Hydraulic Loading Rates for Residential Strength Wastewater**

SOIL CHARACTERISTICS <sup>1</sup>			PERCOLATION RATES (MIN/2.54 CM)	FIELD SATURATED HYDRAULIC CONDUCTIVITY (KFS) MM/DAY	WASTEWATER LOADING RATES IMPERIAL GALLONS/FT <sup>2</sup> /DAY (LITRES/M <sup>2</sup> /DAY)		
TEXTURE (USDA)	STRUCTURE				TYPE 1	TYPE 2	TYPE 3
	SHAPE	GRADE					
Gravelly sand	—	Single grain	< 2	>3,500	0.7 (34)	1.4 (68)	2.1 (103)
Coarse to medium sand/loamy sand	—	Single grain	2 – 5	1,500 – 3,500	0.6 (29)	1.2 (59)	1.8 (88)
Fine sand/fine loamy sand	—	Single grain	5 – 15	250 – 1,500	0.5 (25)	1.0 (49)	1.5 (75)
Sandy loam	Massive	structureless	20 – 30	125 – 250	0.3 (15)	0.45 (22)	0.6 (29)
	Platy	weak			0.3 (15)	0.45 (22)	0.6 (29)
		moderate, strong	not recommended	not recommended	not recommended		
	prismatic, blocky, granular	weak	10 – 20	250 – 500	0.4 (20)	0.7 (34)	1.0 (49)
moderate, strong		0.5 (25)			1.0 (49)	1.5 (74)	
Loam	massive	structureless	30 – 40	60 – 125	0.2 (10)	0.3 (15)	0.4 (20)
	Platy	weak			0.2 (10)	0.3 (15)	0.4 (20)
		moderate, strong	not recommended	not recommended	not recommended		
	prismatic, blocky, granular	weak	20 – 30	125 – 250	0.3 (15)	0.5 (24)	0.7 (34)
moderate, strong		0.4 (20)			0.8 (39)	1.2 (59)	
Silt loam, silt	massive	structureless	40 – 60	30 – 60	0.2 (10)	0.3 (15)	0.4 (20)
	platy	weak			0.2 (10)	0.3 (15)	0.4 (20)
		moderate, strong	not recommended	not recommended	not recommended		
	prismatic, blocky, granular	weak	20 – 40	60 – 250	0.3 (15)	0.5 (24)	0.7 (34)
moderate, strong		0.4 (20)			0.8 (39)	1.2 (59)	
Clay loam, sandy clay loam, silty clay loam	massive	structureless	60 – 90	15 – 30	not suitable	not suitable	not suitable
	platy	weak			not suitable	not recommended	not recommended
		moderate, strong	not suitable	not suitable	not suitable		
	prismatic, blocky, granular	weak	40 – 60	30 – 60	0.2 (10)	0.3 (15)	0.4 (20)
moderate, strong		0.3 (15)			0.45 (22)	0.6 (29)	
Sandy clay, silty clay, clay	massive	structureless	90 – > 120	< 5.0 – 60	not suitable	not suitable	not suitable
	platy	weak				not recommended	not recommended
		moderate, strong	not suitable	not suitable			
	prismatic, blocky, granular	weak	0.15 (7)	0.18 (9)			
moderate, strong		0.2 (10)	0.25 (13)				

**NOTES:**  
 Loading rates apply to the soil characteristics of the horizon in which the infiltration surface of the dispersal system should be situated, as well as the characteristics of the underlying soil. It is recommended that the loading rate be based on the horizon(s) with the most limiting soil characteristics.

It is recommended that other soil characteristics such as bulk density, coarse fragments (gravel), soil consistency, colour, the presence of roots, and moisture conditions be included in the loading rate assessment.

It is critical that loading rates be used only with effluent mass loadings and flows in accordance with the Daily Design Flow standards and Residential Sewage standards contained in the SPM. Using other effluent strengths or flows, requires that suitable peaking/safety factors are applied and conversion to equivalent mass loadings is made.

Where "Type 2 10/10" effluent is referred to, use HLR for Type 2 effluent. See Section 2.4.1.

### 2.3.4.3 SAND MEDIA HYDRAULIC LOADING RATE FOR SAND MOUNDS, AND SIMILAR TECHNOLOGY

The basal area loading is determined from Table 2-8 for native soil.

The maximum design hydraulic loading rate for the sand media is shown in Table 2-9.

**Table 2-9 Sand Media Loading Rates (for Mound Sand)**

Level of Treatment	Sand Media Loading Rate (L/day/m <sup>2</sup> )	Sand Media Loading Rate (IG/day/ft <sup>2</sup> )	Notes
Type 1	40	0.82	
Type 2	64	1.3	Timed dosing designed per standards of Part 3 Section 3.8 is needed if these higher loading rates are used. See Part 3 (linked standard).
Type 3	128	2.62	

The Mound Sand fill media should be carefully selected in order to ensure effluent is sufficiently treated and to prevent clogging:

- when effluent passes too quickly through the distribution bed, treatment is inadequate. Very coarse sands allow the effluent to pass too quickly through the distribution bed; and,
- when medium to fine sands are used, clogging will occur.

The fill needed is very similar to the fine aggregate used for concrete (ASTM Standard C33-97), except that the content of the fines is restricted. Table 2-10 shows the sieve analysis of the Mound Sand with the C33 sand specification for comparison.

**Table 2-10 Mound Sand and C33 Fine Aggregate Sieve Analysis**

Sieve Specification	Percent Passing	
	MOUND SAND	ASTM C33-97 FINE AGGREGATE
9.5 mm (3/8 inch)	100	100
4.75 mm (No. 4)	95 to 100	95 to 100
2.36 mm (No. 8)	80 to 100	80 to 100
1.18 mm (No. 16)	50 to 85	50 to 85
600 µm (No. 30)	25 to 60	25 to 60
300 µm (No. 50)	10 to 30	10 to 30
150 µm (No. 100)	<4	2 to 10
75 µm (No. 200)	<1	Not specified

**NOTE:**  
 Testing procedure for sieve testing of sand should include wash through (water washing) to ensure all fines are characterized.

Other sand specification consistent with industry standard practice should only be used with design and operation standards (including dose volume and frequency) suitable to the specification used. Alternate sand specifications are provided in Appendix H. Where none of the provided specifications can be met, the sand loading rate should be established by a Professional.

**2.3.4.4 LAGOON SYSTEMS**

Current research in the design and performance of these systems does not give information needed for Part 2 standards. The term “lagoon” as used in this manual refers only to B.C. zero discharge lagoons (see Part 3 Section 3.10).

Performance standards for these systems default to ensuring that the system does not contribute to the creation of a health hazard.

Sites are considered to be suitable for a Lagoon system when they have, in addition to the standards outlined in Table 2-6 and Table 2-7:

- a minimum area of 4.0 acres;
- soils with a soil percolation rate equal to or slower than 60 minutes/2.5 cm (1 inch) or Kfs less than 20 mm/day and no rock within 1 m vertical depth from the bottom of the lagoon;
- a minimum unsaturated vertical depth from the bottom of the lagoon of 0.91 m (36");
- a soil percolation rate equal to or slower than 60 minutes/2.5 cm (1 inch) or Kfs less than 15 mm/day at the lagoon base, below the lagoon berms and in the completed berms; and,
- a slope no greater than 12% (except where berms are designed by a Professional).

Sizing of lagoons is based upon the expected average flow. See Part 3.

Also see Part 3 for design, installation and specification standards and guidelines (linked standard).

## 2.3.5 Soil Linear Loading Rate (LLR) Standards

### 2.3.5.1 MOVEMENT OF EFFLUENT AWAY FROM THE DISCHARGE AREA

As effluent is applied to the dispersal area it should move away from the area, horizontally and/or vertically.

Linear Loading Rate (LLR) tables provide maximum LLR values to address movement of effluent away from the dispersal area and to address adequate oxygen transport to the infiltrative surface. Systems should be constructed as long and narrow as possible.

An AP could alternatively utilize groundwater mounding and linear loading calculations, however it is recommended that this method is undertaken by a professional or under the supervision of a professional. If this is the case, the design should clearly show how these considerations have been addressed and include details of the site investigation used.

### 2.3.5.2 SOIL LINEAR LOADING RATE TABLES

A determination of the linear hydraulic loading rate (LLR) is necessary in order to determine the minimum total system length along the contour (NOT for a single trench):

- the LLR is the rate of effluent moving into and away from the point of discharge;
- it is applicable wherever flows away from the discharge area are predominately; **horizontal** due to restrictive layer and/or where the groundwater table is **shallow**;
- LLR is independent of effluent quality;
- where vertical separation in native material to a low permeability layer or water table below the **infiltrative surface** in the discharge area and receiving area is over 120cm (48") for pressure distribution or over 152cm (60") for gravity distribution, the bottom row of the table provides maximum LLR values to address the need for adequate oxygen transfer to the infiltrative surface and soils below; and,
- LLR applies to flat and to sloping sites. See Figure 2-2 and Figure 2-3,
  - For flat or low slope sites with Daily Design Flow over 4,500 L/day (1000 IG/day), further calculation of groundwater mounding could be needed.

To select the LLR for an onsite sewerage system:

- determine how water will flow away from the discharge area (see Figure 2-2 and Figure 2-3);
- determine the soil vertical separation below the infiltrative surface (and downslope area),

- This should take into account soils in the field area and the receiving area within the standard horizontal setback to breakout downslope.
- For a sand mound this depth is the **soil** vertical separation, and the LLR is based upon the soil, not the sand;
- identify the soil type per Section 2.3.4 (HLR); and,
- select from Table 2-11 the LLR, this is the same for all types of effluent,
  - Soil texture and structure are determined as for the HLR (using Kfs or percolation rate to confirm soil texture/structure analysis), and the most conservative, or lowest, result for the soils should be used in the calculation of trench length.
  - For sites with slopes 15% to 20% LLR from the “10% and over” column of the table could be increased by a factor of 1.25 (not to exceed the maximum LLRs per the bottom row of the table). This increase should only be applied where vertical separation below the infiltrative surface is over 30.5 cm (12”).

To calculate minimum allowable system length from the LLR use the following calculations:

Daily Design Flow ÷ Linear Loading Rate = Length of System

Example: Daily Design Flow of 1,136 L/day, LLR of 35L/day/m

$1,136 \text{ L/day} \div 35 \text{ L/day/m} = 32.5 \text{ m}$

Minimum Length of System = 32.5 m

### 2.3.5.3 WHERE LLR STANDARDS CANNOT BE MET

For sand mounds and sand-lined trenches, where the soil vertical separation is less than or equal to 61cm (24"); LLR table standards should be met or water table mounding calculations, full-scale mounding tests or another appropriate standard method should be used to calculate a design linear loading rate and to address mounding concerns.

For systems other than sand mounds/sand lined trenches, and for sand mounds/sand lined trenches where soil vertical separation is over 61cm (24"), on sites where the LLR cannot be met due to site constraints:

- Strategies such as increasing vertical separation (example shallow or at grade placement), site remediation (example construction of a toe blanket) and site drainage (example interception drain) could be employed to increase allowable LLR.
- Further, systems utilizing pressure or Subsurface Drip distribution with low Hydraulic Application Rate timed dosing (per provisions of the relevant sections of Part 3 of the manual) will permit higher LLR.

- In these cases, for systems with Daily Design Flow less than 9092 L/day (2000 IG/day) LLR figures from the table can be increased by a factor of 1.25 (not to exceed the maximum LLRs per the bottom row of the table).
- For sand mounds and sand lined trenches this only applies where timed dosing meets the standards of Section 3.8.

Where LLR still cannot be met due to lot width constraint or in a repair situation:

- for systems with Daily Design Flow of less than 2,500 L/day (550 IG/day) AND soil vertical separation of 61 cm (24") or more, a system with maximum 75 L/day/m LLR could be constructed; and,
- in other cases water table mounding calculations, full-scale mounding tests or another appropriate standard method can be used to calculate a design linear loading rate. It is recommended that in this circumstance a Professional perform the calculation.

**Figure 2-2 Linear Loading Rate on a Slope, Showing Trench Cross Sections**

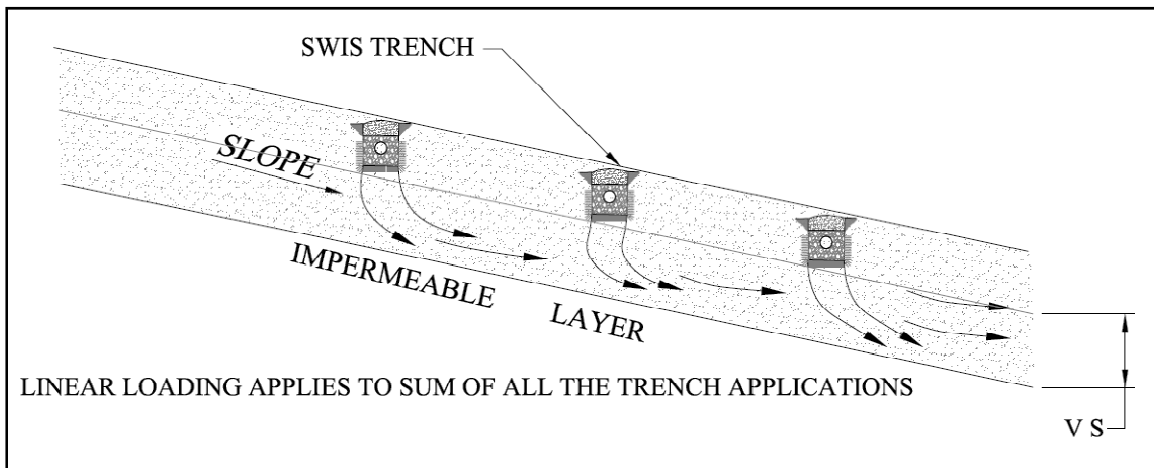
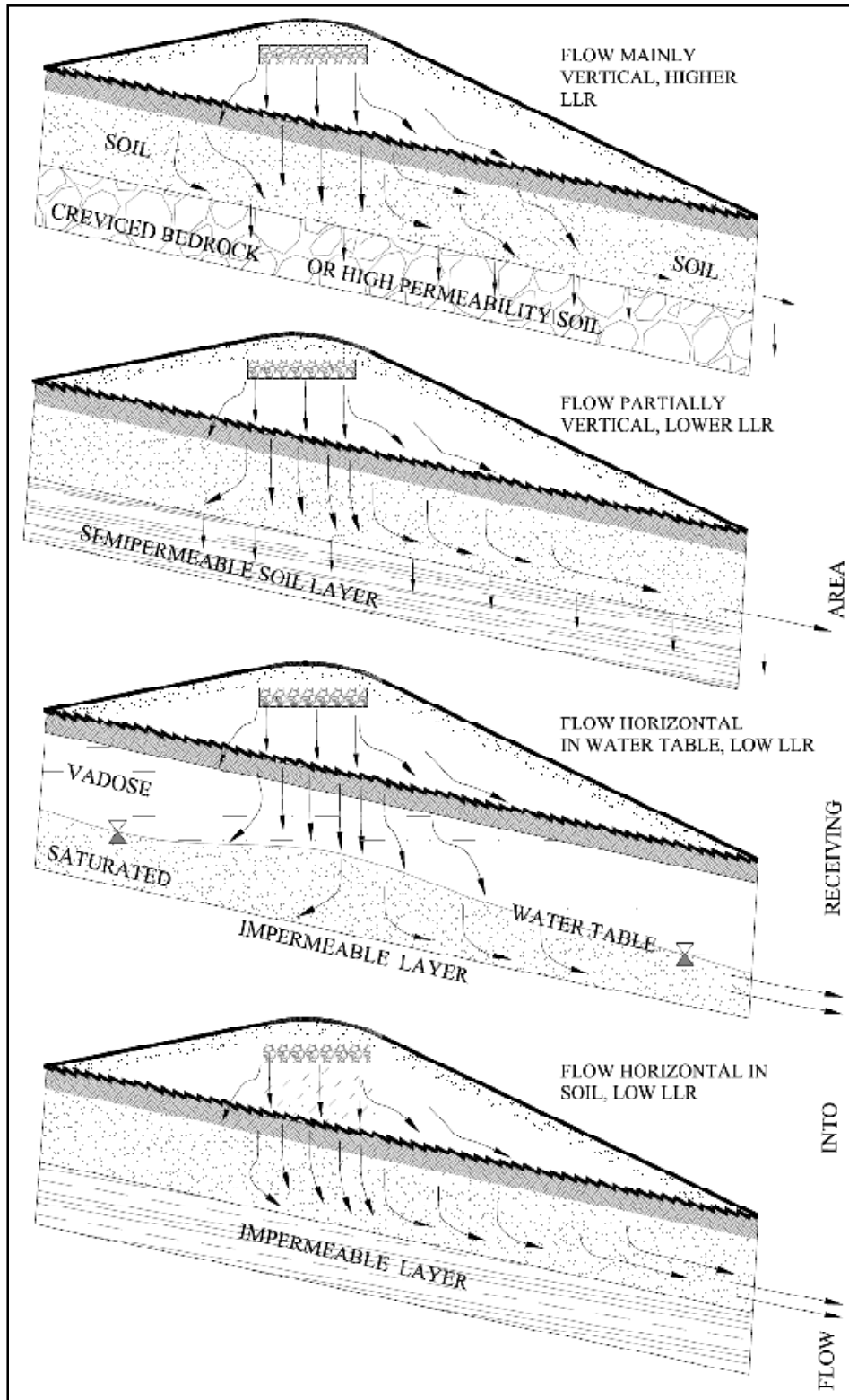

Figure 2-3 How Effluent Flows Away from a Discharge Area, and How this Affects LLR



**Table 2-11 Linear Loading Rates for Wastewater**

SOIL CHARACTERISTICS			SLOPE 0-4%						SLOPE 5-9%						SLOPE 10% AND OVER						
SOIL TEXTURE	SOIL STRUCTURE SHAPE	STRUCTURE STRENGTH/ GRADE	8" TO <12"		12" TO <24"		≥24"		8" TO <12"		12" TO <24"		≥24"		8" TO <12"		12" TO <24"		≥24"		
			IG/DAY/FT	L/DAY/M	IG/DAY/FT	L/DAY/M	IG/DAY/FT	L/DAY/M	IG/DAY/FT	L/DAY/M	IG/DAY/FT	L/DAY/M	IG/DAY/FT	L/DAY/M	IG/DAY/FT	L/DAY/M	IG/DAY/FT	L/DAY/M	IG/DAY/FT	L/DAY/M	
Gravelly sand	—	Single grain	3.3	49.7	4.2	62.1	5.0	74.5	4.2	62.1	5.0	74.5	5.8	86.9	5.0	74.5	5.8	86.9	6.7	99.3	
Coarse to medium sand/loamy sand	—	Single grain	3.3	49.7	4.2	62.1	5.0	74.5	4.2	62.1	5.0	74.5	5.8	86.9	5.0	74.5	5.8	86.9	6.7	99.3	
Fine sand and fine loamy sand	—	Single grain	2.9	43.5	3.7	55.9	4.6	68.3	3.3	49.7	4.2	62.1	5.0	74.5	4.2	62.1	5.0	74.5	5.8	86.9	
Sandy loam	massive	structureless	2.5	37.3	2.9	43.5	3.3	49.7	3.0	44.7	3.4	50.9	3.8	57.1	3.3	49.7	4.2	62.1	5.0	74.5	
		weak	2.5	37.3	2.9	43.5	3.3	49.7	3.0	44.7	3.4	50.9	3.8	57.1	3.3	49.7	4.2	62.1	5.0	74.5	
	platy	moderate, strong	0.0	0.0	0.0	0.0	0.0	0.0	0.0	0.0	0.0	0.0	0.0	0.0	0.0	0.0	0.0	0.0	0.0	0.0	
		prismatic, blocky, granular	weak	2.9	43.5	3.7	55.9	4.6	68.3	3.3	49.7	4.2	62.1	5.0	74.5	4.2	62.1	5.0	74.5	5.8	86.9
			moderate, strong	2.9	43.5	3.7	55.9	4.6	68.3	3.3	49.7	4.2	62.1	5.0	74.5	4.2	62.1	5.0	74.5	5.8	86.9
Loam	massive	structureless	1.7	24.8	1.9	28.6	2.2	32.3	2.0	29.8	2.2	33.5	2.7	39.7	2.2	33.5	2.7	39.7	3.1	45.9	
		weak	1.2	18.6	1.4	21.4	1.6	24.2	1.5	22.4	1.7	25.1	2.0	29.8	1.7	25.1	2.0	29.8	2.3	34.5	
	platy	moderate, strong	0.0	0.0	0.0	0.0	0.0	0.0	0.0	0.0	0.0	0.0	0.0	0.0	0.0	0.0	0.0	0.0	0.0	0.0	
		prismatic, blocky, granular	weak	2.5	37.3	2.9	43.5	3.3	49.7	2.7	41.0	3.2	47.2	3.6	53.4	3.0	44.7	3.4	50.9	3.8	57.1
			moderate, strong	2.7	41.0	3.2	47.2	3.6	53.4	3.0	44.7	3.4	50.9	3.8	57.1	3.2	48.4	3.7	54.6	4.1	60.8
Silt loam, silt	massive	structureless	1.7	24.8	2.1	31.0	2.5	37.3	1.8	27.3	2.2	33.5	2.7	39.7	2.0	29.8	2.4	36.0	2.8	42.2	
		weak	1.2	18.6	1.6	23.3	1.9	27.9	1.4	20.5	1.7	25.1	2.0	29.8	1.5	22.4	1.8	27.0	2.1	31.7	
	platy	moderate, strong	0.0	0.0	0.0	0.0	0.0	0.0	0.0	0.0	0.0	0.0	0.0	0.0	0.0	0.0	0.0	0.0	0.0	0.0	
		prismatic, blocky, granular	weak	2.0	29.8	2.2	33.5	2.5	37.3	2.2	33.5	2.5	37.3	2.7	41.0	2.5	37.3	2.9	43.5	3.3	49.7
			moderate, strong	2.2	33.5	2.5	37.3	2.7	41.0	2.5	37.3	2.9	43.5	3.3	49.7	2.7	41.0	3.2	47.2	3.6	53.4
Clay loam, sandy clay loam, silty clay loam	massive	structureless	0.0	0.0	0.0	0.0	0.0	0.0	0.0	0.0	0.0	0.0	0.0	0.0	0.0	0.0	0.0	0.0	0.0	0.0	
		weak	0.0	0.0	0.0	0.0	0.0	0.0	0.0	0.0	0.0	0.0	0.0	0.0	0.0	0.0	0.0	0.0	0.0	0.0	
	platy	moderate, strong	0.0	0.0	0.0	0.0	0.0	0.0	0.0	0.0	0.0	0.0	0.0	0.0	0.0	0.0	0.0	0.0	0.0	0.0	
		prismatic, blocky, granular	weak	1.7	24.8	2.1	31.0	2.5	37.3	1.8	27.3	2.2	33.5	2.7	39.7	2.0	29.8	2.4	36.0	2.8	42.2
			moderate, strong	2.0	29.8	2.4	36.0	2.8	42.2	2.2	33.5	2.5	37.3	2.7	41.0	2.5	37.3	2.9	43.5	3.3	49.7
Sandy clay, silty clay, clay	massive	structureless	0.0	0.0	0.0	0.0	0.0	0.0	0.0	0.0	0.0	0.0	0.0	0.0	0.0	0.0	0.0	0.0	0.0	0.0	
		weak	0.0	0.0	0.0	0.0	0.0	0.0	0.0	0.0	0.0	0.0	0.0	0.0	0.0	0.0	0.0	0.0	0.0	0.0	
	platy	moderate, strong	0.0	0.0	0.0	0.0	0.0	0.0	0.0	0.0	0.0	0.0	0.0	0.0	0.0	0.0	0.0	0.0	0.0	0.0	
		prismatic, blocky, granular	weak	1.2	17.4	1.5	21.7	1.7	26.1	1.3	19.1	1.6	23.5	1.9	27.8	1.4	20.9	1.7	25.2	2.0	29.6
			moderate, strong	1.7	24.8	2.1	31.0	2.5	37.3	1.8	27.3	2.2	33.5	2.7	39.7	2.0	29.8	2.4	36.0	2.8	42.2

Maximum LLRs: For sites where flow of effluent away from the discharge area will be predominately vertical, to address oxygen flux use a maximum LLR of 99 to 124 L/day/m. Reduce for soils finer than well structured silt loam/silt (clay textured soils) to maximum 45 to 60 L/day/m.

**NOTES:**

Soil depth below infiltrative surface refers to the native, unsaturated soil depth. This should also represent the soils over that depth in the receiving area. Where there is variation in soil type or depth, use the lower LLR value for system design.

To be used with Daily Design Flows as determined from Section 2.2.

Ref: Tyler; Hydraulic Wastewater Loading Rates to Soil, 2001.

## **2.3.6 Site Capability and System Selection**

Certain soil and site factors are of critical importance in selecting a system, and, while the standards of Part 2 of this manual should be read together when selecting a system, Table 2-12 and Table 2-13 are provided as a summary of soil and site capability based on these critical constraining factors.

As the vertical and horizontal separation standards (Section 2.3.3) are already tabulated, they are NOT included in these tables, so a check with those standards is necessary in order to make sure they are met.

For further guidance, Part 3 Section 3.4 presents guidelines to aid selection of an onsite sewage treatment and dispersal system/technology for a site.

### **2.3.6.1 SITE CAPABILITY**

In addition to the soil and site factors in Table 2-12, the vertical and horizontal separation standards of Section 2.3.3 and other standards of this Manual should be satisfied.

Where a solution and an alternative solution are presented, either the primary OR the alternative solution can be used. In some cases this may not be possible (for example, lagoons cannot be used in all locations).

For all cases there are two further alternatives recommended under the SPM: custom design by a qualified Professional (which should include design to meet the SPM performance standards), or off-site dispersal (use of another property).

For all low permeability soil constraints the use of alternating drainfields could improve system performance.

**Table 2-12 Site Capability**

Soil type	Constraining factor	Solution	Alternative solution	Notes
Gravel and very gravelly sand (Kfs >5,000 mm/d, Perc. <1)	Very high permeability	Pressure distribution Timed dosing Type 2 10/10 or Type 3 <b>Professional design or design review by Professional strongly recommended</b>	Sand mound or sand-lined trench with Timed dosing and a minimum of 24" (61 cm) mound sand	
Gravelly sand (Kfs 2,500–3,500 mm/d, Perc. <2 min/inch)	High permeability	Pressure distribution Timed dosing	Sand mound or sand-lined trench with Timed dosing	Except where native soil vertical separation is greater than 72" (1.83 m)
Coarse to medium sand/loamy sand (Kfs 1,500–3,500 mm/d, Perc. 2–5 min/inch)	High permeability	Pressure distribution		Except where native soil vertical separation is greater than 72" (1.83 m)
Over 50% of soil is rock fragments larger than gravel, or over 60% coarse gravel (or in combination over 60% total coarse gravel and rock fragments)	Risk of effluent short circuiting due to large fractures, and severely reduced soil area for dispersal and treatment.	Pressure distribution Timed dosing Type 3	Only where vertical separation to water table is over 72" (1.83 m): 1. Sand mound or sand-lined trench with Timed dosing (and reduced basal loading rate). 2. Subsurface Drip Distribution, with Type 2 10/10	Base HLR and LLR on the non-gravel/rock portion of the soil and reduce loading rate by percentage of rock fragments/gravel. See footnote.
Loam, Silt Loam and Silt soils with platy structure of weak grade	Requires low hydraulic application rate AND unsuitable for infiltrative surface.	System or sand mound, with infiltrative surface a minimum of 18" (45 cm) above platy layer. AND Pressure distribution with low hydraulic application rate timed dosing.	For plough pan or thin layers with acceptable soils below: Remediation (where possible) OR sand-lined trenches penetrating below the layer (where suitable).	If platy structure is noted on a site, site investigation should include a minimum of 4 observation test pits in the dispersal area and two in the receiving area. Site investigation should establish that remediation has succeeded where this is used.
Sandy clay, silty clay or clay soils (with moderate or strong BK, GR or P structure) (Kfs 20–60 mm/d, Perc >60 min/inch)	Low permeability	Pressure distribution Type 2 10/10 or 3, timed dosing	Sand mound, OR Lagoon, where appropriate, OR ETA bed, where appropriate	In the majority of cases these soils will have a clay content of over 40%, see requirements below
Sandy clay, silty clay or clay soils (with weak BK, GR or P structure)	Low permeability, requires low HAR and unsuitable for infiltrative surface	System (Type 2 or 3) or Sand mound, with infiltrative surface a minimum of 18" (45 cm) above these soils AND pressure distribution with timed dosing	Lagoon, where appropriate, OR ETA bed, where appropriate	
Soil contains greater than 40% clay OR Kfs less than 20 mm/day, 120 min/inch Perc	HLR table and LLR tables should be reduced	Pressure distribution Timed dosing Type 2 10/10 or Type 3 <b>Professional design or design review by Professional strongly recommended</b>	Sand mound with Timed dosing and a minimum of 24" mound sand. <b>Professional strongly recommended</b> to establish basal HLR and LLR; OR Lagoon or ETA bed, where appropriate	Also applies where soil contains significant amounts of expandable clay minerals (smectite, vermiculite) See Appendix I
Organic soils, peat	Difficulty in establishing a suitable HLR	<b>Professional strongly recommended</b> to establish HLR and LLR		
Soils labelled as 'not recommended' in the HLR or LLR tables, or where the HLR or LLR tables show a zero	Low permeability	Pressure distribution Timed dosing Type 2 10/10 or Type 3 <b>Professional design or design review by Professional strongly recommended</b>	Sand mound with Timed dosing and a minimum of 24" mound sand. <b>Professional strongly recommended</b> to establish basal HLR and LLR; OR Lagoon, where appropriate, OR ETA bed, where appropriate	
Soils with a consistency stronger than moderately hard (dry), firm (moist), or of any cemented class	HLR table and LLRs should be reduced	<b>Professional design or design review by Professional strongly recommended</b> to establish HLR and LLR	Lagoon or ETA bed, where appropriate	See glossary
Depth of SHWT or low permeability layer less than 18" (45 cm) below surface	Low vertical separation	Pressure distribution Type 3, plus sand fill	Sand mound per SPM standards, where appropriate	See Section 2.3.3.2

*Notes:*

A material could be defined as 'rock' when over 50% of the soil is made up of rock fragments that are larger than gravel. However, certain colluvial soils in the geological process of developing from parent rock material (inceptisols, upper saprolites) could be suitable for effluent treatment and dispersal. The system design **should** address suitable loading rates and dosing regimens to prevent saturated flow occurring in the inceptisol.

Coarse gravel is defined as the portion of the soil consisting of gravel particles larger than 20 mm and up to 75 mm. Rock fragments larger than gravel are those over 75 mm in size.

With lesser amounts of rock fragments/coarse gravel, reduction of HLR should also be made in proportion to the percentage of this material. Where the percentage is less than 35% normal HLR could be used.

Where Table 2-12 and Table 2-13 state "Professional strongly recommended" in this context this recommends design or design review by a professional.

### 2.3.6.2 SITE CAPABILITY CLASSIFICATION (LIMITING CONDITIONS) FOR SPECIFIC TYPES OF SYSTEMS

Table 2-13 identifies soil and site constraints that limit the use of various types of systems, and also specific features (for example, sand depth standards for a sand mound) to address constraints.

In addition to the soil and site factors in Table 2-13, the vertical and horizontal separation standards of Section 2.3.3 and other standards of this Manual should be satisfied.

**Table 2-13 Site Capability and System Type**

System type	Soil type	Other constraint	Requirement or limit	Notes
Sand mound	Gravel and very gravelly sand or expandable clay soils		Timed dosing and a minimum of 61 cm (24") sand	
	Sand, gravelly sand soils		Minimum 61 cm (24") sand	
		Slopes over 25%	Not recommended	
		Concave slopes	Special care, see Part 3	
At grade beds		Slopes over 25%	Not recommended	
		Concave slopes	Special care, see Part 3	
Seepage beds	Other than Coarse sand, fine sand, loamy sand, silty sand or sandy loam		Not suitable	HLR reduction required (factor of 1.35)
		Slopes over 15%	Not suitable	
Gravity systems	Gravel and very gravelly sand		Not suitable	
	Gravelly sand, Coarse to medium sand/loamy sand		Only permitted where vertical separation in excess of 1.83 m (72")	
	Clay loam, sandy clay loam, silty clay loam, Sandy clay, silty clay or clay		Not suitable	
		Slope 15% or greater	Dosed serial or sequential system recommended	
		Infiltrative surface over 93 m <sup>2</sup> (1,000 ft <sup>2</sup> )	Dosed systems only	Should be per section 3.7
	Vertical separation less than 91 cm (36")	Not suitable		
Pressure systems	Gravelly sand or Coarse to medium sand/loamy sand		Horizontal setbacks increased to same as for gravity systems	Setback credit is still applicable for sand mounds/similar technology using a minimum of 24" (600 mm) sand
Alternating fields	Gravelly sand or Coarse to medium sand/loamy sand		Consider increase in vertical separation	
Type 2 systems	Gravelly sand or Coarse to medium sand/loamy sand soils		Consider increase in vertical separation where Type 2 loading rates are used	
B.C. zero discharge Lagoons	Soil percolation rate less than 60 minutes/2.5 cm (1 inch) or Kfs greater than 20 mm/day		Not suitable	
		Lots smaller than 1.62Ha (4.0 Acres)	Not suitable	
		Slope over 12%	<b>Professional strongly recommended</b>	
		Insufficient unsaturated soil depth	<b>Professional strongly recommended</b>	
	No net positive evaporation	<b>Professional strongly recommended</b>		
Evapotranspiration Absorption (ETA) bed	Soil percolation rate less than 60 minutes/2.5 cm (1 inch) or Kfs greater than 20 mm/day		<b>Professional strongly recommended</b>	
		No Annual net positive Evapotranspiration	<b>Professional strongly recommended</b>	
Evapotranspiration (ET) bed		Annual net positive Evapotranspiration less than 610 mm (24")	<b>Professional strongly recommended</b>	
All soil absorption systems		Soil moisture conditions	In all cases systems should not be constructed when soil moisture is too high, as this will damage soil structure and may lead to system failure. Cohesive soils above the plastic limit are too wet for system construction. Soil moisture should be assessed at surface, infiltrative surface level and 200 mm below infiltrative surface prior to system construction.	

### 2.3.6.3 FLOOD PLAINS

The infiltrative surface of a trench or bed system (bottom of the exfiltration trench) or the basal area of a sand mound should be 2 feet above the 1 in 20 year flood level. Tanks and treatment facilities should also be located outside of the 1 in 20 year flood level. This restriction does not apply where the land is protected from flooding by dykes.

Where no part of the lot is available for the discharge area outside of the flood plain, the system could be constructed or repaired in the 1 in 20 year flood plain; however, any vent or electrical connection should be above the 1 in 20 year flood plain and no sand mound should be constructed in the flood plain area.

Lagoon berm top elevation should be a minimum of 1' above the one in 100 year flood level.

## ***2.4 Residential Sewage and Treatment Standards***

---

In order to create standards for system design, it is necessary to define expected source and effluent standards.

Where the SPM refers to “residential sewage,” “residential strength waste” or “Type 1 effluent,” refer to Table 2-14 for definitions and effluent standards.

- Standards listed in Table 2-14 are not exhaustive. They cover only the main constituents of sewage and effluent that are of concern.
- Because research results present a range of values for the various parameters, both the ranges and recommended maximal values are presented.

In Appendix J, a suggested source control policy for inclusion with a small system maintenance plan is provided for reference.

**Table 2-14 Residential Sewage and Type 1 Effluent Standards**

Parameter	Residential Sewage INFLUENT		Type 1 effluent		Notes
	RANGE	MAXIMUM PERMITTED	EXPECTED RANGE	MAXIMUM PERMITTED	
TSS (mg/L)	100–400	350	20–55	60	
BOD <sub>5</sub> (mg/L)	100–400	300	100–140	150	
Pathogen indicator as Fecal Coliforms (coliform forming units/100 ml)	10 <sup>3</sup> –10 <sup>7</sup>		10 <sup>4</sup>		
Total Nitrogen (mg/L)	20–85		50–90		
NH <sub>3</sub> as Nitrogen (mg/L)	30–80		30–50		
Total Phosphorus (mg/L)	4–20		12–20		
Oil and Grease (mg/L)	50–150	100	10–20	20 (15)	15 mg/L for sand media filters (incl. Sand mounds and related technology)
Sodium (SAR)	1–10, avg. 3.5		5	8	Value for non sodic soils with >15% clay content. See footnote.
With elctroconductivity (microS/m) greater than or equal to			1,500 or TDS >900 mg/L	1,000 or TDS >700	
Temperature (°C)	7–18 (13–30 in warm regions)				
pH		6–9	7.1–8.3	6–9	
Peak minute flow (peaking factor to average flow)		100			Or 50 to DDF
Peak minute flow (L/min(lg/min))		70 (15.4)			For septic tank designs normally available in B.C. see note.
Peak 15 min flow (L/min(lg/min))		30 (6.6)			
Peak hour flow (peaking factor to average flow)	3–12	8			Or 4 to DDF
Peak hour flow (L/hr(lg/hr))		454 (100)			
Peak day flow (peaking factor to average flow)	1.5–3.5	2.5			
Peak month flow (peaking factor to average flow)	1.25–1.5				

*Notes:*  
 BOD and TSS maximum levels are per the NSF40 standard.

Expected ranges are based on research — largely the reports of Crites and Tchobanoglous, and Laak.

All Type 1 systems should use an effluent filter as per Part 3. Type 1 effluent range values shown are those for systems with a properly designed and installed effluent filter, based on USEPA, Crites and Tchobanoglous and upon Laak.

Allowable peak flow rates in the table are calculated for normal residential use and DDF (Daily Design Flow) up to 6 bedrooms and/or 2,500 L/day (550IG/day) DDF. Flow rates for residences larger than 6 bedrooms or DDF over 2,500 L/day (550IG/day) can be calculated based upon the peaking factors provided here. Peak 1 min., 15 min. and 1 hour flows may safely exceed the values given in the table if the septic tank or system is designed to accommodate or equalize these peaks.

Surge flows could exceed the stated one minute flows. However, the limited size of the unit being drained will prevent peak one minute flows from exceeding the level that may lead to tank scouring.

Water softener wash water and chlorinated back-wash water should not be discharged to an onsite system. Reverse osmosis flush flows should also not be discharged to the onsite system. See Appendix K.

SAR: Sodium Adsorption Ratio (SAR) and salinity, for details including discussion on water softeners, see Appendix K.

Excess disinfectants and chemicals will affect the biological processes as can specific toxic substances from site activities. Examples of disinfectants and chemicals are: photographic chemicals, weed killers, motor oils, antibiotics, floor waxes and strippers, etc. These chemicals and similar substances should be excluded from influent wastes.

Floor drains should not be connected to the onsite system.

## 2.4.1 Levels of Treatment

The Sewerage System Regulation and the Standard Practice Manual are structured around specific levels of treatment (pre-treatment) before discharge into the ground.

### 2.4.1.1 EFFLUENT TYPES DEFINED IN THE REGULATION

The Sewerage System Regulation defines three types of effluent, Type 1, 2 and 3.

- Type 1 is treatment by septic tank, see Table 2-14 for Type 1 effluent quality
- Type 2 is treatment that produces an effluent consistently containing less than 45 mg/L of total suspended solids and having a five day biochemical oxygen demand (BOD<sub>5</sub>) of less than 45 mg/L.
- Type 3 is treatment that produces an effluent consistently containing less than 10 mg/L of total suspended solids and having a five day biochemical oxygen demand (BOD<sub>5</sub>) of less than 10 mg/L, and a median fecal coliform density of less than 400 Colony Forming Units (cfu) per 100 mL.

#### NOTES:

The Regulation identifies Type1, Type 2 and Type 3 effluent.

Type 1 effluent is equivalent to Municipal Sewage Regulation (MSR) Class D effluent; the SPM highly recommends Type 1 treatment to include use of an effluent filter.

Type 2 effluent is equivalent to MSR Class C effluent.

MSR Class B effluent is a form of Type 2 effluent with 10/10 characteristics (see Type 2 10/10, below).

Type 3 effluent is equivalent to MSR Class B effluent with coliform monitoring.

APs should note that:

- Where chlorine or other persistent chemicals are used as disinfectants, the chemicals should be removed before the effluent is discharged. (Maximum residual level 4.0 mg/L as Cl<sub>2</sub>).
- Where sodium levels in effluent are raised because chemicals that disinfect are used (e.g., Sodium Hypochlorite), effluent SAR should be maintained at levels that will not cause long-term damage to receiving soils.

#### 2.4.1.2 ADDITIONAL TREATMENT

The AP can define additional treatment needs for an onsite system.

##### *Type 2 10/10 Effluent*

Type 2 effluent is of minimum 45/45 standard. With certain technologies, a Type 2 treatment facility that produces an effluent consistently containing less than 10 mg/L of total suspended solids and having a five day biochemical oxygen demand (BOD<sub>5</sub>) of less than 10 mg/L, is needed.

In the Standard Practice Manual, this is termed Type 2 10/10 effluent. Where “Type 2 10/10” effluent is referred to, the HLR is the same as for Type 2 effluent.

If Type 2 10/10 effluent is used in a system design, the filing should report the effluent type as Type 2 effluent.

#### **2.4.2 Monitoring for Treatment Facilities and Discharge Area**

The quantity and quality of effluent is critically important to dispersal area performance, and so procedures to effectively monitor effluent quantity and quality are strongly recommended. The discharge area itself should also be regularly monitored for proper operation:

- the design and the maintenance plan should include provision for monitoring of flows and, for Type 2 and 3 systems, regular monitoring of effluent quality;
- provide for regular inspection of the system, including the discharge area, for proper operation;
- in order to confirm that the effluent is being treated and that the system operates within expected performance levels, the system should have a defined point from which an effluent sample could be easily taken; and,
- the design should address monitoring needs through appropriate access, sample ports, flow recording metres or pump cycle counters, datalogging, etc.

Where a system is needed to treat high-strength waste or where nutrient reduction is needed before the effluent is discharged, then more detailed monitoring should be included in the sewerage system maintenance plan.

The sewerage system’s maintenance plan should be written so that design performance is assured, effective monitoring is in place, and appropriate actions are taken when performance standards are not met.

## Part 3

# Technologies for Onsite Systems: Selection, Design, Installation and Specification Standards and Guidelines

### ***3.1 Base Performance Standards***

---

Performance standards for onsite sewage systems consist, at the most fundamental level, of ensuring that the system as designed, installed and operated does not contribute to the creation of a health hazard.

Part 3 presents “significant standards and guidelines” which reflect the current state of standard practice in support of this base performance standard.

Where possible the significant standards and guidelines presented here are supported by peer reviewed research as well as by industry practice. These standards also take into account the practicality and economics of onsite sewage treatment and disposal.

Part 3 “significant standards and guidelines” include important standards and guidelines for onsite technologies and offer best practices for the design, filing, construction and maintenance of sewerage systems appropriate for use in B.C . These significant standards are good indicators of

- whether an AP will be meeting “standard practice” as is required by the SSR and/or
- whether the system as designed, installed and operated will not cause or contribute to the creation of a health hazard

It is ***recommended*** that these significant standards and guidelines be followed by all APs (professionals and registered practitioners) and that ***any deviation*** from ***any*** of these significant standards:

- be supported by reference to authoritative sources relevant to the climate and soil of the areas in which the system will be used; and
- be made only with the AP’s assurance that the resulting system will function within the environment at an equal or better performance level as would have been provided by the SPM standard or guideline.

It is also recommended that wherever ***explicitly identified in Part 3*** of the SPM, deviation from the Part 3 significant standards or guidelines should only be made by an AP that meets specific qualifications (e.g., ***is a professional***, groundwater hydrologist, etc.).

### 3.1.1 LINKED STANDARDS

In certain cases a standard is made up of linked steps that should be followed in order to properly meet the overall recommended standard.

For example, when the SPM states that the HLR tables “must” or “should” be used with the SPM Daily Design Flows, it is making it clear that if these steps are not linked malfunction of the system may result. Therefore where a standard is identified as linked in the manual; it is ***highly recommended*** that all standards are followed.

Part 2 critical standards are considered to be linked standards. In addition, where a “critical standard” in Part 2 is comprised of linked steps and includes linkage to the “significant standards” of Part 3 of this Part the manual in Part 2 will indicate this.

The application of Part 3 significant standards are linked to use of the Part 2 critical standards as provided in this manual and discussed above.

Also, in Part 3 the significant standards provided for each technology are considered to be linked. Where the standard for a technology is linked to that for another technology, the manual in Part 3 will indicate this.

## 3.2 *Organization of Part 3*

---

- Base performance standards;
- General standards for design, installation and maintenance;
- Site constraints and process selection,
  - to aid selection of appropriate techniques for a site;
- Technologies:
  - These are a “toolbox” of techniques available for onsite systems;
  - The technologies covered in Part 3 are divided into:
    - Connection to the Onsite System — Piping (*Section 3.5*)
    - Treatment Facilities (*Section 3.6*)
    - Subsurface Wastewater Infiltration Systems (SWIS) (*Section 3.7*)
    - Media filters with integrated SWIS (including sand mounds and sand-lined trenches) (*Section 3.8*)
    - Evapotranspiration/Absorption (ETA) and Evapotranspiration (ET) Beds (*Section 3.9*)
    - Lagoons (*Section 3.10*)
  - Each of these sections is organized with the following headings:
    - Performance Standards
    - Description and Principles of Operation
    - Design Considerations

- Specifications and Installation Considerations
- Maintenance and Monitoring Considerations

In some cases one or more headings are not used; and,

### ***3.3 Minimum Design, Installation, Maintenance and Monitoring Standards***

---

Further to the base roles and responsibilities stated in Part 1, Section 1.3, Section 3.3 sets out minimum standards for onsite system design, installation, maintenance and monitoring.

#### **3.3.1 Planning (Design)**

In Part 3 of the manual each technology includes descriptions of the critical design considerations for that technology. When a design is filed, how those considerations were addressed should be recorded in the record of design. For example, for a pressure distribution system this would include such items as pump chamber sizing, dose and reserve volumes, orifice diameter, etc.

Design documents should include enough information that an Authorized Person of equal knowledge/skill level can understand the design concept and application, and should provide the information needed for installation of the design.

In addition, all designs as filed should include at a minimum:

- site investigation record as per Section 2.3.2;
- any covenants or easements that could affect the onsite system;
- location and description of horizontal setbacks, for example, wells — which could include such items as confined or unconfined aquifer, projected pumping rate, depth, current condition of water quality;
- choice of site location used, including choice of soil type for loading rate selection and constraint classification;
- a clear description of the design process, including the logic for choice of process and SWIS (Subsurface Wastewater Infiltration System) based upon the site investigation results and owner's needs;
- any supporting references used for the design;
- Daily Design Flow, Average Daily Flow, Linear and Hydraulic Loading Rates,
  - how Daily Design Flow was calculated;
  - dosing regimen, if dosing is used;
  - owner's written acknowledgement of proposed use and flow as per Part 2;

- how vertical and horizontal separation are addressed, including any increases beyond the minimums in Part 2;
- any necessary treatment to influent sewage to ensure peak flows or quality meets residential standards;
- sizing and specification of pre treatment process (example septic tank and effluent filter);
- site and soil impact considerations;
- any covenants or easements that need to be registered in order for the system to be installed;
- sizing and specifications for the SWIS, including system parameters and calculations used by the AP to arrive at the component sizing and flow distribution shown in the design;
- a site plan; and,
- AP seal.

A design could also include information on the skills needed to install the specific system, and notes on points where the planner or designer should be consulted or should inspect during installation.

If another source of standard practice is applied, references should be included.

APs are encouraged to use checklists to assist in inclusion of all necessary items in the documents and plans.

### 3.3.1.1 SITE PLANS

Site plans should be drawn to provide sufficient information to support an understanding of the system design and specifications. Clarity is important and often a simple plan is sufficient, much information is better conveyed as part of the site investigation record/design notes/specifications/as built specifications.

As a minimum, plans should:

- be drawn to scale;
  - this should include a scale bar;
  - preferred scales are, 1:100, 1:125, 1:150, 1:200, 1:250, 1:300, 1:400, 1:500, 1:600, 1:750 or 1:900, or multiples by 10 of these;
  - scale should show the system or detail at the smallest size that gives enough information. This is so that any dimension that needs to be scaled off can be measured to suitable accuracy (1:500 is normal for the system layout drawing). Where this cannot be achieved, dimensions should be shown or detail drawings added;
  - where a detail is not to scale, this should be shown (as “N.T.S.”);
- be oriented to true north meridian;

- be reproducible in black and white;
- be on 8.5 × 11, 8.5 × 14 or 11 × 17 paper where possible;
- have lettering that is readable (minimum 2 mm height);
- include a title block with such information as:
  - project name, lot legal description and PID;
  - location address;
  - drawing number and drawing name;
  - who the plan was drawn by, drawing or revision number and/or date;
  - scale and dimension system, benchmarks; and,
  - reference to the correctly named and dated site investigation record, design notes and specifications;
- show the property lines and lot location (this could be by key plan) to a level of detail sufficient to locate the system on the lot;
- show key features for system design, including those for critical horizontal setbacks (these could be on the lot or outside the lot), such as:
  - wells, water sources, water bodies, water lines (including planned);
  - breakouts, drains, buildings and structures, retaining walls (including planned);
  - access, paths and driveways (including planned);
  - easements and covenants, existing and planned, where relevant;
  - soil investigation test pits and permeability test locations;
  - discharge area, receiving area, existing and planned;
  - pre-treatment facility and transport lines, existing and planned; and,
  - onsite system components, which could require use of detail drawings where these would not otherwise be clear from the plan or specifications.
- show critical setbacks that may be shown on plan as a broken line where they are relevant to design:
  - dimensions need not be added to scale drawings where the scale renders them unnecessary;
  - parts of the setback information could also be covered by notes;
- show information to support an understanding of the site, site soils, site drainage and site topography;
  - this could be by contour plan and/or by slope direction and description (arrows, percentage and slope shape/location);
  - banks, bluffs and depressions where relevant to the design;
  - drainage courses, wet areas, this should include vegetation types if relevant;
  - where possible critical elevations, example building sewer; and,
- include an AP seal.

### **3.3.2 Installation**

Installation should address, at a minimum, substantial compliance with the design. Where this is not possible, the AP should be consulted and necessary redesign or adjustments to specifications should be made.

In Part 3 of the manual, each technology includes descriptions of the critical installation considerations for that technology. These should be addressed during installation. For example, for a sand mound system this would include such items as site preparation, basal area scarification, etc.

#### **3.3.2.1 POST INSTALLATION CERTIFICATION**

Within 30 days after installation, the planner or designer submits a Letter of Certification certifying compliance with the Sewerage System Regulation to the Health Authority.

This should be accompanied by:

- the as built specifications, which should include all specifications per the design plus a record of how any changes were made, specifications of as installed equipment, and commissioning details;
- an accurate, scaled, record drawing which should include sufficient detail to permit location of key system components at a later date, as well as to support an understanding of the systems and any modifications to the original design. This plan should meet the relevant standards for the site plan (above);
- installer's letter of certification;
- a written acknowledgement by the owners that the system should only be used within the allowable average and Daily Design Flows and that they will observe the source control policy in the system maintenance plan;
- a maintenance plan as per Part 3, Section 3.3.3.4, and;
- AP seal.

APs are encouraged to use checklists to assist in inclusion of all necessary items in the documents and plans

### **3.3.3 Maintenance and Monitoring**

In Part 3 of the manual each technology includes descriptions of the critical maintenance and monitoring considerations for that technology. These should be addressed during maintenance and monitoring and in the maintenance plan. For example, for a gravity distribution system this would include such items as monitoring of observation ports, d-box, etc.

This section addresses general maintenance and monitoring considerations for all techniques and for the system as a whole, including recommended minimum standards for a maintenance plan.

### 3.3.3.1 ROLES AND RESPONSIBILITIES

#### *Owner*

Section 10 of the Sewerage System Regulation requires that an owner ensures that a sewerage system on the owner's land is maintained in accordance with the maintenance plan provided for the sewerage system.

In addition the owner must keep records of maintenance carried out according to the maintenance plan.

Section 12 of the Regulation indicates that a person commits an offence if the person maintains a sewerage system without proper qualifications, i.e., without being an Authorized Person.

#### *Planner and Installer*

The Authorized Person must prepare a maintenance plan for the owner/operator (SSR Section 9).

The maintenance plan must be submitted with the letter of certification, which indicates that if operated and maintained as set out in the maintenance plan, the sewerage system will not cause or contribute to a health hazard (SSR Section 9).

Under section 10(3) of the SSR, an Authorized Person who makes a repair or alteration to a sewerage system must provide the owner with an amendment to the maintenance plan if:

- the work is not already covered by the existing maintenance plan in the filing of the sewerage system with the Health Authority; and,
- the maintenance plan in the filing is, if followed, no longer sufficient to ensure that the sewerage system does not cause, or contribute to, a health hazard.

### 3.3.3.2 MAINTENANCE PROVIDER (MP)

Section 12 of the Regulation indicates that a person commits an offence if the person maintains a sewerage system without proper qualifications, i.e., without being an Authorized Person.

The Maintenance Provider should use methods of assessing, reporting and cleaning as described or reviewed in current BCOSSA approved maintenance provider certification courses. (*See Appendix L.*)

The Maintenance Provider should assist the landowner by:

- observing and documenting the physical condition and performance of the entire system and not just selected portions;
- determining if any Performance Malfunction, Health or Safety Hazard, or any other issues may be present;

- reviewing the owner's current and expected usage and comparing the system's plan/design and current condition to the current usage;
- ensuring that a suitable maintenance plan is in place, that the owner understands their responsibilities and how to follow the plan;
- carrying out any maintenance and repairs as is necessary for proper operation;
- managing the maintenance and monitoring of the entire onsite system. MPs could utilize the services of others, such as electricians, tank cleaning services and service technicians for system components if needed. However, the MP is ultimately the one ensuring all aspects of maintenance and monitoring are achieved; and,
- education of the homeowner or users as required.

Following each visit, the MP should provide the client with a written report that includes, at a minimum:

- the date maintenance and monitoring was carried out, a file or reference number, the name of the client/owner, the address of the site, and MP's seal with signature;
- an evaluation of the system's filing document, maintenance plan or original permit information in relation to the actual system found and the current usage;
- a general description of the type and components of the system that summarize what was located and tested as well as anything that was not located or tested and explain the reason why it was not;
- an evaluation of the system's current performance summarizing the results of the testing in an easy to understand way;
- a listing of required repairs and/or recommended improvements. This gives the owner a list of what problems were found, how minor or serious these are, how soon these should or need to be corrected, and the reason why it should or needs to be done; and,
- AP seal.

### 3.3.3.3 DESIGN AND INSTALLATION FOR MONITORING

All systems should have a defined point from which an effluent sample can be readily obtained in order to confirm that the operation of the system is within the expected performance required of that system. A grab-sample point from the nearest point to the outlet of a septic tank (for Type 1), grease interceptor, treatment plant or process (for Type 2), or immediately following any disinfection equipment (for Type 3) should allow ready access by any Maintenance Provider or other Authorized Person to carry out such sampling.

The inlet pipe to a pump chamber is an ideal point from which freely flowing effluent can be collected using simple gathering equipment and designs/installations should make this sample point accessible at all times.

### 3.3.3.4 MAINTENANCE PLAN

Section 9(1) (a) (ii) requires that an authorized person must provide the owner of a system with a maintenance plan for the sewerage system that is consistent with standard practice. Section 9(2) states that an authorized person may have regard to the SPM to determine whether the maintenance plan is consistent with standard practice.

Consequently an AP should prepare the maintenance plan (Operation and Maintenance plan or OM Plan) to provide the user/operator and the maintenance provider with the information about the system necessary to operate and maintain it. The user/operator and the maintenance provider should be able to follow the line of reasoning used when the system was designed.

The maintenance plan should include design and measured performance data for equipment installed this will include such items as: squirt heights, timer settings, pump tank draw-down depths, mm per Litre (or inches per U.S. gallon) for the pump tank and actual pump delivery (L/min or U.S. gallons/min).

Part 3 includes key maintenance or monitoring tasks for each technology, these points are not exhaustive, and the maintenance plan should be prepared to address the actual system as designed per site, including operation and maintenance tasks that ensure the system will perform as designed.

The maintenance plan should explain the assumptions made to establish the design parameters and should include, at a minimum, the following:

- operation manual for the system and for subsystems (for example, a treatment plant),
  - clear instructions which pull any subsystem manuals together to form a comprehensive manual for system operation,
  - description/instructions for monitoring sample collection,
  - data to be recorded at intervals and how that data will be collected. For example, flow data collection or squirt height measurement,
  - guidance on appropriate monitoring/maintenance schedules, quality assurance and troubleshooting,
- description of the system, including record drawing and as installed specifications;
- warranties and manufacturer information for all relevant equipment;
- explanation of general system function, operational expectations, owner responsibility, maintenance provider qualifications/skills required;
- monitoring plan, including actions for use of the monitoring data,
  - This should include provisions for flow monitoring;
- a quick reference sheet, including simplified flow chart of the system, operation instructions and contact information,

- Including reference to the original maintenance plan and contact information for the Health Authority with instructions on how to obtain a copy of the full maintenance plan from them;
- table of maintenance tasks and schedule with blank forms for recording monitoring and maintenance;
- process for maintenance plan review, including a review period and when it is necessary to consult a planner/designer, this could also include a process for triggering a review based upon monitoring data or particular types of system malfunction;
- An easy-to-understand list of system “Dos and Don’ts”;
- a source control policy which should include:
  - allowable influent quality, for a residential system. This could be based upon the standards for residential sewage in Part 2 of the SPM,
  - allowable influent flows. This should include average and daily design flow as well as allowable peak flows. For smaller systems, the standards for residential sewage in Part 2 provide suitable peak flows;
- a list of relevant contacts related to system components and ongoing operations;
- emergency and redundancy provisions, including an emergency number to call;
- equipment and parts supply, a list of parts to be held on site, and sources of parts; and,
- troubleshooting information for common operational problems that might occur. This information should be as detailed and complete as needed to assist the maintenance provider and owner to correct malfunctions.

### *Notice to Occupant*

The AP should place in a prominent location (in the building served or in the mechanical room for the system) a plastic laminated notice that includes:

- maintenance plan quick reference sheet (as above);
- summary maintenance schedule table (as above);
- summary of system “dos and don’ts”; and,
- make, model and serial numbers of all mechanical components and commissioning details pumps/dispersal field.

### 3.3.3.5 FREQUENCY OF MONITORING AND MAINTENANCE

The frequency for monitoring and maintenance of treatment and dispersal systems depends on of the level of treatment and upon the design.

See Table 3-1 below for monitoring interval guidelines.

Sewerage system monitoring levels should be increased:

- when the planner or designer determines that more monitoring is needed; and/or,
- when the system is installed on a site with very severe constraints. Then minimum semi-annual inspections are strongly recommended.

**Table 3-1 Minimum Monitoring Intervals**

Effluent type	Inspection (by maintenance provider)	Flow	BOD and TSS	Fecal Coliforms	Notes
1	Bi-annual	Bi-Annual			BOD/TSS only for diagnosis
2	Annual	Annual	Annual		6 Mo for first year
3	Semi-annual	Semi-annual	Semi-annual	Semi-annual	
Lagoon	Bi-annual				Flow monitoring for diagnosis only

**NOTES:**  
 For dosing or pressure distribution systems, flow data from pump or siphon run/cycle counters will provide average flow.

Where a trickling type gravity system is used, an approximate record of flows could be made by using a water meter on the household supply (with a bypass for flows that do not go to the system). Flow monitoring could also be made using a datalogger with tipping d-box or flow recording meter. If necessary, where house plumbing is not complete at time of certification of the system, this requirement could be included in the maintenance plan and to be the responsibility of the owner.

Flow data is most useful when recorded with a time/date stamp, giving daily or hourly resolution. This is strongly recommended in all cases.

The collection of samples should conform with standard procedures contained in the British Columbia Field Sampling Manual, or to the standard methods for the examination of water and wastewater.

An analysis should be carried out by a certified laboratory.

If the sample does not meet standards, an action should be triggered. For example, immediately resample at 1 Mo interval until consistent (>90% of samples are compliant); sample at 6 month interval for next year.

Monitoring samples collected for process management could be analysed by a competent maintenance provider as long as the minimum number of samples are analysed by a certified laboratory.

Where higher than Type 2 or Type 3 effluent standard is recommended, then the standard that has been designed for the sewerage system should be maintained.

See the sections of Part 3 for monitoring recommendations for particular technologies.

The maintenance plan should specify that systems be monitored and maintained at a frequency commensurate with the site, soil, system complexity and use patterns. This could mean a higher frequency than the minimums set out in Part 2. This should be clearly stated in the maintenance plan and the owner should be made aware of the needed intervals.

Where there is a complaint or malfunction, this could also trigger a monitoring and maintenance visit.

Septic tanks need to be pumped regularly to ensure proper functioning. If the septic system is not pumped in a timely manner, solids will build up, bypass the effluent tee or baffle and clog the soil absorption system — eventually resulting in hydraulic overload (i.e., plumbing backup and wastewater appearing on the ground surface). See Section 3.6.1.5 for expected pump out intervals. The maintenance plan should include provision for monitoring and maintenance of the septic tank.

Effluent filters will need to be maintained prior to the septic tank needing to be pumped. The system maintenance plan should indicate suitable maintenance intervals for all components including the effluent filter. It is recommended that in order to address individual use patterns, effluent filters be checked at half normal intervals for the first year to establish a guide for future cleaning intervals for that system.

A Maintenance Provider should obtain an effluent sample for testing BOD/TSS levels:

- as deemed necessary for a Type 1 system when evidence of potentially high levels could be noted at points through the system;
- as set out in the maintenance plan; or,
- at any time the Maintenance Provider has concerns about system performance.

The Maintenance Provider should carry out any other forms of testing, including metal, mineral and chemical analysis, on effluent, influent or even the potable water supply if prudent in the determination of problems with the performance of a system.

#### MONITORING:

Monitoring should include, in addition to the specific items needed for a particular system, general system assessment, including:

- record of flows, including pump starts and run time (if applicable) — analyse records to check system flows and flow patterns in relation to allowable flows as defined in the maintenance plan;
- type of use and relationship to original design;
- problems relating to original installation, example orientation of sand mound to slope, compaction of basal area;
- nuisance factors, such as odours or user complaints;
- mechanical malfunction within the component including problems with valves or other mechanical or plumbing components;
- notation of electrical connection problems such as corrosion, loose connections, exposed wiring, excessive moisture that could create arcing (where applicable);
- confirmation of alarm function and/or operation (where applicable);

- material fatigue or failure, including durability or corrosion as related to construction or structural design; and,
- neglect or improper use, such as overloading the design flow, poor maintenance of vegetative cover, inappropriate cover over the SWIS, or inappropriate activity over or in the dispersal system and the receiving area.

### **3.3.4 Safety**

It is necessary to follow all occupational health and safety requirements as applicable when working on the onsite system. These requirements include confined space entry, trenching and shoring, electrical hazards, or any other conditions as set out by WorkSafeBC, the B.C. Safety Authority or other agency.

## ***3.4 Site Capability and Process Selection***

---

In addition to the critical soil/site capability tables from Part 2 Section 2.3.6, AND the vertical and horizontal separation standards of Part 2 (Section 2.3.3) other site and soil constraints and possible solutions are listed in this section.

### **3.4.1 Site Capability — Matching Techniques to the Site**

This section is arranged under the following constraint headings:

- Vertical separation
- Horizontal separation
- Soil coarse fragment content
- Type of limiting layer
- Slope
- Available area
- Climate
- Location and type of use
- Combined constraints

#### **3.4.1.1 VERTICAL SEPARATION**

For dispersal system options based upon soil depth, see Figure 3-1. In order to address vertical separation standards (see Part 2 Section 2.3.3), trench and bed systems can be installed:

- Subsurface

- Shallow
- At grade
- Raised above grade on C33 sand fill

The following Figure 3-1 demonstrates system selection in relation to soil depth.

**Figure 3-1 System Selection in Relation to Soil Depth**

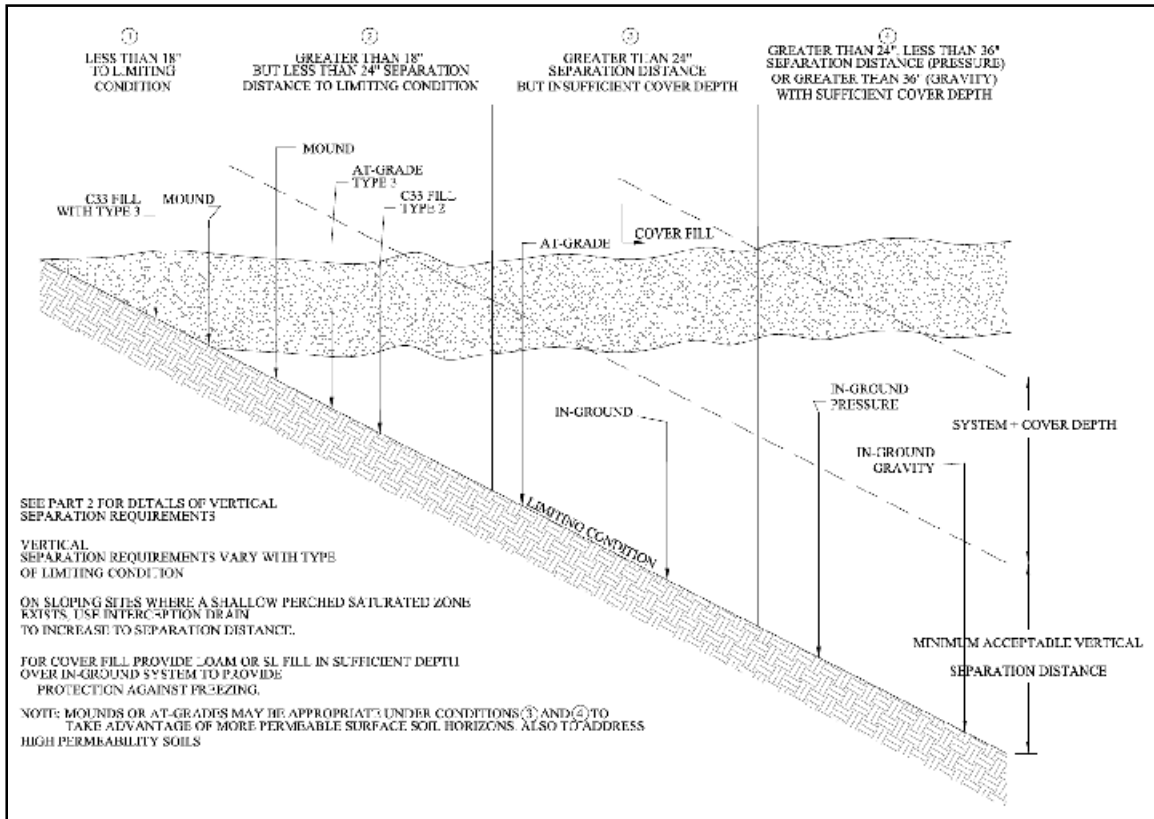

Frost considerations affect cover depth; however, this should be kept as shallow as possible.

Seepage beds should be used only in areas with high evaporation rates or when available area is limited.

Vertical separation in native soil also affects the level of treatment and dispersal used, with Type 2 and 3 needing less native soil than Type 1, and gravity needing more than pressure distribution.

Where vertical separation is shallow, or is very shallow in relation to seasonal water table or an impermeable layer, a sand mound could be suitable.

Where shallow vertical separation to water table or site drainage is an issue, the use of an interception drain or relief drains could be a possible solution.

### 3.4.1.2 HORIZONTAL SEPARATION

See Part 2 Section 2.3.3 horizontal setbacks.

Pressurized distribution will permit reduction of horizontal setbacks except for in gravelly sand or coarse to medium sand/loamy sand soils.

Where the constraint is severe, Type 3 treatment will be needed in order to obtain Type 3 horizontal setbacks. Under section 6 of the SSR type 3 treatment requires a professional.

Where the constraint is very severe, a Professional with competence in the field of hydrogeology or geotechnical engineering should be consulted to consider setback reduction below the standards, but only based upon performance monitoring, see Part 2 critical standards.

### 3.4.1.3 SOIL COARSE FRAGMENT CONTENT

In general, where the soil contains a high proportion of coarse fragments it is recommended that the HLR and LLR be based on the finer soil portion (per section 2.3.6), in addition it is recommended that the loading rate be reduced to compensate for the reduction in available soil where the proportion of coarse fragments exceeds 35%.

Certain colluvial or residual soils in the geological process of developing from parent rock material (inceptisols, upper saptrolites) could be suitable for effluent treatment and dispersal. But the system design should address suitable loading rates and dosing regimens (hydraulic application rate) to prevent saturated flow occurring in the inceptisol.

If necessary, consult a qualified Professional for design or design review.

### 3.4.1.4 TYPE OF LIMITING LAYER

#### *For Linear Loading Rate/Effluent Flow*

When determining the path of effluent flow away from the discharge area, it is considered, and whether all or part of the flow may be vertical into that layer (for example, fractured bedrock), or whether the flow will be mainly horizontal (for example, a clay layer).

See Figure 2-2 and Figure 2-3 in Part 2 Section 2.3.5 (Soil Linear Loading Rate).

#### *For Vertical Separation*

Where considering placement of a sand mound or where considering whether an increase in vertical separation should be made, the type of limiting layer is also an important consideration. The following is in order of increasing severity of the constraint:

- Impermeable barrier
- Seasonal high water table
- Fractured bedrock with soil filled crevices (coarser soils)

- Fractured bedrock
- Seasonal low water table

See sand mound vertical separation Table 2-5, Part 2 Section 2.3.3.

### 3.4.1.5 SLOPE

#### *Low Slopes*

Very low slopes (less than 3%); particularly in footslope or toe slope locations could indicate that an increase in vertical separation is needed to address potential water table mounding. This is particularly critical as the soil depth decreases and as soil permeability decreases.

#### *Steep Slopes*

- Steep slopes are a greater problem when combined with shallow soils over a low permeability layer, as this could lead to effluent breakout — this is especially likely where the soil gets shallower downslope of the discharge area. In this case careful site investigation of the receiving area and protection of that area is recommended.
  - Where slope is steep and the effluent flow will be primarily horizontal in a thin soil layer, danger of breakout should be addressed.
- Steep slopes also make construction difficult and may lead to excessive cover on the upslope edge of a bed or trench, so some systems should not be used on steeper slopes (see Section 2.3.6, Site Capability Table 2-13).
- With gravity systems, steeper slopes are better served with a dosed system using serial or sequential trenches (Distribution Box systems should not be used for slopes of 15% or greater).
- Steep slopes (over 30%) could be addressed by use of appropriate distribution technology, for example: Subsurface Drip Dispersal or Pressurized Shallow Narrow Drainfields, utilizing highly treated effluent. In order to reduce site impact. Due to micro dosing and high quality effluent, the risk of breakout is reduced.
- Very steep slopes (up to 100%) could be addressed by use of Subsurface Drip, utilizing highly treated effluent; however, particular care is needed.

#### *Slope Shape and Location*

Slope shape and location of the system on the slope are also important.

As the concavity of the slope (from side to side) increases, the use of the site is restricted and loading rates should be adjusted.

The worst situation is where the slope is concave in both the up and down and side to side directions, as this will concentrate flows and reduce the LLR. Where this is severe, the site may not be suitable.

Toe slope and footslope areas tend to receive flows from uphill and so could need interception drains.

Summit slope areas may be wet or seasonally wet.

These concerns are less important where effluent flow will be primarily vertical.

See Glossary (Appendix A) for diagrams showing slope shape and location naming conventions.

See sand mound Section 3.8 for assessment of concave slopes.

#### 3.4.1.6 AVAILABLE AREA

Where there is an area constraint, the use of Type 2 or 3 treatment could be necessary to fit the system in.

Contour length constraints may be found on narrow lots with shallow soils.

- Where LLR standards cannot be met due to site shape; drainage strategies, low Hydraulic Application Rate (timed dosing), toe blankets or a mounding study (recommended that this be by a Professional) are some of the possible approaches. See the LLR section of Part 2 (2.3.5).
- Since sand mound technology should have use of LLR in all cases, and should use a large area, small lot sizes could be particularly difficult with this technique.

#### 3.4.1.7 CLIMATE

Where freezing conditions or heavy rainfall are expected, then system design should take this into account and some techniques will be less suitable than others.

The Hydraulic and Linear Loading rate tables are based on typical B.C. climatic conditions. In very cold climates or where rainfall is very high, consider reducing loading rates accordingly. For example, use a factor of 10 to 25%.

In areas with very high rainfall, consider an increase in vertical separation and techniques to reduce flow concentration.

Where infiltrative surface should be deep in the soil profile to address freezing, consider measures to improve aeration and/or increase vertical separation and/or reduce HLR.

Lagoons and ETA or ET beds need a climate with net positive evaporation (i.e., more evaporation than rainfall). For ETA and ET beds this applies not just to the general climate of the area, but could also apply to the microclimate of the site.

#### 3.4.1.8 LOCATION AND TYPE OF USE

Some techniques may not suit certain uses (such as seasonal use) or locations (such as no available power). Where the site is very remote, cost of service is an issue. Treatment systems that need specialized maintenance should not be used where this maintenance is not readily available.

#### 3.4.1.9 COMBINED CONSTRAINTS

Where constraints are combined, it is necessary to select the strategy based on all the constraints.

For example, a 30% slope could be problematic for a sand mound, or Pressurized Shallow Narrow Drainfields may not suit extreme freezing conditions.

In Part 3, each technology listing includes design considerations which will assist in this choice.

## Technologies

### ***3.5 Connection to the Onsite System — Piping***

---

#### 3.5.1.1 CONNECTIONS AND PIPING PERFORMANCE STANDARDS

Connections to onsite systems and piping used in the onsite system should be designed to avoid creating a health hazard. Systems should be installed to be watertight and to minimize access by flies or other vectors to avoid the spread of disease. To avoid overflows, pumped systems should include designed reserve for equipment failure or power outages, as well as suitable alarms.

Venting should control odour.

In addition to the above, piping and sewage collection systems should be installed to prevent infiltration of water to the system, which may cause hydraulic overload.

#### 3.5.1.2 CONNECTIONS AND PIPING DESCRIPTION AND PRINCIPLES OF OPERATION

The wastewaters generated in the residence or from small commercial and institutional activities are collected and transported by the plumbing system drain pipes directly from the building into a septic tank or treatment plant.

Most onsite systems serve a single source of sewage, and this is transferred from the house to the system by a gravity sewer or/and an ejector pump.

Sewage ejector pumps are commonly installed where gravity flow to the septic tank is not practicable. The raw wastewater ejector pump and transfer tank is used to convey raw wastewater from the facility to a septic tank where primary treatment can occur (see Figure 3-2). Grinder pumps may also be installed for this purpose, but are less desirable (Figure 3-3). Care should be taken with pumped systems to avoid or mitigate the impact on the septic tank settling process from high peak flows (pump inflow).

In some cases, several locations can be served by a central septic tank or treatment plant. The collection system to that central facility can be simple gravity sewer piping, or can consist of pumped sewage or effluent conveyed in a pressurized forcemain.

#### ***Collection systems***

Where the system serves more than one source, a collection system is used to bring the sewage or effluent to the central facility.

These could include:

- gravity sewers;

- Small Diameter Variable Slope Sewers conveying filtered effluent in small diameter gravity sewers from individual septic tanks with effluent filters, known as a Septic Tank Effluent Gravity (STEG) system;
- Septic Tank Effluent Pump (STEP), where each house or point of use has a septic tank with effluent filter followed by a pump tank with pump discharging to a pressurized collector main;
- Septic Tank Grinder Pump (GP), similar to a STEP system but with a grinder pump discharging ground sewage to the pressurized collector main; and,
- vacuum systems.

STEG or STEP systems are commonly used to serve small cluster developments, and may often be installed at lower cost than conventional gravity sewer systems. As with raw sewage conveyance pumps, dose volumes in a STEP system should be adjusted to prevent negative impacts on pre-treatment facilities.

Grinder pump systems are commonly used in municipal applications; however, these systems are less suitable with onsite septic tanks, since the high fine TSS created impacts the effectiveness of the settling process.

Figure 3-2 Diagram: STEP System Schematic Plan and Individual Connection

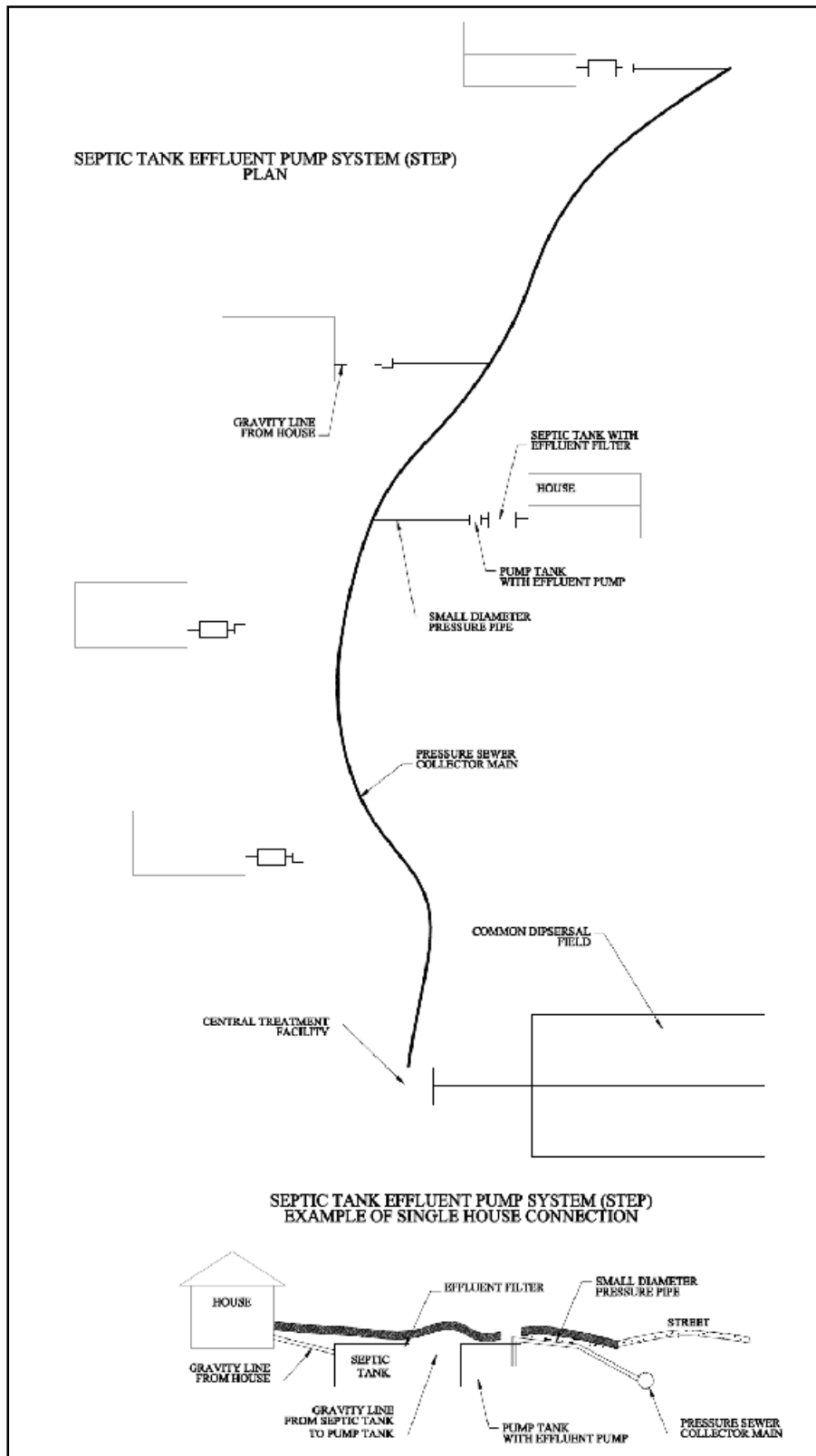
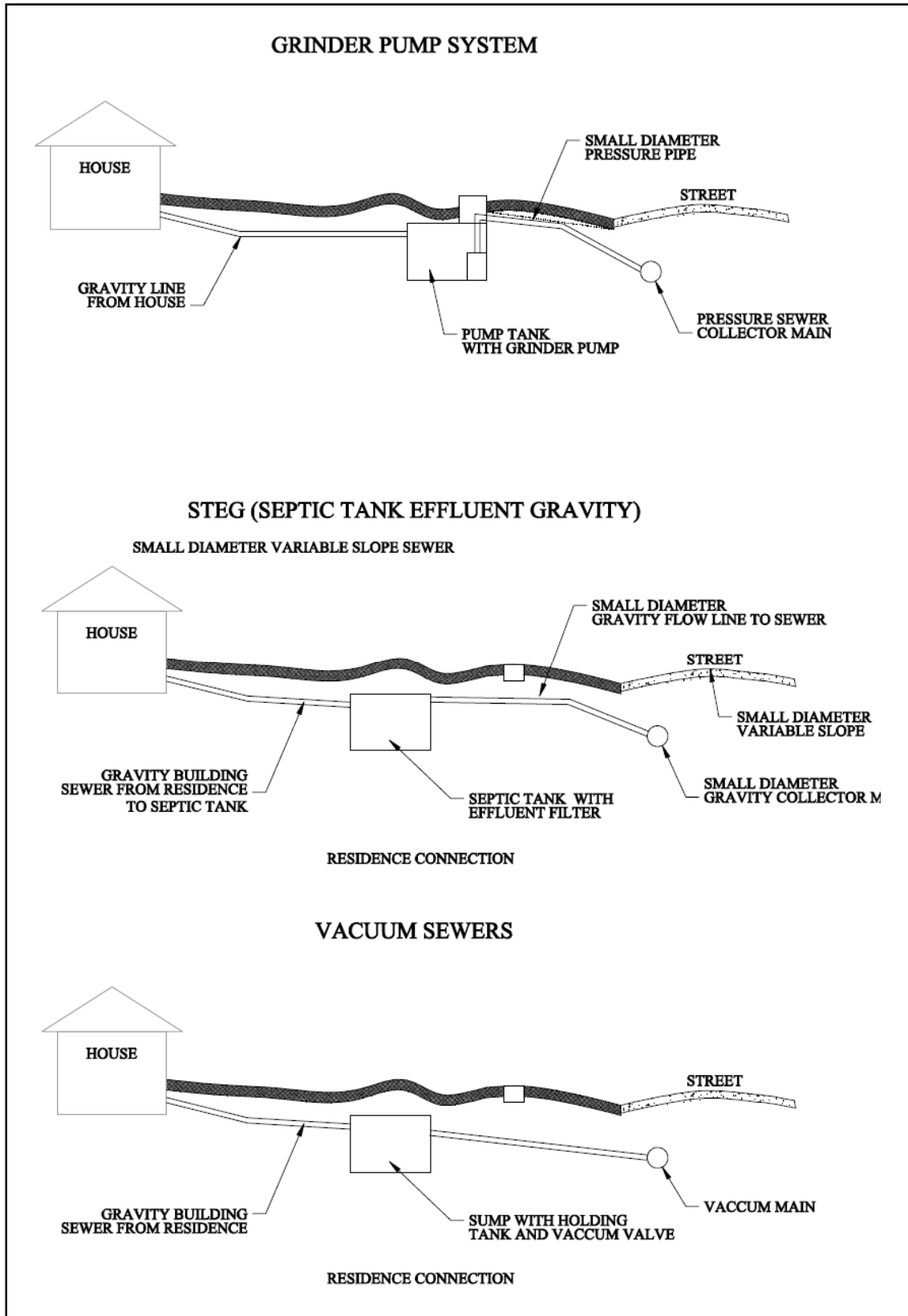

Figure 3-3 Diagram: Other Collector Systems, Showing Individual Connections



### 3.5.1.3 CONNECTIONS AND PIPING DESIGN CONSIDERATIONS

#### *Piping*

Piping should be graded and sized to allow for peak hydraulic flows of sewage/effluent.

Gravity piping should maintain a continuous and designed grade and use pipe which meets industry standards and is appropriate to the use.

Pressure conveyance and distribution piping should be of sufficient size to deliver the needed volume and pressure and use pipe which meets industry standards and is appropriate to the use.

#### MATERIALS

Every joint between pipes and fittings of dissimilar materials or sizes should be made by adapters, connectors or mechanical joints manufactured for that purpose and suitable to the use.

Pipe and fittings used for sewage or effluent conveyance or distribution should be suitable for the use and pressure as designed, and conform to appropriate CSA or equivalent U.S. standard. A table to aid pipe selection is provided in Appendix M.

#### *Ejector pumps and pumped raw wastewater conveyance*

See source control guidelines in Section 2.4 if using sewage pumps is critical to avoid excessive surge flows to the septic tank from sewage ejector pumps.

Ensure that dose volumes do not cause sewage flow to the septic tank to exceed standards (see source control guidelines in Section 2.4). A cycle counter and run time counter on the ejector pump will give an estimate of system flows if the pump serves the whole house.

See Appendix N and see Part 2 Section 2.4 (residential sewage standard) with respect to surge flows.

Septic tanks will need to have separate venting when solely supplied by pump. The effective internal area of the vent should be at least equal to the septic tank inlet pipe internal area, and vents should be protected from animal or insect access by corrosion resistant screens.

#### GRINDER PUMPS

Grinder pumps are not normally used in small onsite systems; where used, the AP should be aware that grinder pumps produce high levels of fine suspended solids.

Where grinder pumps are used, septic tank capacity should be increased by a minimum of 50%. Where a pre treatment plant is used, the manufacturer should be contacted for design adjustment. Additionally, surge flows should also be addressed.

Where the grinder pump serves only part of the flow (for example, in a basement suite), the increase in size should be proportional to the part of the Daily Design Flow. Note that concerns over surge flows should still be addressed.

### *Non-gravity sewer Collection systems*

Where grinder pump collection systems are used, septic tank or pre-treatment facility capacity should be increased by a minimum of 50%, as above.

For systems with more than two connections, STEP system design should address, at a minimum:

- the discharge characteristics of the pump chosen for each site;
- the septic and pump tank dimensions and design for each site, with tanks designed/installed to the standards in the pressure distribution section;
- effluent filter specifications;
- the control floats set points for each site;
- the pressure the pumps for each site will be discharging to in the common collector main;
- design of the collector main, including representation of the Hydraulic Grade Line for the main;
- an analysis of design flows demonstrating that all sites will be adequately served;
- confirmation that velocities in collector mains will be sufficient to ensure turbulent flow and prevent pipe plugging from slime or sediment accumulation;
- provision for maintenance of facilities and pipelines, and for monitoring of flows; and,
- provision in the design of details for each site installation.

STEG systems will need similar design considerations, and should, in place of pump considerations, include details of flow equalization provisions.

STEP, STEG, GP or vacuum collection systems should only be designed/installed by APs educated in and competent in the design/installation of such systems.

### **3.5.1.4 CONNECTIONS AND PIPING SPECIFICATIONS AND INSTALLATION CONSIDERATIONS**

#### *Piping*

General piping standards:

- where pipe is solvent welded, welds should be made in accordance with manufacturer guidelines. Primer should be used. All piping (except perforated pipe

in dispersal systems) should be watertight and should prevent infiltration of groundwater to the system;

- pressure piping systems should be pressure tested prior to commissioning; gravity sewers should be water tested per plumbing standard practice;
- it might be necessary to protect building sewers or effluent sewers from freezing by a frost box, culvert or other equivalent means, particularly if there is less than 1.2 m (4') of soil cover where it crosses under a ditch, driveway or path;
- pipe should be evenly and continuously supported (including under haunches — below the sides of the pipe),
  - should be bedded with clean material a minimum of 150 mm (6") on all sides and should be protected from damage that may be caused by settlement of filled areas (for example, at tank connections),
  - gravity piping should be installed on undisturbed ground or supported on compacted material to prevent settlement,
  - where pressure pipe is suspended in chambers, it should be supported at a minimum of 5' OC (On centre) (per Plastic Pipe and Fittings Association standards);
- where pipe trenches might concentrate groundwater flow, attention should be given to subsurface dams or collars to prevent water travel along the trench;
- piping for gravity effluent transport should not have a nominal pipe size smaller than 7.5 cm (3");
- a 10 cm (4") building sewer or effluent sewer should have a minimum grade of 1% ( $\frac{1}{8}$  inch per foot); and,
- a 7.5 cm (3") building sewer or effluent sewer should have a minimum grade of 2% ( $\frac{1}{4}$  inch per foot).

Note that piping standards are linked to any situation where pipe is used in the onsite system.

The B.C. Plumbing Code specifies that:

A building sewer must not change direction or slope between the building and public sewer or between cleanouts, except that pipes not more than 150 mm (6") in size may change direction

- by not more than 5° every 3 m (10"), or
- by the use of fittings with a cumulative change in direction of not more than 45°; and,
- the size and spacing of cleanouts must conform to the following table:

**Table 3-2 Cleanout Sizing and Spacing**

Size of Drainage Pipe (inches)	Minimum Size of Cleanout (inches)	Maximum Spacing (metres)	
		ONE WAY RODDING	TWO WAY RODDING
< 2.5	Same size as drainage pipe	7.5	15
3 and 4	3	15	30
> 4	4	26	52

To prevent damage or dislocation of piping during and after backfill, backfill should be carefully placed and be free of stones, boulders, cinders and frozen earth.

The inlet and outlet piping connected to the septic tank are subject to distortion caused by settling of the excavation around the tank. Using heavy wall pipe and close excavation to minimize the distance to undisturbed earth provides an added element of safety. Proper compaction below and support of the pipe is strongly recommended.

Where gravity sewer or pressurized forcemain is laid, provision for expansion and contraction of the pipe should be made, as a rule of thumb plastic pipe will change in length 1" per 100' per 10°F temperature change.

Where vent systems are screened, the screening should be of corrosion resistant and UV resistant material.

### *Sewage Ejector Pumps and Pumped Raw Wastewater Conveyance*

Sewage pumps located inside dwellings or buildings are covered by the B.C. Plumbing code and are not to be designed or installed by an AP who is not a qualified plumber.

Where sewage pumps are located outside the building the following applies:

Authorized Persons should:

- ensure installation addresses peak flows caused by the pump system;
- follow B.C. Plumbing codes and other applicable standards for good plumbing practices;
- ensure that the pipes, pump and fittings are protected from freezing;
- pump basins should be installed per criteria for pump tanks (Section 3.6.1), and the AP should:
  - equip the pump chamber with an audible high level alarm,
  - record pump dose volume, pump flow rate and pump run amperage at commissioning. Pump amperage should only be recorded by an AP who is not an electrician by use of non contact meter (for example, a clamp on meter) or installed meter,
  - ensure that sewage ejector transfer tank is structurally sound and watertight,

- provide adequate gas venting, either by provision of building drain and building sewer that connects to the stack vent on the building or by a separate vent, and,
- ensure that components are easily accessible and fitted with “quick disconnects” within 150 mm of the rim of the access riser for ease of maintenance and/or replacement. Use of cam lock type fittings is preferred over unions. Where frost could be a problem, APs should use insulated cover boxes or other method to prevent freezing at this access.

**Note:**

Where connectors or other components that must be accessed are 460 mm (18”) below the riser rim (as has been standard practice); then they are not reachable without presenting a confined space entry hazard (proximity of the face to the plane of entry and surrounding area where the presence of gases may be present).

### 3.5.1.5 CONNECTIONS AND PIPING MAINTENANCE AND MONITORING CONSIDERATIONS

Pump system maintenance in the house is a plumbing issue and falls outside of the Onsite System; however, the owner could be encouraged to follow the minimum maintenance standards per SWIS pumps/pump tanks.

These minimum standards should also be applied to STEP, GP and vacuum systems maintenance as per installation.

Gravity collection systems should be monitored for adequate flow/proper scouring.

Collection tanks are maintained as per septic tanks, Section 3.6.1 (linked standard).

Piping systems should be evaluated for leaks and the infiltration of water.

## **3.6 Treatment Facilities**

---

### **3.6.1 Septic Tanks (Type 1) and Sewage Effluent Tanks**

#### 3.6.1.1 TYPE 1 PERFORMANCE STANDARDS

The septic tank functions as a primary pre-treatment process and, by definition, produces a Type 1 effluent. See Part 2, Section 2.4 for performance standards for septic tanks/type 1 effluent.

In addition to treatment performance standards, the septic tank and effluent tanks should meet structural and installation standards that ensure health and safety are not impacted. These include watertightness and longevity. Pumped discharge tanks should reduce risk of overflow by use of alarms and suitably designed reserve volumes. (See Figure 3-4.)

Venting provisions should also ensure that the treatment facility does not cause a nuisance odour or impact public health by permitting flies or other vectors to spread disease from the facility.

As with collection systems, the infiltration of water into the tank should be prevented.

Standards presented in this section are linked to any situation where tanks are used in the onsite system.

### 3.6.1.2 TYPE 1 DESCRIPTION AND PRINCIPLES OF OPERATION

#### *Septic Tank*

**Figure 3-4 Compartmentalized Septic Tank.**

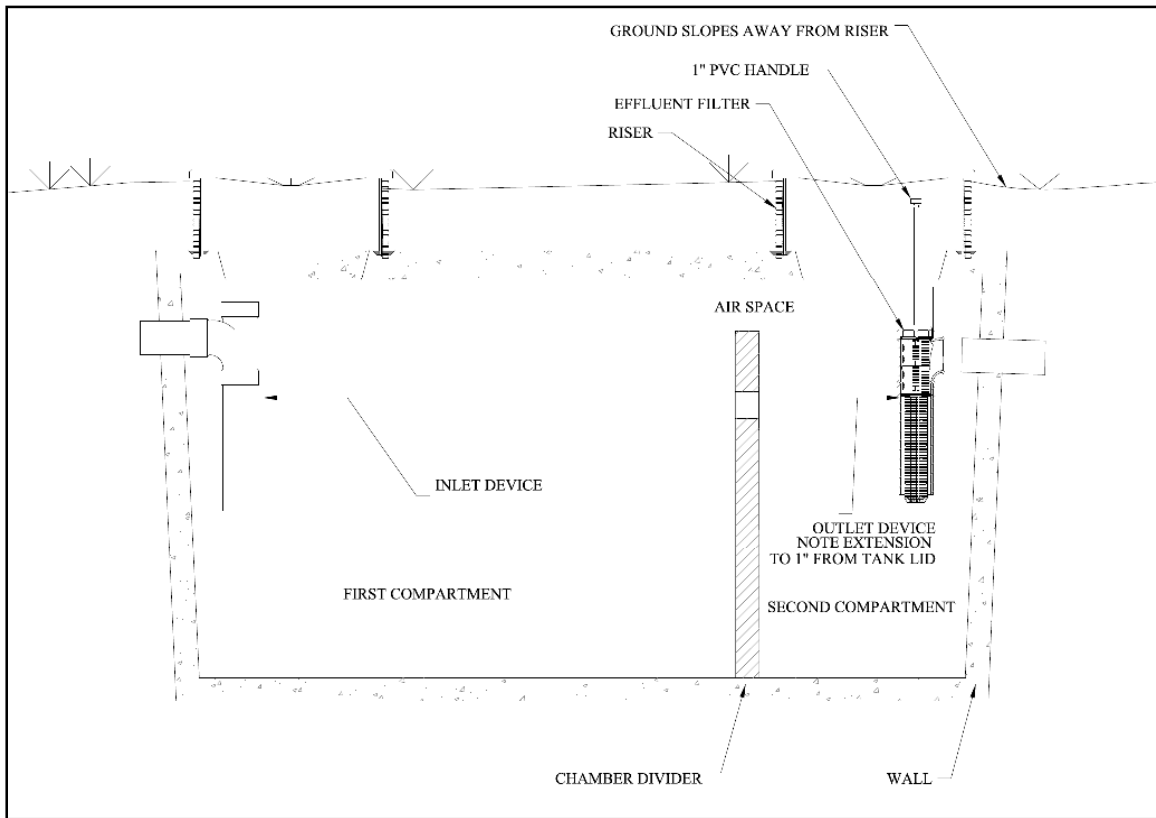

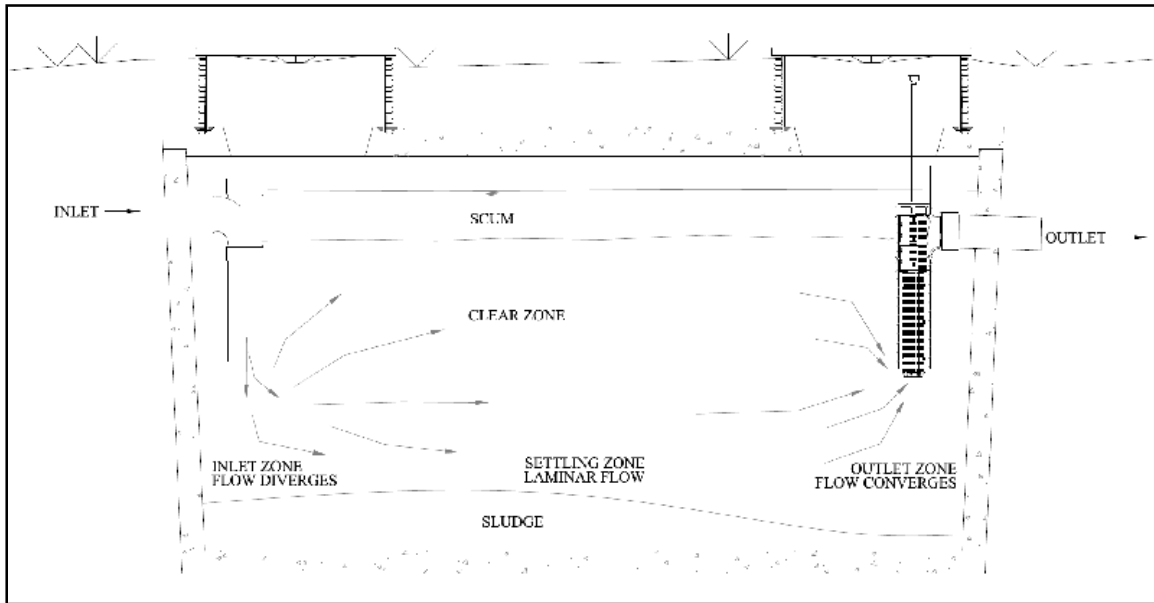
**Figure 3-5 Flow in a Septic Tank.**

The septic tank provides settlement/floatation, together with some anaerobic treatment and digestion of sludge (*see Figure 3-5*). Settlement is improved in tanks that have a shallow and long flow path, and settlement is a function of surface area in relation to flow.

The tank provides some equalization of short term peak flows; this could be improved by the use of an effluent filter with a modulating port or weir.

Treatment and digestion of the accumulated sludge and scum is improved with long sludge retention times. Flow rates through the tank should be controlled to prevent loss of sedimentation efficiency and to prevent scouring of previously accumulated materials.

An effluent filter is provided at the outlet of the tank, drawing from the clear zone, and protects the dispersal system whilst considerably improving the function of the tank.

### ***Other Tanks***

Septic tanks could also be used as “trash” tanks before a package treatment plant. In this case detention time is often shorter.

Grease interceptors are used to reduce oil and grease (O&G) (sometimes referred to as fat, oil and grease or FOG) levels in influent to residential sewage levels where necessary.

Flow equalization tanks are used to even out peaks in influent flow — to reduce peaks to those expected in residential sewage flow, and/or to improve treatment facility performance.

Effluent tanks are used in STEP collection systems and in pumped discharge systems.

### 3.6.1.3 TYPE 1 DESIGN CONSIDERATIONS

#### *General*

Septic tanks should be designed with a total minimum working volume as outlined in this section. They should also be designed to address surge flows if these are expected to be a problem.

Septic tanks should be provided with an outlet effluent filter per the standards of this section.

Working (or liquid) volume is measured from the inside bottom of tank to invert of outlet.

Septic tanks and effluent tanks should be structurally sound and watertight, and manufactured tanks should meet or exceed CSA standards when originally designed. Septic tank manufacturers should retest to the current CSA standard within one year of the standards' release. Septic tank manufacturers should provide an engineers' report or CSA certification when requested by an Authorized Person.

The septic tank will not house any means to dose or pump effluent that causes any variation in the minimum total working volume of the tank (*see Table 3-3 Minimum Septic Tank Volume* ).

When a septic tank has an integrated pump or siphon compartment, the pump compartment volume will not be calculated as part of the working volume of the septic tank.

Where two or more individual tanks are used to obtain the minimum working volume, as in Figure 3-6, the discharge from the first tank should come from an outlet baffle from about  $\frac{2}{3}$  of the liquid depth from the bottom of the tank.

**Figure 3-6 Septic Tank with Multiple Compartments Provided by Individual Tanks, and Pump Chamber in Third Compartment.**

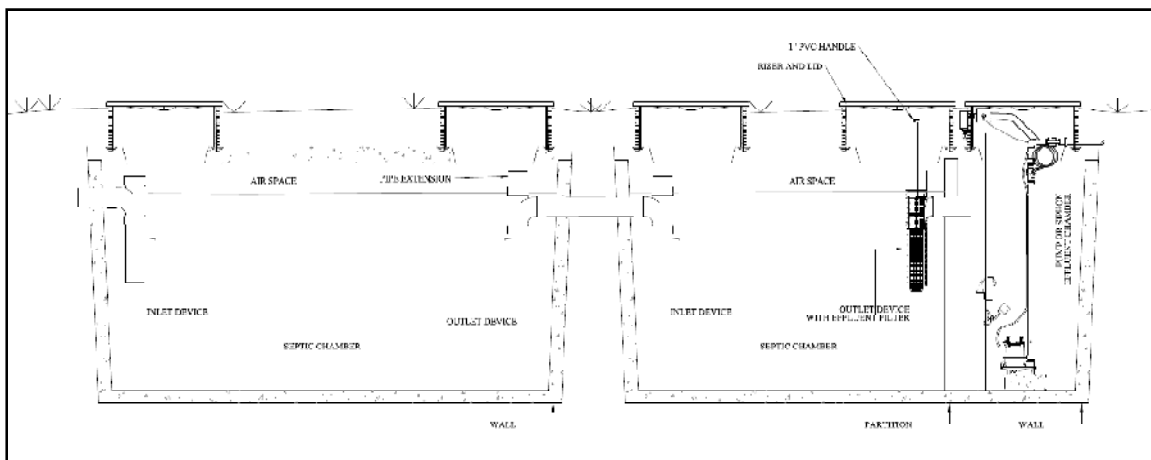

### *Shape and Size Guidelines for Septic Tank Design*

When designing or selecting a septic tank, the following points describe current research recommendations:

- liquid space (sludge clear depth at maximum sludge accumulation) 1 day average flow minimum;
- sludge/scum (septage) storage based on projected pump out interval,
  - For residential systems, recommended interval range for design 7–12 years. For 7 year interval, guideline 0.66 cubic metres per capita septage storage, for 12 years 0.95 cubic metres per capita. Short intervals lead to reduced digestion. See maintenance and monitoring considerations in Section 3.5.1.5;
- of the solids, the proportion is expected to be 75% sludge and 25% scum;
- sludge clear depth (sludge layer to bottom of discharge) min. 150 mm (6");
- reserve volume minimum 1 day average flow;
- air minimum 20 mm ( $\frac{7}{8}$ ");
- depth liquid min. 1m (39");
- sedimentation is improved by large length to width ratio;
- sedimentation is improved by large surface area to depth ratio;
- tank inlet minimum 305 mm (12") below liquid surface, 50 mm (2") below lowest scum layer;
- effluent filter inlet at centerline of clear zone, guideline 65–75% of minimum liquid level from floor of tank; and,
- tank liquid surface area divided by tank depth, guideline greater than three for any compartment.

(Liquid SA ÷ Depth > 3)
-------------------------

### *Effluent Filters*

Septic tanks should be properly fitted with a correctly sized effluent filter with an effective capacity to filter particles greater than or equal to 2 mm ( $\frac{1}{16}$ "). The effluent filter should be easily accessible for maintenance and monitoring purposes.

Intake for effluent filter should be in the clear zone, with sludge and scum accumulation at expected maximum. Intake should be 40% of liquid depth up from bottom to 40% of liquid depth down from liquid surface.

Filter housing should be designed to prevent flow or to filter flow out of the tank outlet when the filter is removed; alternately a sliding gate (knife) valve could be installed to provide this feature.

Effluent filters can also be installed in a separate chamber where installation in an existing septic tank is not practical.

The effluent filter should pass a minimum flow rate 50% greater than the peak daily flow, and when 85% clogged, be able to pass a flow rate equivalent to the daily flow.

The maintenance plan should include an estimate of expected cleaning intervals. The manufacturer should provide an estimated cleaning interval for their filters.

*Note:*

No two users are the same so intervals will vary greatly between homes. Monitoring is the most accurate way to establish a filter cleaning interval specific to the site.

Some effluent filters have modulating ports or weirs to reduce flow surge peaks. If these are installed, surcharge in the tank should be designed to prevent back up into the tank inlet pipe. This could require lowering the tank outlet.

**EFFLUENT FILTER ACCESS AND ALARM**

Filter should be easily removable and/or easily cleaned in place. Filter handle should be permanently attached and extended to within 150 mm (6") from access riser rim.

Static water level should be clearly visible to permit instant assessment for plugged filter. If an alarm is installed, it should meet the standards of the pressure distribution section and should require manual reset.

High-level alarms are recommended, particularly when a sewage basin or similar pumped device sends flows into the septic tank or other component. Where high water alarm is of float type, the tank (even in a two tank system) should be of a two-compartment type in order to reduce problems with scum.

*Septic Tank Volume Standards*

Table 3-3 shows minimum septic tank volume for flows up to 22,700 L/day. Calculations for Table 3-3 are as follows:

For design flows of up to 9,100 L/day, septic tanks should have a minimum working volume of three days detention time based on minimum design wastewater flow from Part 2, Section 4. Tank minimum size is 1,800 L.

Where a garburator or grinder pump is used it is strongly recommended that the size of septic tank be increased (by 50% minimum).

For Daily Design Flows from 9,100 L/day to 22,700 L/day, the minimum septic tank working volume should be calculated by:

$$\text{Minimum septic tank working volume (in litres) = } 15,000 \text{ L} + (\text{Daily Design Flow in litres} \times \text{a factor of } 1.34)$$

$$\text{Volume} = 15,000 + (\text{DDF} \times 1.34)$$

Working (or liquid) volume is measured from the inside bottom of the tank to invert of the outlet.

**Table 3-3 Minimum Septic Tank Volume**

Design Daily Sewage Flow (l gallons)	Design Daily Sewage Flow (litres)	Number of Bedrooms	Septic Tank working Volume (litres)	Septic Tank Working Volume (l gallons)
250	1,136 or less	1 and 2 bedroom unit up to 150 m <sup>2</sup> or 1,600 ft <sup>2</sup>	3,408	750
300	1,363	3 bedroom unit up to 175 m <sup>2</sup> 1,885 ft <sup>2</sup>	4,089	900
375	1,700	4 bedroom unit up to 235 m <sup>2</sup> 2,530 ft <sup>2</sup>	5,100	1,125
450	2,045	5 bedroom unit up to 295 m <sup>2</sup> 3,175 ft <sup>2</sup>	6,135	1,350
550	2,500	6 bedroom unit up to 355 m <sup>2</sup> 3,820 ft <sup>2</sup>	7,500	1,650
660	3,000		9,000	1,980
880	4,000		12,000	2,640
1,100	5,000		15,000	3,300
1,320	6,000		18,000	3,960
1,540	7,000		21,000	4,620
1,760	8,000		24,000	5,280
1,980	9,000		27,000	5,940
2,200	10,000		28,400	6,250
2,420	11,000		29,740	6,545
2,640	12,000		31,080	6,835
2,860	13,000		32,420	7,130
3,080	14,000		33,760	7,425
3,300	15,000		35,100	7,720
3,520	16,000		36,440	8,015
3,740	17,000		37,780	8,310
3,960	18,000		39,120	8,600
4,180	19,000		40,460	8,900
4,400	20,000		41,800	9,195
4,620	21,000		43,140	9,490
4,840	22,000		44,480	9,785
	22,700		45,418	9,990

**Reference:**

Loudon, T.L., T.R. Bounds, J.C. Converse, T. Konsler and C. Rock. 2005. Septic Tanks Text in (D.L. Lindbo and N.E. Deal Eds.) Model Decentralized Wastewater Practitioner Curriculum. National Decentralized Water Resources Capacity Development Project. North Carolina State University, Raleigh, NC.

**Grease Interceptors**

Grease interceptors should be used when sewage oil and grease levels exceed or are expected to exceed 150 mg/L in the sewage influent, they could also be used to address

the need for very low levels of O&G in effluent (for example, where treatment facility needs low O&G levels).

When used, grease interceptors are installed to pre-treat effluent from the grease producing plumbing (normally a kitchen) separately from other sewage flow. Passive (gravity based) grease interceptors should be designed to:

- have a minimum detention time of five days design flow from the kitchen or other facility served;
- maximize settling/flotation and cooling;
- be suitably vented;
- conform to structural needs for septic tanks;
- be vented in a way that prevents the impact of odour. and,
- produce effluent with maximum residential levels of O&G (100 mg/L) prior to discharge to the septic tank or treatment system. The tank or treatment system's performance should be monitored for commercial waste streams. Monitoring will need a sample collection point to obtain a grab sample.

Effluent filters could be advantageous for use in grease interceptors, where this is recommended by the manufacturer of the filter.

For mechanical systems, the grease interceptor should produce effluent with maximum residential levels of O&G 100 mg/L prior to discharge to the septic tank or treatment system. The tank or treatment system's performance should be monitored for commercial waste streams. Monitoring will need a sample collection point to obtain a grab sample.

### *Flow Equalization (Surge Flows)*

Where high short term peak flows are expected (for example, a large bathtub with 50 mm (2") trap or sewage ejector pump), flow equalization may be needed.

Alternatively, plumbing trap sizes could be restricted to restrict high peak flows. See Appendix N and see Part 2 Section 2.4 (residential sewage standard).

### *Watertightness Testing — All Tanks*

**All tanks, including septic tanks, tanks for installation of treatment plants and pump chambers, should be tested for watertightness after installation where practical** by filling with water (hydrostatic testing) or by vacuum testing. In both cases, the tank should be tested in the ready-to-use state. Inlets and outlets should be plumbed with the appropriate pipes, which can then be plugged for the test. Testing procedures may be found in Appendix O.

### 3.6.1.4 TYPE 1 SPECIFICATIONS AND INSTALLATION CONSIDERATIONS

#### **General**

Septic tanks or sewage effluent tanks should not be located within the setback distances laid out in Part 2, Section 2.3.3.3.

See design considerations, general, for structural specifications. (*See Section 3.6.1.3.*)

All tanks should be manufactured with flexible, watertight connectors that are cast-in-place.

Pre-cast concrete tanks should not be shipped or installed until reaching design strength.

#### **Access Openings**

A septic tank or effluent tank should have an access opening for each chamber that is level with or above the finished grade and have the ground graded to slope away. In areas of extreme cold climate, the riser should be insulated to prevent the tank from freezing.

Access openings will be over inlet and outlet baffles or tees and/or effluent filters.

Primary access should be of a suitable size to permit physical access to the tank and for inspection of and cleaning of the tank. Minimum standards of the 2005 CSA standard are minimum *internal* dimension of 400 mm (15.75") when over a single compartment or chamber and 610 mm (24") when over a divider and accessing two compartments or chambers (with minimum dimension of 305 mm (12") to each).

Riser diameter should be larger than the minimum opening as this will assist with access and with pump hose manoeuvring. *For example, if a 460 mm (18") circular opening is made in a tank lid, a 610 mm (24") nominal diameter riser would be appropriate.*

The size of opening needed will depend on the depth of burial — deeper burials need larger openings. As a guideline, where the depth of burial is over 0.91 m (36") primary accesses riser should have a 760 mm (30") nominal diameter.

Where depths are greater than 1.2 m (48") it may be preferable to use manhole access rings to a standard tank riser and lid. Minimum size for such access rings is 760 mm (30") internal diameter; however, larger ring size will permit easier access and may permit support on tank walls. Contact tank manufacturer for the tank lid loading allowed.

Where secondary access is needed (for example, to provide access to a tee in a centre compartment wall) the access should be appropriate for the purpose and provide proper and easy access regardless of tanks burial depth.

To increase safety and prevent unauthorized or accidental entry into a septic tank, access openings should be equipped with a secure lid or cover. Acceptable protective lid features include but are not limited to:

- a padlock;

- a cover that can only be removed with tools; or,
- a cover having a minimum weight of 29.5 kilograms (65 pounds); and,
- have beveled edges to prevent the cover from falling into the riser or tank.

An access opening extension (riser) should have watertight joints and be water tight at the connection to the tank.

### *Venting*

Septic tanks or effluent tanks should have separate venting when solely supplied by a pump or where there is no connection back to the house vent system. The vent effective internal area should be at least equal to the tank inlet pipe internal area or 7,800 mm<sup>2</sup> (12 in<sup>2</sup>) whichever is greater, and vents should be protected from animal or insect access by corrosion resistant screens. The screens should be accessible for maintenance.

### *Installation*

Authorized Persons should:

- locate all underground utilities before digging;
- ensure that all excavation, installation and backfilling work complies with ‘Workers Compensation Occupational Health and Safety Regulation’ Part 20.78 (WorkSafe BC) including confined entry requirements;
- inspect tank prior to installation to ensure tank is not damaged;
- perform a watertightness test as described in Section 3.6.1.3;
- backfill the tank evenly on all four sides in 30.5 cm (12") lifts with compaction to final grade;
- ensure that manufacturers of tanks provide instructions for the handling, assembly and installation of their tanks; and,
- ensure that risers and lids are not shifted or distorted when backfilling.

The inlet and outlet piping connected to a tank should be protected from distortion caused by settling of the backfill material. The excavation for a tank should not be any longer than is necessary to install the tank. This provides undisturbed earth closer to the tank to support the inlet and outlet piping connected to the tank. Piping connected to the septic tank or septic effluent tank should be supported to within 30 cm (12") of the tank on a solid base, fill beneath the pipe to be compacted.

Where ground or groundwater conditions may lead to tank flotation, prevent flotation by anchoring or other method, and/or install water table monitoring standpipes to monitor water level at tank (to prevent pumping out when water levels are high). Where water table monitoring standpipes have been installed at the tanks to address high water table concerns, this should be clearly stated in the maintenance plan and the water table monitoring standpipes should be accessible and clearly labelled.

To discourage flow of surface water into risers through lids ensure ground surface slopes to provide positive drainage away from lids where possible.

### 3.6.1.5 TYPE 1 MAINTENANCE AND MONITORING CONSIDERATIONS

Ensure that tanks pumped during winter conditions are refilled immediately, and that all plastic tanks are refilled immediately.

In all cases, refilling the tank to at least the soffit of the second compartment inlet will discourage toilet paper from entering the second compartment.

Pumping out of the tank should ideally be scheduled at the most favourable time of the year in that location based on freezing, high groundwater issues, etc. If high groundwater levels are confirmed or suspected, remove only the solids from the tank and refill with water immediately to the normal operating level.

Where groundwater monitoring and/or water table monitoring standpipes have been installed at the tanks to address high water table concerns, this should be clearly stated in the maintenance plan and the standpipes should be accessible and clearly labelled.

When cleaning the effluent filter, ensure scum/sludge does not exit tank, if filter does not provide for this retrofit suitable valve. Effluent filter cleaning should be done in such a way as to avoid contamination of the ground or surface water etc.

Table 3-4 provides likely pump out intervals; however, regular monitoring of the scum and sludge levels should still occur and is the most effective way of determining a pump out frequency for a specific installation.

**Table 3-4 Estimated Septic Tank Pumping Frequencies in Years**

TANK VOLUME (LITRES)	TANK VOLUME (IMP. GAL.)	HOUSEHOLD OCCUPANCY (NUMBER OF PEOPLE)					
		2	4	6	8	10	12
<b>PUMPING FREQUENCY IN YEARS</b>							
2,300	500	8.0	2.9	1.6	1.0	0.7	0.6
2,700	600	10.5	3.7	2.1	1.3	1.0	0.7
3,405	750	14.6	5.2	2.9	1.9	1.3	1.0
4,100	900		6.8	3.7	2.4	1.8	1.3
4,500	1,000		8.0	4.4	2.9	2.1	1.6
5,000	1,100		9.2	5.0	3.3	2.4	1.8
5,900	1,300		11.8	6.5	4.2	3.0	2.3
6,800	1,500			8.0	5.2	3.7	2.9
7,300	1,600			8.8	5.7	4.1	3.1

*Notes:*  
 For year-round residences, based on accumulation rates from Bounds (1988).  
 Entries above thick line show septic tanks that do not meet minimum septic tank volume criteria of the Standard Practice Manual assuming 2 occupants per bedroom.

As some digestion of sludge and reduction of sludge volume occurs after approximately three years, it is not appropriate to pump out tanks when sludge/scum accumulations do not need pump out.

As the scum layer ages, it becomes very firm, making it difficult for the vacuum hose to remove without considerable effort. The sludge layer could also need water to be added until the slurry consistency is suitable for the vacuum to remove. Thick septage is normally charged a higher rate because many facilities accepting the material have a surcharge to deal with the thicker septage. While larger tanks and long intervals between pump outs may retain and digest the solids better, costs will end up similar or higher due to the costs associated with pumping. Less frequent pumping may be more cost effective where travel time is significant.

In addition, more frequent pump outs is tied into to economical cleaning of other components which may need more frequent cleaning, but the cost to vacuum just a d-box or pump chamber would be very high if not including the septic tank at the same time. Thus, planning of maintenance should take into account economics and practicality.

Tanks should be evaluated during regular monitoring, at a minimum, for:

- sludge and scum accumulations. Pump when the sludge and scum thickness total  $\frac{1}{3}$  of the depth of the tank or as directed in the maintenance plan,
  - typical MAXIMUM criteria are: 12 inches (305 mm) or less from the top of the sludge to the bottom of the outlet baffle, and 3 inches (75 mm) or less from the bottom of the scum mat to the bottom of the outlet baffle. See above note on economics of pumping;
- clogging, damage, and proper placement of outlet baffle and filter. Clean each time it is checked or as needed to avoid clogging. Replace filter if damaged or deteriorating;
- signs of leaking or infiltration in tanks, penetrations and risers. Repair or replace if necessary;
- overflow/seepage problems, as shown by evident or confirmed sewage effluent surfacing at tank, or backup from septic or other effluent tank;
- risers and lids being above grade and having lids that are secure, surface water directed away from riser lids by ground slope; and,
- properly functioning floats. Movement should not be restricted. Floats should be positioned correctly and should actuate alarm or other circuit when moved to “on” position. Clean adjust and repair as necessary.

### *Septic Tank Abandonment*

When a septic tank is abandoned one of the following procedures should be taken in order to prevent future health and safety hazards:

- the contents of the tank should be pumped out and the septic tank, if structurally sound, should be filled with inorganic material such as soil or rock; or,

- the septic tank should be removed or broken up and the resulting excavation should be filled with soil or rock.

The dispersal field area can usually be left in place.

*Note*

Filling the tank will prevent caving in, collapse and floatation. Organic materials should not be used for this purpose as they can decay; possibly leading to caving in or collapse and can produce toxic and possibly explosive gases.

### **3.6.2 Type 2 and 3 Treatment Plants**

#### **3.6.2.1 TYPE 2 AND 3 PERFORMANCE STANDARDS**

The treatment plant functions as a pre-treatment process and, by definition, produces a Type 2, or Type 3 effluent. See Part 2, Section 2.4 for performance standards for treatment plants, and for minimum standards for monitoring/assurance of those standards.

In addition to treatment performance standards, the treatment plant tanks/enclosures should meet structural and installation standards that ensure health and safety are not impacted. These include watertightness and longevity.

Venting provisions should also ensure that the treatment facility does not cause a nuisance odour or impact public health by permitting flies or other vectors to spread disease from the facility.

Infiltration of water into the tank or system should also be prevented.

#### **3.6.2.2 TYPE 2 AND 3 DESCRIPTION AND PRINCIPLES OF OPERATION**

Treatment plants could be packaged or site built, and normally includes aerobic treatment processes in addition to settlement and anaerobic processes. They could include subsidiary processes, such as septic tanks, pump tanks, electrical compartments, flow equalization and sludge concentration tanks.

#### **3.6.2.3 TYPE 2 AND 3 DESIGN CONSIDERATIONS**

A Type 2 or 3 sewage treatment plant should:

- Be either approved by the National Sanitation Foundation (NSF) as meeting the requirements of the NSF 40 Standard, for Class 1 plants, relating to Residential Wastewater Treatment Systems; or in the case of a sand filter or other site-built plant, be designed, constructed and operated in accordance with standard practice for the technology employed; or,
- Be designed by a B.C. Professional Engineer and meet the standards of the regulation; or,
- have previously met B.C. Ministry of Health Services Standards for package treatment plants under Regulation 411/85.

Sewage that exceeds the maximum limits for residential strength sewage (as defined in Part 2) should not be discharged to a Type 2 or 3 treatment plant unless the plant or plant pre treatment system is specifically designed for such high strength waste.

In the case of plants that may discharge occasional spikes of high TSS effluent, the plant should be provided with a suitable barrier (effluent filter) prior to discharge to a SWIS.

Where a Type 2 or 3 treatment plant is in or includes tanks these tanks should be designed to meet the applicable standards for septic tanks/effluent tanks (Section 3.6.1) (linked standard).

#### 3.6.2.4 TYPE 2 AND 3 SPECIFICATIONS AND INSTALLATION CONSIDERATIONS

Treatment plant enclosures or tanks, or sewage effluent tanks should not be located within the horizontal setback distances laid out in Part 2, Section 2.3.3.

A Type 2 or 3 treatment plant tank should be installed to the standards for septic tanks/effluent tanks installation (Section 3.6.1).

Where a treatment plant is installed in an enclosure (example sand filter), the enclosure and/or other provisions must meet standard practice for the technology and should in all cases be watertight, prevent odour nuisance and should prevent flies or other vector from spreading disease from the facility.

Where a Type 2 or 3 treatment plant is in or includes tanks these should be specified and installed to meet the applicable standards for septic tanks/effluent tanks, as above.

#### *Venting*

Attention to proper venting design and installation is important. Complaints about odours due to venting problems are common.

Placing vents poorly can cause back pressures that force gases to escape from other, less desirable points. Examples of poor vent placement include: long distances for venting, placing vents where there are changes in air movement or air pressure due to weather (such as changes in air movements on a hillside throughout the day). This can also create a strain on blowers trying to overcome poor ventilation conditions.

Contact the treatment plant manufacturer for vent requirements specific to the plant. Consider use of underground venting systems.

All vents should be installed with corrosion resistant screens to prevent animal and insect access, and screens should be accessible for service. Where screens or filters are used, consider the actual effective area of the vent after the filter or screen obscures it.

#### 3.6.2.5 TYPE 2 AND 3 MAINTENANCE AND MONITORING CONSIDERATIONS

See Section 3.3.3.5 for minimum monitoring intervals for treatment plants.

See relevant points per septic tanks Section 3.6.1.5.

Manufacturers should provide comprehensive operating manuals for their plants, and should provide the AP with information to assist them in producing a maintenance plan, including guidance on appropriate monitoring/maintenance schedules, quality assurance and troubleshooting.

## ***3.7 Subsurface Wastewater Infiltration Systems (SWIS)***

---

### **3.7.1 Content of SWIS Section**

In this section the manual begins with comments general to all SWIS, and then presents a series of subsections:

- Trench dispersal technologies (*Section 3.7.3*)
- Effluent Distribution systems
  - Gravity trench (*Section 3.7.4*)
  - Dosed gravity (*Section 3.7.5*)
  - Zones and distributing valves (*Section 3.7.6*)
  - Pressurized Effluent Distribution (*Section 3.7.7*)
- Rock Pits — Drywells (*Section 3.7.8*)
- Seepage beds (*Section 3.7.9*)
- At grade bed and raised bed systems (*Section 3.7.10*)
- Pressurized shallow narrow dispersal trenches (PSND) (*Section 3.7.11*)
- Subsurface Drip Dispersal (SDD) (*Section 3.7.12*)
- Site drainage (*Section 3.7.13*)
- SWIS on sloping sites. (*Section 3.7.14*)

Within these subsections, there are many common features. In order to reduce repetition, in many cases one subsection will refer to another for details — for example all general coverage of pump tanks is included in the pressurized effluent distribution system section. This could be indicated by a specific section reference or by wording such as “per relevant pressure distribution system considerations.”

Note that sand mounds and sand-lined trenches are covered separately in Section 3.8.

## **3.7.2 SWIS General**

### **3.7.2.1 SWIS PERFORMANCE STANDARDS**

The SWIS is the final part of the onsite system, and should be designed, installed and maintained to prevent impact on health by contamination of water, groundwater or accessible soil with toxic materials or with pathogens

To improve dispersion and treatment in the soils receiving the effluent, technologies are designed and installed to improve distribution to the infiltrative surface, and to reduce saturation below that surface. They are also installed to encourage oxygen penetration to the infiltrative surface and below.

The SWIS includes piping and tank systems, which should be designed/installed/maintained and should perform as per above sections (3.5 and 3.6) (linked standard).

### **3.7.2.2 SWIS DESCRIPTION AND PRINCIPLES OF OPERATION**

The SWIS acts to disperse effluent through unsaturated soils, achieving hydraulic dispersal and treatment, including pathogen and nutrient removal. See Figure 3-7.

The physical characteristics of the applied wastewater, application rate, temperature, and the nature of the receiving soil affect the treatment processes.

Treatment in the soil is obtained by the detention of solids, nutrients and micro organisms on or in the soil particles. Unsaturated conditions in the soil facilitate the detention of particles and increase oxygen favoring effluent treatment. Unsaturated conditions also favour the activity of soil macro fauna.

Hydraulic dispersal is affected by the depth of the unsaturated receiving soil (both directly under the dispersal area and downslope), the soil's hydraulic conductivity, effluent application rate, land slope, and the area available for dispersal.

Figure 3-7 A SWIS Trench System, Showing Terminology

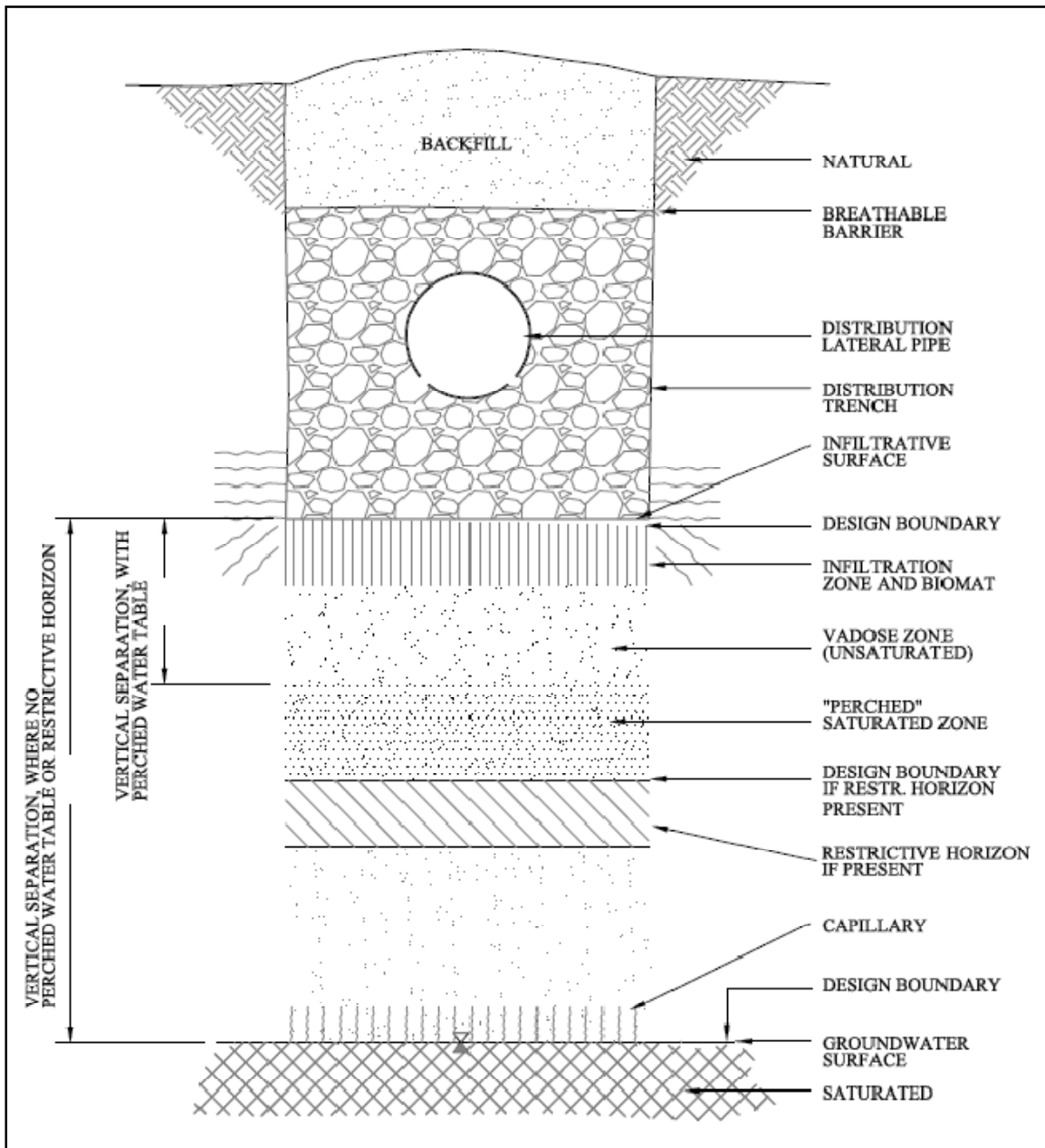

Subsurface Wastewater Infiltration Systems (SWIS) can be trenches, beds or drip dispersal areas. Additionally, sand mounds, sand-lined trenches and similar technology combine media filter treatment with direct dispersal to soils (see Section 3.8).

SWIS systems can be installed at various depths in ground or at grade to address vertical separation standards.

SWIS systems can be installed as trenches or beds, and the effluent can be distributed to the system by gravity or pressure.

### 3.7.2.3 SWIS DESIGN CONSIDERATIONS

For all systems, the Authorized Person should follow standards in Part 2 of this manual to determine Daily Design Flow, LLR and HLR, vertical and horizontal setbacks and effluent quality and plan, design, install and maintain the SWIS system to meet those recommended standards, as discussed, all standards and guidelines of Part 3 are linked to the use of Part 2 standards..

Where the Authorized Person considers it necessary, a reserve or partial reserve SWIS area could be set aside, either within the system design or in a separate covenant area. Covenants or other means can also be used to protect the receiving area and the discharge area. Provision of a reserve can also be addressed by including the reserve area within the primary field (i.e., between the trenches) to protect it from other use.

Where the Authorized Person considers it advisable, alternating SWIS areas can be used, allowing one area to rest for a period of months to permit the biomat to degrade. This system should be used with caution on coarser soils, where the biomat layer is important for treatment of the effluent and where this technique may lead to reduced treatment.

As flow to the SWIS system and pre-treatment system is a critical factor in system performance, a form of flow monitoring should be provided. Possible methods for flow monitoring include:

- a flow meter on parts of the building system that contribute to sewage flow;
- a flow meter on the discharge to field or as part of a treatment facility;
- a pump cycle and run time metres or datalogging on pump run events and run times; and,
- counter or datalogging of siphon cycles.

Where possible or economical, a record with time/day/date stamp will be most useful for system diagnosis. With a pumped system a datalogging flow meter will be advantageous for pump monitoring, and a flow meter will permit tests of pump operation.

#### *Site, Soil and Ecosystem Considerations*

Unsaturated conditions and unsaturated flow of effluent once applied to the infiltrative surface are essential to the proper functioning of the SWIS. In order to achieve this, the application of Daily Design Flow, HLR and LLR standards as per Part 2 are essential.

To reduce the opportunity for saturated flow, proper distribution and dosing of effluent to the infiltrative surface is important.

Shallow placement of the infiltrative surface and minimal cover encourages oxygen transfer, improves soil treatment and maximizes Evapotranspiration. 98.7% of soil biota population is in the upper 16" of the soil profile. (*See Figure 3-7.*)

The SWIS acts to disperse effluent through unsaturated soils, achieving hydraulic dispersal and treatment, including pathogen removal. For this process to be effective the soil should be in as close to an undisturbed state as possible, site impact on the dispersal

and receiving area should be minimal and it is recommended that as much natural vegetation and root structure be maintained as is practical.

In many cases, the natural ecosystem is important to maintain the soil characteristics that first made the site attractive for use as a dispersal area.

Removal of trees and stumps is neither required nor desirable. However, where trees are of a type with highly invasive roots (willow, aspen, bamboo, etc.), killing the stumps may be needed. Reestablishment of natural vegetation cover should be encouraged after system installation; this assists in effluent treatment and dispersal, and enhances soil structure.

Where there is concern over stumps rotting and causing settlement below a sand mound or similar system, consider removing stumps.

Where systems are installed using imported fill below the infiltrative surface, pressurized distribution should be used. Any fill below the infiltrative surface (other than aggregate for distribution) should be C33 sand or mound sand.

Fill used around the infiltration cell (for example, around chambers installed at grade) should be C33 sand or mound sand or be of equal or greater air permeability after settlement, in order to assure oxygen transport to the dispersal area.

Vehicles or heavy animal traffic should not be permitted on the finished system. This consideration could also apply to the receiving area for some sites. Heavy traffic compacts soils which limits oxygen transfer and increases the risk of frost damage.

### **3.7.3 Trench Dispersal Technologies**

#### **3.7.3.1 TRENCH SYSTEMS DESCRIPTION AND PRINCIPLES OF OPERATION**

Trenches can be installed as per Figure 3-8, below the ground surface. Trenches can also be installed at shallow depth — in which case trenches are partially below ground and partially covered, or “at grade.” In this case, the infiltrative surface is at the original grade and the system is covered with cover soil.

Note that there is a specialized form of at grade “trench” system termed the “Alberta At Grade System.” This system is not covered by this section.

**Figure 3-8 Trench Dispersal Layout**

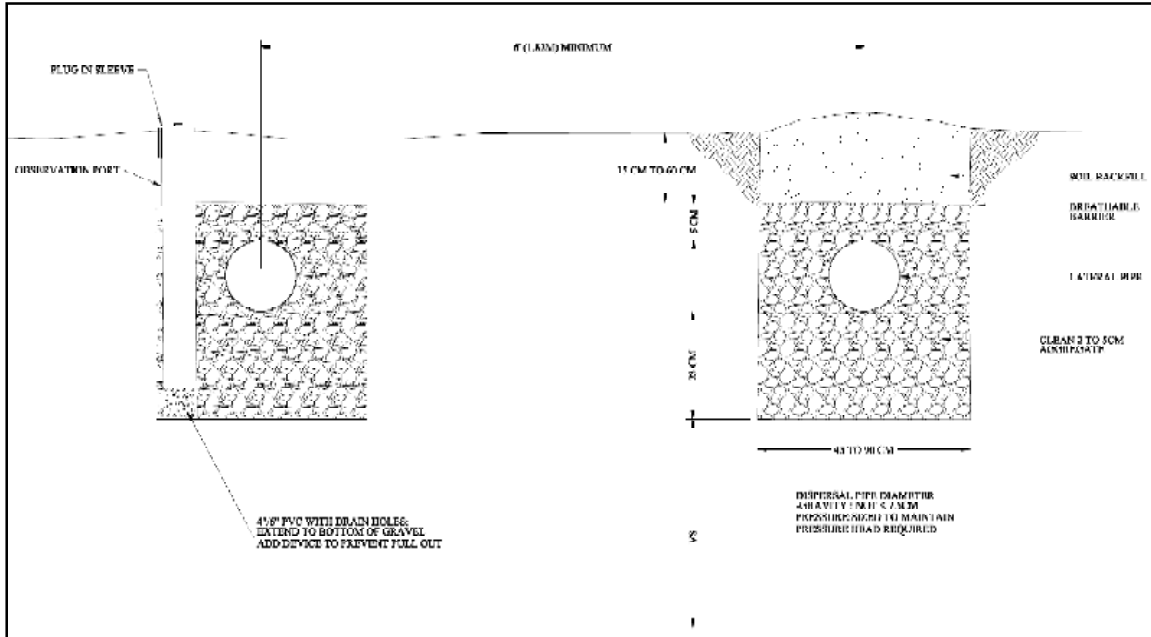

**3.7.3.2 TRENCH SYSTEMS DESIGN CRITERIA**

All trench systems should be sized such that the horizontal basal area ONLY (NOT including the sidewall area) is at least equal to the AIS (Daily Design Flow divided by the HLR).

Distribution systems are designed to ensure even distribution over this area and to reduce saturation of the basal area.

Trench infiltrative bottom area needed = Area of Infiltrative surface (AIS)

Daily Design Flow ÷ Hydraulic Loading Rate = Area of Infiltrative surface (AIS)

Total length of trenches = AIS ÷ the trench width.

Examples:

Daily Design Flow of 1,136 L/day, HLR of 15 L/day/m<sup>2</sup> and 0.6 m wide trenches

$$1136 \div 15 = 75.73 \text{ m}^2 \text{ trench bottom area needed}$$

$$\text{Total length of trenches} = 75.73 \div 0.6 = 126.22 \text{ m}$$

$$\text{Minimum Area of Infiltrative Surface (AIS)} = 75.73 \text{ m}^2$$

Daily Design Flow of 250 G/day, HLR of 0.3 G/day/ft<sup>2</sup> and 2 ft wide trenches

$$250 \div 0.3 = 833 \text{ ft}^2$$

Minimum Area of Infiltrative Surface (AIS) = 833 ft<sup>2</sup> trench bottom area needed

$$\text{Total length of trenches} = 833 \div 2 = 416.5 \text{ ft}$$

At grade trenches should be calculated in the same way, with NO allowance for area outside of the trench width.

For single and multiple pipe gravelless systems, effective trench width is taken to be the outside diameter of the pipe or pipe bundle.

For gravelless chamber systems, the effective trench width is taken to be, at a maximum, the outside dimensional width of the chamber in contact with the bottom of the trench or bed. A more conservative approach could be taken by using the actual exposed interior dimensional width of the chamber at the trench or bed bottom.

For geocomposite systems the effective trench width is taken to be the outside dimension(s) of the bundle(s) in contact with the trench or bed base (or sand layer, where used).

The inter trench spacing could be considered as a potential system reserve area.

### *Trench Dimensions*

Trench width should not be less than 30.5 cm (1') and not greater than 90 cm (3').

Trench length should not be greater than 30 m (100') for any one lateral in a gravity distribution system. Non-dosed gravity systems should preferably use shorter laterals (less than 50').

Spacing should not be less than 1.8 m (6') from centre line to centre line, except in the case of pressurized shallow narrow drainfields (see Section 3.7.11).

### 3.7.3.3 TRENCH SYSTEM SPECIFICATIONS AND INSTALLATION CONSIDERATIONS

Trench length should be level or with a positive slope in the direction of flow not exceeding 5 cm in 30 m (2" in 100'). Pressure distribution system trenches could be designed specifically to be sloped.

Trench length should be oriented parallel with contour (perpendicular to slope) and should follow the contour.

Do not over dig and refill trench. Scarify trench base, do not polish or compact with bucket or foot traffic.

#### *Aggregate*

Where soils have large macropores (very strong structure, saprolites or inceptisols with many rock fragments) consider using a 4" (100 mm) layer C33 sand or mound sand on the trench base to reduce the opportunity for flow concentration and resultant saturated flow. This could also be useful in cases where soils vary widely along the trench and where soils are prone to capping (sorting of fine particles). This layer can be termed a "blinding layer",

This sand layer can also be installed under a gravity system (i.e., is not considered to be fill in terms of Part 2 Vertical Separation standards) as long as it does not exceed 100 mm (4") in depth. In these cases Vertical Separation is measured from the top of the C33 sand layer. For pressure distribution systems this shallow sand layer is not included in the native soil vertical separation, but could be included in the total vertical separation.

The sand layer should be carefully settled but should not be compacted.

Gravel trench should have not less than 230 mm (9") drain rock depth between point of discharge and trench bottom.

Gravel trench should have a minimum of 5 cm (2") drain rock cover above effluent dispersal pipe.

#### *Cover*

Cover drain rock with a breathable barrier to prevent soil mixing with the drain rock. This could be breathable, water permeable geotextile material or equivalent (for example, a biodegradable layer such as untreated building paper, marsh hay or straw (100mm/4" depth or a graded aggregate filter). See below for geotextile sample specification. Where soil cover is uniform fine sand, this layer should be geotextile.

Cover breathable barrier with not less than 15 cm (6") of soil or sod. Soil cover should be air permeable and should be slightly crowned at installation to settle to level. Where marsh hay or straw is used as a barrier layer, cover soil mounding should take into account settlement of the barrier layer. See sand mound Section 3.8 for further discussion of cover soil.

Maximum cover is determined by frost considerations. Cover should not exceed 31 cm (12") unless needed to account for frost.

Cover to be graded to provide ground water drainage away from the trench or bed. On a slope, an upslope swale should be needed to divert any surface flows.

On sloping sites there is a risk of effluent concentrating in the feeder, relief or manifold trenches. During installation care should be taken to prevent this. Techniques include shallower excavation for the relief or manifold trench, clay or Bentonite plugs in the trenches, separation of the lateral trenches from the feeder/manifold trench by section of undisturbed soil.

### *Shallow and At Grade Trenches*

Where trenches are installed shallow or at grade, the dispersal system should still be covered to the minimum standards. The cover should be air permeable, but the top layer should also support grass and encourage rain to run off. This is similar to sand mound and at grade bed cover needs (see Sections 3.8 and 3.7.10).

When the system cover is complete it should slope to allow rainwater to flow away from the system, and an upslope swale could also be needed to divert any surface flow that would otherwise be “dammed up” by the system.

Cover soil, cover soil installation and cover vegetation should meet the standards for sand mounds (linked standard) (*see Section 3.8*); however, the inter trench cover soil (a minimum of 150 mm or 6" depth) can be placed on a layer of C33 sand or material with similar air permeability.

The cover should be extended a minimum of 61 cm (24") horizontally beyond the sides of the infiltrative surface and then at maximum 2h: 1v slope. In the case of at grade trenches, this will normally mean coverage of the entire area.

For shallow trenches on a sloping site, if the cover soil does not extend over the entire area, it is recommended that any water be diverted that could accumulate between the trenches during heavy rain.

Where trenches are installed at grade, surface preparation of the “trench” basal area should be per procedure for at grade beds (see Section 3.7.10) (linked standard).

Where trenches are raised, surface preparation of the “trench” basal area and fill below the trench base should be per procedure for at grade beds (see Section 3.7.10) (linked standard).

Pressure distribution is needed for any raised system, and is strongly recommended for at grade trenches (linked standard).

### ***Construction***

All work should be performed when the site is dry and compaction from machinery will not cause significant damage to the distribution area soils' structure or hydraulic conductivity.

Trenches should be constructed in a manner that does not damage the native soil structure by smearing or compacting of soil surface.

Any smearing or compacting that does occur should be repaired by scarifying the surface of the distribution area or the trench walls.

Finished distribution area should be graded so that rain or ground water can drain away from the site.

Seeding or sodding the site immediately after construction is recommended to prevent erosion and to encourage reestablishment of soil structure in cover soil.

### ***Aggregate (Drain Rock) Specifications***

Aggregate media specifications:

- aggregate should be non-biodegradable (concrete rubble is not an acceptable aggregate) and have a hardness  $>3$  on Standard Measurement of Hardness (MOH's) scale of hardness (the stone can scratch a copper coin without leaving any stone on the coin);
- effective size range from 12 mm – 63 mm ( $\frac{1}{2}$ "– 2  $\frac{1}{2}$ "); and,
- all aggregate should be washed and screened and contain less than 5% fines, silt or clay coating.

### ***Geotextile Sample Specification***

If geotextile is used to prevent soil cover mixing with aggregate it should be lightweight and of "non woven" type. The textile should be hydrophilic (not repel water). The specifications of Table 3-5 are provided as a guideline. Geotextile can also be specified based on soil particle size analysis.

**Table 3-5 Geotextile Specification**

Property	Test Method	Average roll value
Grab Tensile, lbs.	ASTM D4632	35 minimum
Grab Elongation, %	ASTM D4632	50 minimum
Puncture, lbs	ASTM D4833	10 minimum
Trapezoidal tear, lbs	ASTM D4533	11 minimum
AOS, US Sieve #	ASTM D4751	20 minimum
AOS, US Sieve #	ASTM D4751	70 maximum
Flow Rate (gal/min/ft <sup>2</sup> )	ASTM D4491	100 minimum
	Or equal Canadian standard	

*Note:*

AOS = Apparent Opening Size.

Ref. State of Wisconsin Code, Washington State RS&amp;G

Washington State recommends for Soil with 50% or less particles by weight passing U.S. No. 200 sieve, AOS maximum #30 Sieve; and for Soil with more than 50% particles by weight passing U.S. No. 200 Sieve, AOS maximum #50 Sieve.

***Gravelless Effluent Dispersal Systems***

Gravelless systems or artificial aggregate systems offer alternatives to traditional pipe and gravel distribution. See Section 3.7.3.2 for sizing standards.

Proprietary gravelless systems should have the following:

- a load bearing capacity not less than AASHTO H-10;
- be installed with consideration to manufacturer's instructions;
- chamber systems should have an effective side wall open area of not less than 35% of bottom infiltrative area (which void ratio should be maintained for the life of the system) and should be installed with suitable cover material on top and sides to ensure air infiltration to chamber, geotextile cover should not be used except where provided by the chamber manufacturer for such use;
- where the native soil is a uniform fine sand ("sugar sand"), there could be risk of sand infiltration into the sidewall vents of chambers, in this case ONLY geotextile cover (as approved by the manufacturer) should be used. In other cases, geotextile cover should NOT be used;
- chamber systems used for pressure distribution on soils with silt content (including Loam soils), where crusting/capping could be a concern, OR where soils have large macropores, should be placed upon 100 mm (4") of C33 sand or mound sand;
- backfilling of sidewall areas of chambers with C33 sand could be necessary when soils are of a type that will compact in this area and reduce oxygen transport;
- drain orifices (those installed at 6 o'clock) in pressure systems in chambers should use orifice shields;

- recent research indicates that pressure distribution to chambers with wide orifice spacing may lead to spot loading of the basal area,
  - chambers over 610 mm (24") in nominal width used for pressurized distribution should have no more than 0.37 m<sup>2</sup> (4 ft<sup>2</sup>) per orifice,
  - where chambers are used as the bed for a sand mound or similar technology, they should have no more than 0.37 m<sup>2</sup> (4 ft<sup>2</sup>) per orifice or be placed on an aggregate bed to improve distribution;
- synthetic aggregate system should:
  - provide not less than the equivalent void space as a gravel aggregate system (not less than 35% void space), which should be maintained for the life of the system; and,
  - withstand the pressure of backfill without distortion or compaction.

### Observation Ports and Vents

Install a 100 mm (4") or 150 mm (6") diameter effluent monitoring pipe 100 – 150 mm (4 – 6") from the distribution pipe that has perforations beginning at 50 mm (2") below the distribution pipe discharge. For pressure distribution systems a combination observation and cleanout access could be used at the trench end; however, a mid trench observation port should also be installed. These pipes should be capped and should be anchored to prevent pull out; this can be accomplished by use of a toilet flange, tee or other method.

For chambers, install monitoring port pipes as per manufacturer instructions.

Gravity distribution systems can include vent pipes, particularly in cases of repairs to systems with excessive cover. These pipes connect to the top of gravity distribution laterals and extend a minimum 305 mm (12") above grade, terminating in a vent cap or other arrangement so the opening is downward facing. These should be of the same size as the gravity lateral pipe. In chamber systems, these can be directly combined with the observation ports. (See Figure 3-9.) With standard laterals, this combination will mean use of a tee or wye connecting to the vent pipe above the level of the aggregate in the trench.

**Figure 3-9 Vent and Combination Vent and Observation Port Examples**

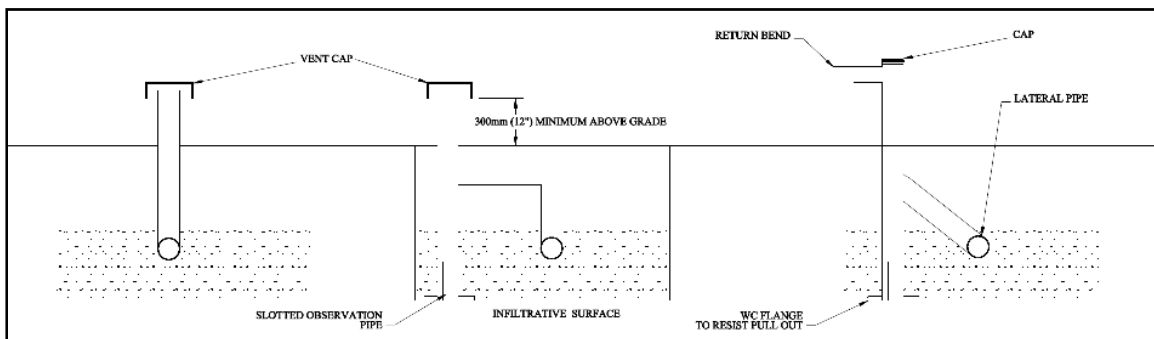

### 3.7.4 Gravity Trench Distribution System

#### 3.7.4.1 GRAVITY TRENCH DISTRIBUTION DESCRIPTION AND PRINCIPLES OF OPERATION

Gravity flow is considered to be the case where the laterals are not under sustained pressure during the dose event. This includes dosing systems where the effluent is dosed to the SWIS by pump or siphon.

**Figure 3-10 Gravity Trench Distribution**

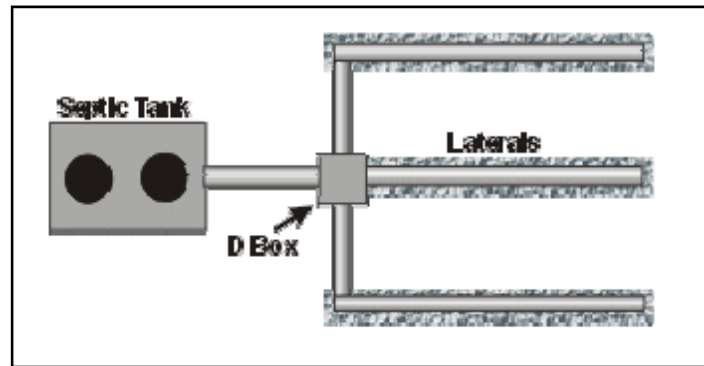

#### 3.7.4.2 GRAVITY TRENCH DISTRIBUTION DESIGN CONSIDERATIONS

Gravity flow should not be used for distribution areas exceeding 152 lineal metres of 610 mm wide trench (500 lineal feet/2 foot wide trench) or for distribution systems greater than 93 m<sup>2</sup> (1,000 ft<sup>2</sup>) infiltrative surface.

Gravity systems larger than this size should only be constructed if DOSED. These systems should use dosing to sequential distribution, pressure manifold distribution or dose to Distribution Box (D-Box only for slopes below 15%). Serial distribution should not be used for these larger systems. Dosing systems should be designed and constructed per the standards of this manual (linked standard).

Where a larger gravity field is to be repaired at the time of the repair, the system should be dosed (not trickling). The discharge area should also meet Part 2 standards for minimum soil vertical separation and minimum horizontal setbacks. (*See Section 2.3.3.*) If the minimum vertical and horizontal separation cannot be met, the field could be converted to pressure distribution (assuming the necessary vertical and horizontal separation can be achieved for pressure distribution).

Provide detailed design notes, specifications and distribution system layout plans.

#### *Distribution Box (D-Box)*

To improve distribution to the laterals, a distribution box (d-box) is used. Splitter tees and tipping diverters can be used for the same purpose. A tipping bucket system can also be used within a d-box to improve distribution with non dosed gravity systems.

A d-box should include devices to adjust flow to individual laterals (often called “speed levellers”).

If the d-box is vented, the vent should extend a minimum 305 mm (12") above grade, terminating in a vent cap or other arrangement. The opening should be downward facing and the vent should be tightly screened with stainless steel insect screening.

D-box systems will only be suitable where laterals are of approximately the same length.

On more steeply sloping sites d-box and splitter tee systems give no opportunity for effluent from a trench to back up into the box or tee and flow to another lateral if this becomes necessary. In these cases a pump dosed serial or sequential system is preferable.

A distribution box, as shown in Figure 3-11, should:

- be watertight;
- be structurally sound, and resistant to hydrogen sulphide;
- provide even flow to each individual lateral by adjustable outlet levelling devices;
- be placed on a compacted and level 2.5 cm (1") sand or gravel bed; and,
- provide a watertight riser access at grade to provide for maintenance (insulation could be necessary).

**Figure 3-11 Distribution Box**

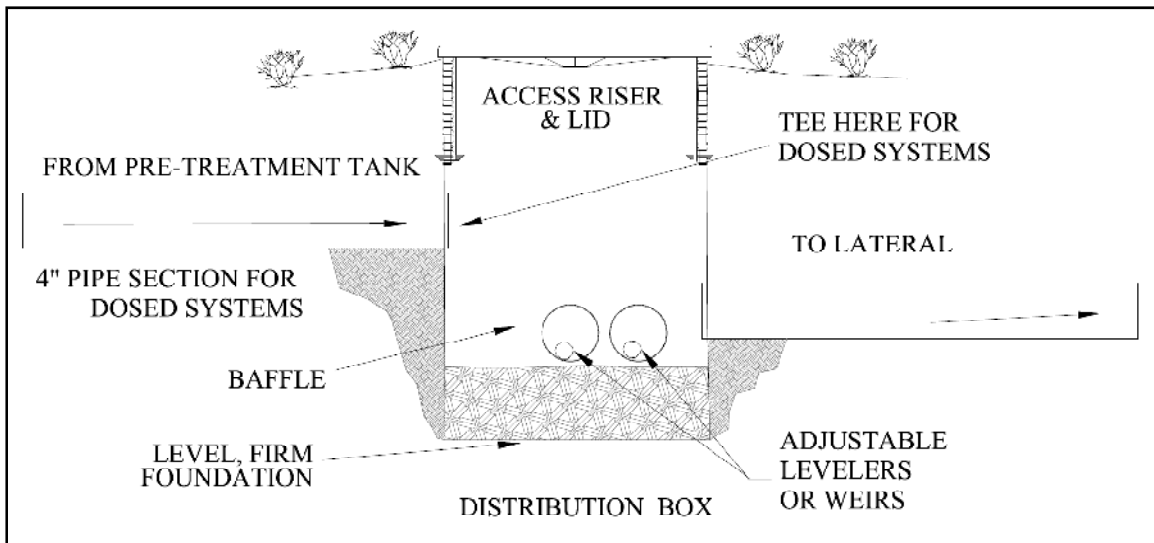

### 3.7.4.3 GRAVITY TRENCH DISTRIBUTION SPECIFICATIONS AND INSTALLATION CONSIDERATIONS

See trench systems, Section 3.7.3.1:

- piping should be placed on centerline in trench;

- piping grade should be level or with a positive slope in the direction of flow not exceeding 5 cm in 30 m (2" in 100');
- perforated pipe nominal size should be not < 7.5 cm (3") for gravity distribution;
- perforations should be not < 1.27 cm (0.5") for gravity distribution;
- perforation should begin and end not less than 30.5 cm (12") from trench end wall for gravity distribution;
- dispersal piping should be capped at end or to be joined to adjacent lateral in a loop;
- piping should be placed in such a way as to ensure the best and most even effluent dispersal along width and length;
- d-box should be installed level on undisturbed ground or compacted gravel; and,
- d-box or splitter tee should be connected to the lateral piping by solid pipe laid at a minimum of 1/8" per foot (1%) slope on native soil or compacted gravel.

#### 3.7.4.4 GRAVITY TRENCH DISTRIBUTION MONITORING AND MAINTENANCE CONSIDERATIONS

With all gravity distribution systems, check for uniformity of flows into and out of the distribution box and note the extent of solids residue on interior surfaces between site visits. Correct uneven flows by adjusting outlet levelling devices, or clean the box and/or outlet pipes to remove solids if needed.

At a minimum the regular monitoring of the field area should include evaluation of:

- indications of surfacing effluent;
- vegetation — type and growth patterns, inappropriate vegetation;
- traffic impact, including compaction from foot traffic;
- inappropriate building or drainage in or near the dispersal area;
- impervious materials or surfaces installed or developed over the discharge area;
- excavations near the discharge area that may lead to breakout;
- abnormal settling or erosion;
- monitoring observation ports for evidence of ponding in trench or bed. Check and record the depth of ponding. For a dosing system check the observation ports before a dose; and,
- drainfield pipe and lateral condition and performance. A pipe camera should be used regularly for this purpose.

Regular monitoring of a distribution box or drop box will include evaluation of:

- uneven settling, structural integrity;

- levelness of inverts of outlets, level in relation to inlet in drop box, pipes should slope to laterals;
- uniformity of flow at box,
  - This will include inflow and outflow, evenness of flows to laterals and also confirmation of flow direction. Use of dye is recommended;
- depth of effluent in the box; and,
- solids and grease accumulations in the box,
  - box and attached pipes should be cleaned and vacuumed out at appropriate intervals.

Flow splitting tees and pressure manifolds should be evaluated for proper operation and even distribution, as well as for structural integrity and solids/grease accumulation.

Where a distribution valve is used it should be evaluated for proper switching.

### **3.7.5 Dosed Gravity Distribution System**

#### **3.7.5.1 DOSED GRAVITY DESCRIPTION AND PRINCIPLES OF OPERATION**

These systems are also termed “Flood-dose”. With these systems the gravity system is dosed by a pump, siphon or similar device, this improves distribution to the system. It is also used to compensate for elevation differences between the septic tank and distribution field.

Dosing systems provide periodic resting and re-aeration to the soil between doses, and attempt to apply effluent to the drainfield’s infiltrative surface at a rate less than the saturated hydraulic conductivity of the soil.

These systems are still considered gravity systems and should meet the applicable standards of the gravity distribution Section 3.7.4 (linked standard)

#### ***Pump to D-Box***

A normal d-box is used to divide the dose. Splitter tees could also be used with dosed systems.

Trenches should be the same or very close to the same length to use this system, and use on sloping sites is less desirable.

#### ***Serial or Sequential Distribution***

In serial distribution, an upper distribution line is recommended to fill before the effluent overflows into a lower line. This method is recommended for use only with dosing systems and will need a sloping site. This is achieved by use of overflow (relief or cross over) pipes or by drop boxes. (See Figure 3-12.) Trenches can be of different lengths. This system has the disadvantage of filling one trench before the next one fills. Drop box systems may be preferable due to easier access for monitoring and for service.

With relief lines, the relief line connects the crown (top) of the upper lateral to the next lateral downslope. The lines are normally located near the trench centre but are separated by 1.5 m – 3 m (5' – 10') to reduce short circuiting of effluent. To prevent flow concentration and short circuiting, the relief lines are surrounded by a low permeability “dam.” This could also be used in the lateral trench on either side of the relief connection. The relief lines are solid pipe.

Where drop boxes are used in serial distribution, boxes are located at opposing ends of the laterals so that effluent can flow through one lateral before moving to the next. The connecting lines are solid pipe and are bedded in a low permeability soil dam. (*See Figure 3-12.*)

In sequential distribution, one trench or trench pair is loaded to a predetermined level before passing through a relief line or device to the beginning of the succeeding trench or trench pair; the effluent does not pass through the distribution media before it enters succeeding trenches. This is usually achieved through the use of drop boxes. (*See Figure 3-13 and Figure 3-14.*)

The connections between distribution lines are made with non-perforated pipe placed in undisturbed soil, and a dam is built up at the trench to prevent draining to the lower trenches.

Serial or sequential distribution with shallow trenches could be used to maximize Evapotranspiration as a form of Evapotranspiration bed suited to sloping sites.

Drop boxes can be used on low slope sites by setting the downstream boxes 5 cm (2") below the upslope unit.

Figure 3-12 Serial System (Top and Side Views)

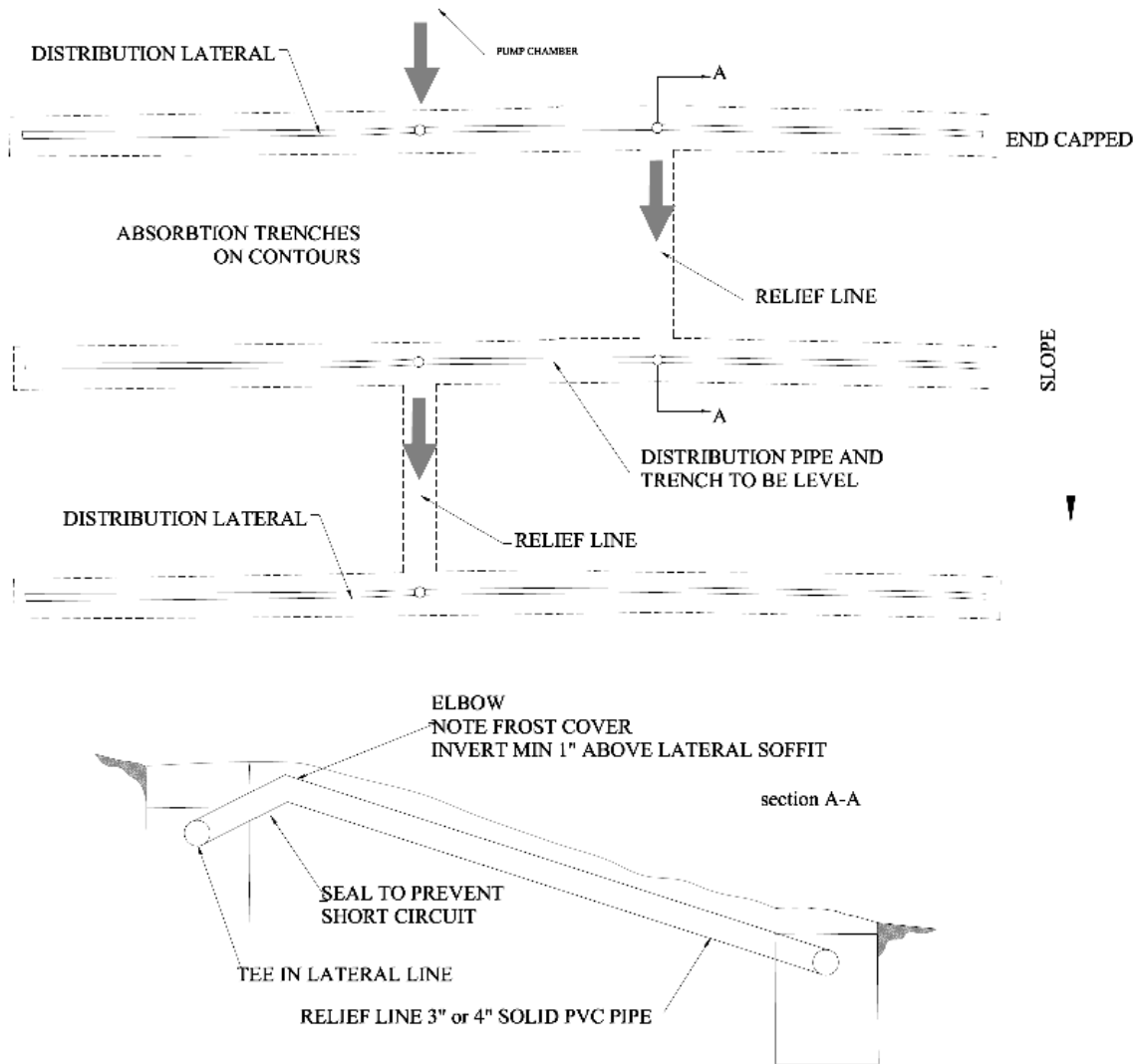

**Figure 3-13 Sequential (Drop Box) System (Top View)**

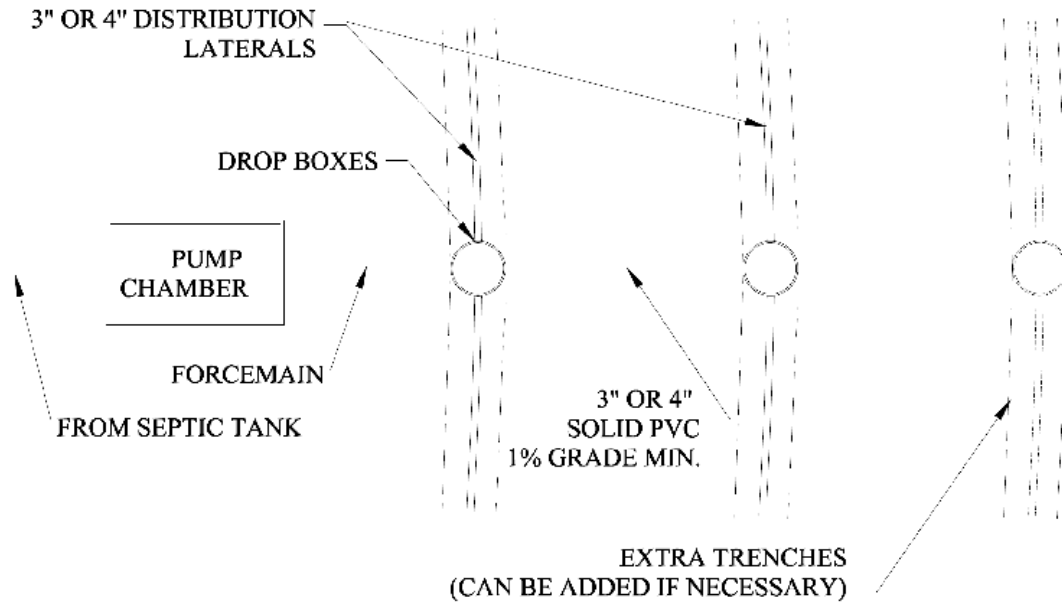

**Figure 3-14 Sequential (Drop Box) System (Side View)**

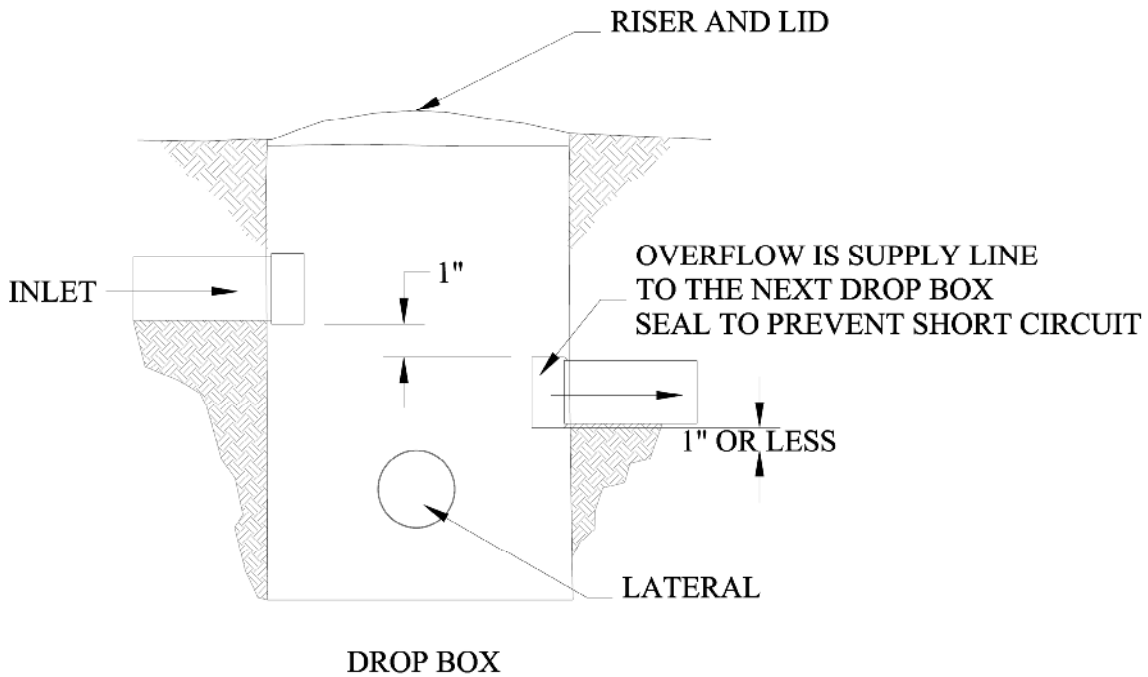

**Pressure Manifold**

This is a pressurized flow splitting device, using a short manifold with a series of orifices sized to ensure equal distribution to a network of gravity trenches.

Trenches can be of different lengths and the system could be flat or on a slope.

This system needs care in design, but gives the best possible distribution for a gravity system and can be particularly applicable to a repair situation.

This technique should only be used by APs educated in and competent in design/installation of pressure manifold systems.

### 3.7.5.2 DOSED GRAVITY DESIGN, SPECIFICATION AND INSTALLATION CONSIDERATIONS

#### *General*

Trench system design and installation is as per gravity trench systems, Section 3.7.4.

Follow pump chamber sizing, pump or siphon, chamber and forcemain design, specification and installation standards for pressurized distribution systems (Section 3.7.7).

Dose volumes should be 1 – 2 × per day (note that gravity distribution is not suitable for use on the higher permeability soils that would need more frequent dosing). Larger dose volumes should be used for serial distribution. Dose volume should also be a minimum of 65 to 100% of the draining volume of the dispersal and distribution piping.

Any box or valve or splitter tee should be accessible for maintenance. This should include a riser to surface with access lid per d-box specifications.

On sloping sites, there is a risk of effluent concentrating in the feeder trenches. Care should be taken to prevent this during installation. Techniques include: shallower excavation for the feeder pipe trench, clay or Bentonite plugs in the trenches and separation of the lateral trenches from the feeder trench.

With larger systems proper distribution will need considerable care in design and installation, proper commissioning is critical in ensuring that the system works as designed.

#### *Pump to D-Box*

Where effluent is pumped or siphoned to the d-box, a baffle or tee should be provided to improve distribution, and the box should be sized to ensure flow can be accommodated.

One method to moderate flow velocities to the box is to have the pressure line enter a 100 mm pipe about 1 m (3') before the box in order to slow the incoming flow.

The use of speed levellers in the box is not recommended with a dosed flow because this can create a restriction.

During installation, a test of equal distribution should be included at commissioning.

This system should not be used on slopes greater than 15%.

### ***Serial or Sequential Distribution***

During installation, a test of adequate distribution should be included at commissioning.

Where the relief or overflow pipe system is used, it is important to avoid effluent short circuiting along the pipe trench. Installation should include careful compaction of a dam of lower permeability soil around the overflow pipes to above the level of the trench aggregate system. This could require mounding of cover soil over the pipe to prevent frost problems.

With a drop box system, the downstream overflow pipe is traditionally installed to put its invert 1" above the soffit of the lateral pipes (see Figure 3-12 and Figure 3-14), however, lower placement could also be acceptable. Depending on the design of the drop box a baffle or tee could be required to prevent dosed effluent bypassing the upper lateral.

During commissioning, the system should be adjusted to provide as equal distribution to all laterals as possible, this could require the use of flow restrictions (example speed levelers with enlarged holes) on the upper lateral inlets and adjustment of the overflow pipe level.

Serial system laterals should be installed completely level when relief pipes are not at ends of laterals. In other cases, follow specification for gravity trench systems.

### ***Pressure Manifold***

Pressure manifold systems should be designed to ensure even distribution and installed to permit service. Use an air/vacuum valve to prevent siphoning, if needed. Design of a pressure manifold should include manufacturer or AP design specification and detail of how the design meets the distribution criteria.

If flow adjustment is by orifice plates, these should be removable for service and orifice size should be specified.

Installation should include at commissioning a test of equal distribution. The test could be achieved through measurement of flow or volume to each lateral connection and this is easier to do if the connections are easily disconnected at the lateral.

### **3.7.5.3 DOSED GRAVITY DOSED GRAVITY TRENCH DISTRIBUTION SYSTEM MAINTENANCE AND MONITORING CONSIDERATIONS**

Maintenance and monitoring considerations are as per gravity trench systems, Section 3.7.4, and as per relevant procedures for pressure systems Section 3.7.7 (linked standards).

The system should be monitored for even distribution. With dosed systems this will include evaluation of distribution and check that effluent reaches the ends of all lines with the dose, this check should be performed as a part of system commissioning and the dose volume adjusted to ensure this occurs.

Pressure manifolds should be evaluated for proper operation and even distribution, as well as for structural integrity and solids/grease accumulation.

Where a serial or sequential distribution system is used:

- consideration could be given to taking upper laterals out of service for resting to allow biomat to degrade;
- even if only the first one or two boxes are in active use, all boxes should be checked during monitoring and maintenance as the non-used boxes have a tendency to deteriorate due to H<sub>2</sub>S gases rolling downhill from one box to the next; and,
- observe the flow behaviour with some tracing dye and inspect pipes and laterals using the pipe camera for the same reasons as the single box system.

Any pressurized system component should be evaluated for leakage.

### **3.7.6 Zones and Distributing Valves**

As a SWIS becomes larger, effective distribution could require use of two or more zones, dividing the area or even using several separate areas. These are often dosed alternately. Use of zones could also allow more flexibility in distribution.

Dosing of separate zones could be achieved by multiple pumps or siphons with separate transport lines, or by a single transport line and alternation of zones at the field.

Distributing valves can be used to distribute effluent to multiple gravity or pressure drainfield zones.

#### **3.7.6.1 HYDRAULIC DISTRIBUTING VALVES, DESIGN, SPECIFICATION AND INSTALLATION CONSIDERATIONS**

Hydraulic distributing valves (also called “indexing valves”) use water flow/pressure in the line to actuate them. Each time the pump is turned on, the valve rotates to dose the next drainfield zone.

Where these valves are used, design should include allowance for the head losses in the valve and fittings.

Distributing valve installation should be specified with the following features:

- unions to allow easy removal of the valve;
- pea gravel or similar bedding to improve maintenance access;
- clear sections of pipe for visual inspection of valve operation;
- a ball valve on the inlet for quick testing of valve operation; and,
- provisions to prevent freezing.

Install these valves at high point of field, or install using check valves to prevent back pressure on the valve. Ensure forcemain to valve remains full to prevent air slugs causing erratic operation of the valve. An air/vacuum valve could be needed to improve drainage of the valve and filling of the forcemain.

### 3.7.6.2 ALTERNATING FIELDS, DESIGN, SPECIFICATION AND INSTALLATION CONSIDERATIONS

An alternating field or trench system is where zones or laterals are used alternately with long rest periods (for example, 3 months on and 3 months off) . These systems allow time for biomat to be broken down during the resting periods, which may increase system life.

In the case of a gravity distribution system, zones are alternated by using either a full flow valve or a d-box with diverter plates. For pressure systems ball valves are normally used.

The design should address the possible reduction of in-soil treatment that may occur due to lack of biomat. This is particularly likely to be a problem in higher permeability soils and with gravity distribution.

### 3.7.6.3 ZONES AND ALTERNATING FIELDS, MAINTENANCE AND MONITORING CONSIDERATIONS

Maintenance of alternating fields should include proper alternation, and this should include monitoring of trenches for biomat condition. In a gravity system, a pipe camera can be used to assist in monitoring of biomat condition. Observation port monitoring, or the observation ports of a chamber system will also assist.

Zone valves should be checked for proper operation. Any check valves should be checked for proper operation.

## 3.7.7 Pressurized Effluent Distribution System

### 3.7.7.1 PRESSURIZED DISTRIBUTION DESCRIPTION AND PRINCIPLES OF OPERATION

The pressurized conveyance system relies upon pump(s) or siphon(s), to pressurize the dispersal system laterals. These small diameter laterals have orifices drilled in them in an even pattern throughout the field to discharge the effluent to the infiltration area. This provides even distribution of effluent to the dispersal system.

The pump or siphon will be housed within a pump tank (pump chamber).

Pressure distribution is also used in the design of mound systems and similar technology.

This low-pressure distribution process can control the effluent volume application rate by using either:

- an on-demand pump dosing system where pump activation will be controlled by a float system or floats/relays to dose effluent based on effluent level in the pump chamber; or,
- a timed application rate where pump activation will be controlled by a timer or control panel based on a dose time and inter dose interval. This system improves in soil treatment by encouraging unsaturated conditions at the infiltrative surface and also reduces the chance of hydraulic overloading due to system misuse or infiltration of water into the system.

Timed application provides greater control of the dosing volume and dosing intervals.

**Figure 3-15 Pressure Distribution System**

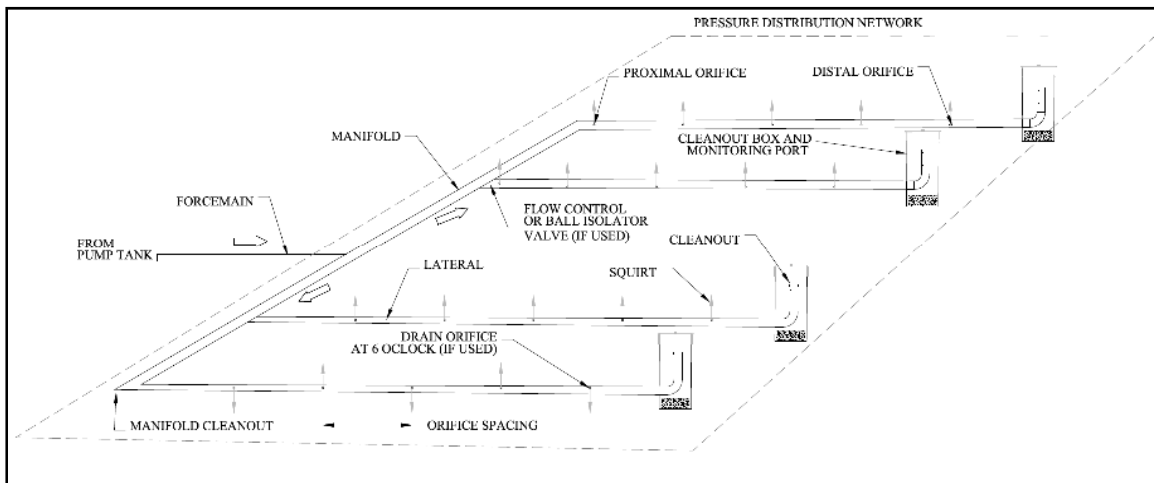

### 3.7.7.2 PRESSURIZED DISTRIBUTION DESIGN CONSIDERATIONS

Follow relevant provisions of trench systems, Section 3.7.3.

The design of pressure distribution network systems is described in Appendix P, and a worksheet is provided, with tables for a simplified method of design.

Effluent should be pre-treated to a Type 1 effluent quality with particulate filtration of not < 2 mm ( $\frac{1}{16}$ " ) prior to distribution.

Flow velocity in pipelines should be not less than 0.6 m (2') per second and not more than 3 m (10') per second.

Ball valves could be installed for lateral isolation during lateral flushing.

Where the forcemain drains back to the pump tank and pipe is installed in contact with soil or aggregate an air/vacuum valve could be installed to prevent suction of debris into system.

An orifice could be used in the discharge assembly to allow for pump priming, drain back or to prevent siphoning. If the orifice is open during pump cycling then that orifice flow

should be included in calculations for pump sizing in pressure distribution design. See worksheet in Appendix P.

Manifolds or risers from manifolds could be drained by using weep holes at the riser base or in the manifold; these are bedded in drain rock. In these cases, vertical separation from this infiltrative surface should be maintained to standard as per Part 2. Care should also be taken to avoid flow concentration in these areas from the lateral trenches.

Orifices and residual head:

- Orifice discharge variation or per-square foot loading rate variation from proximal (nearest) to distal (farthest) end of distribution network should be not greater than 15%, and within one lateral not more than 10% (this can be estimated by variation in residual head (squirt height));
- residual head height at distribution orifice should be no less than 61 cm (2') for  $\frac{3}{16}$ " and larger orifices, not less than 1.5 m (5') for smaller orifices,
  - it is recommended that residual head be designed above minimum in order to allow for future pump wear,
  - residual head measurement is most accurately made by use of a flexible tube or clear plastic tube;
- orifice spacing should result in 0.56 m<sup>2</sup> (6 ft<sup>2</sup>) of infiltrative surface per orifice (infiltrative surface) or less. Closer spacing is better, and is particularly desirable where avoidance of flow concentration and macropore flow is critical, or in sand mound/trench systems dosed by demand. (For example, for a 61 cm (24") trench, this is 90 cm (36") spacing),
  - chambers over 610 mm (24") in nominal width where used for pressurized distribution should have no more than 0.37 m<sup>2</sup> (4 ft<sup>2</sup>) per orifice,
  - where chambers are used as the bed for a sand mound or similar technology, they should have no more than 0.37 m<sup>2</sup> (4 ft<sup>2</sup>) per orifice or be placed on an aggregate bed to improve distribution,
  - orifices in beds should be staggered on adjacent laterals;
- orifice diameter guideline, a minimum of  $\frac{3}{16}$ " for Type 1 effluent,  $\frac{5}{32}$ " for Type 2 or Type 3 effluent; and,
- each orifice to be protected with an orifice shield regardless of orientation. Note that gravelless chambers can serve as orifice shields when orifices are in 12 o'clock locations.

Lateral:

- should be spaced not more than .90 m (3') for bed;
- should be spaced not less than 1.8 m (6') for trench;
- diameter should be not greater than 38 mm (1.5");
- diameters less than 25 mm (1") should be used with caution due to difficulty in cleaning;

- should be provided with an accessible cleanout access:
  - cleanout end to be equipped with a screw cap or plug fitting;
  - cleanout should be accessible from grade; and,
  - where cleanout cap is used for test orifice, leave test caps for maintenance provider's use.

In the specifications, the Authorized person should:

- determine the total dynamic head needed by the system for proper operation at the flow application rate, using a system curve to select the pump (or equal for siphon system) and forcemain;
- determine the distribution discharge orifice size and spacing, lateral and manifold diameter to ensure even distribution;
- design and specify appropriate dosing regimen (see below); and,
- provide detailed design notes, specifications and distribution system layout plans.

### *Sloping Sites*

On sloping sites, prevent drain back of higher to lower laterals and ensure that all laterals operate at equal flow per basal area. See schematic Figure 3-16 to Figure 3-19 for strategies.

**Figure 3-16 Tee to Tee Manifold, with Check Valves.**

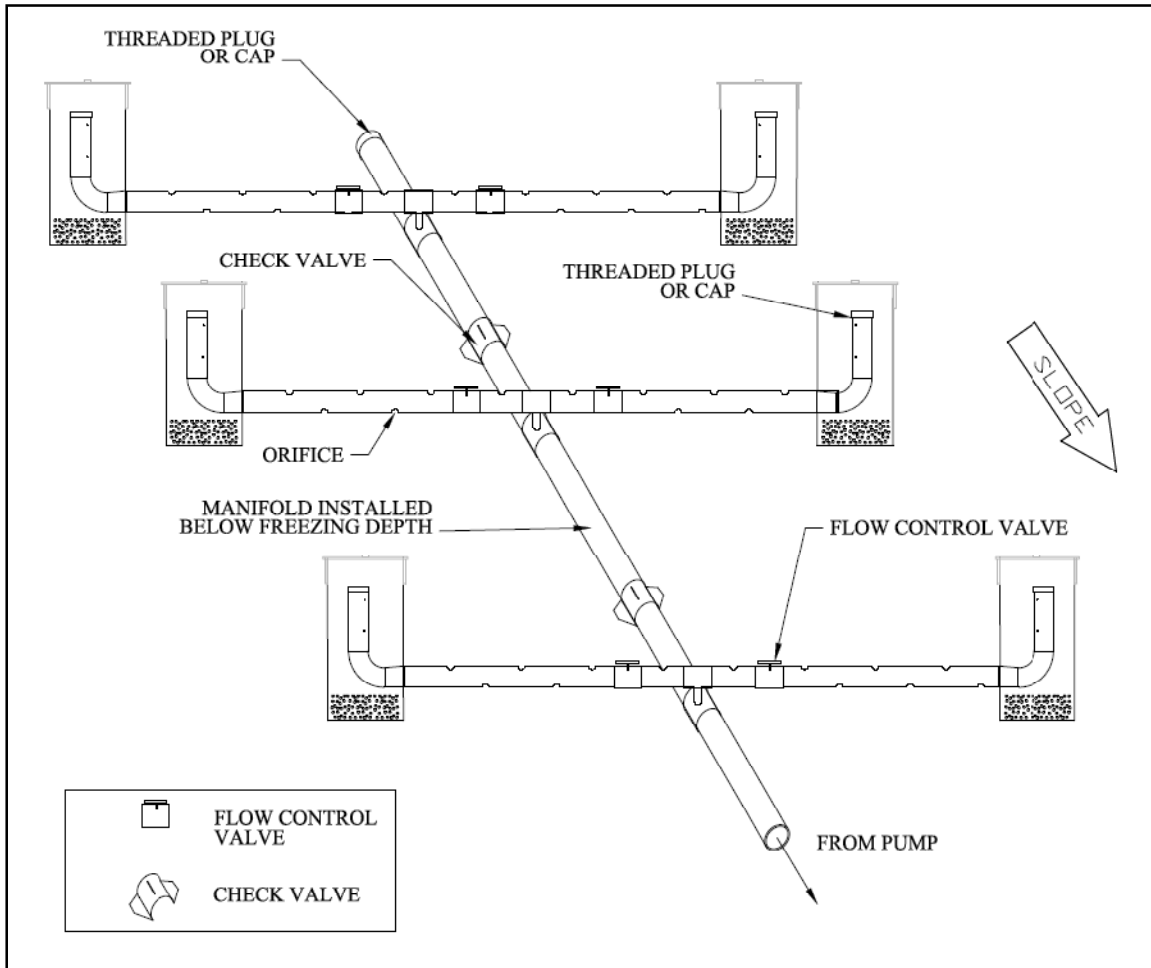

Note: Check valves should be installed with unions and access boxes for service.

This technique can also be used with the laterals dipping from the manifold connection tee to the lateral trench. If the dip is sufficient, this will prevent upper laterals siphoning down to the lower laterals. In this case the check valves will not be needed. This also allows a good earth dam between the manifold and lateral trenches.

In some cases an orifice is drilled at the base of the riser pipe (from manifold to lateral connection) to drain the riser pipe. This is intended to prevent freezing. The orifice should be bedded in a minimum of 150 mm (6") depth of drain rock, and vertical separation should be maintained.

Attention should be paid to prevent effluent concentrating in the manifold/forcemain trench.

Figure 3-17 Cross Manifold, with Check Valves.

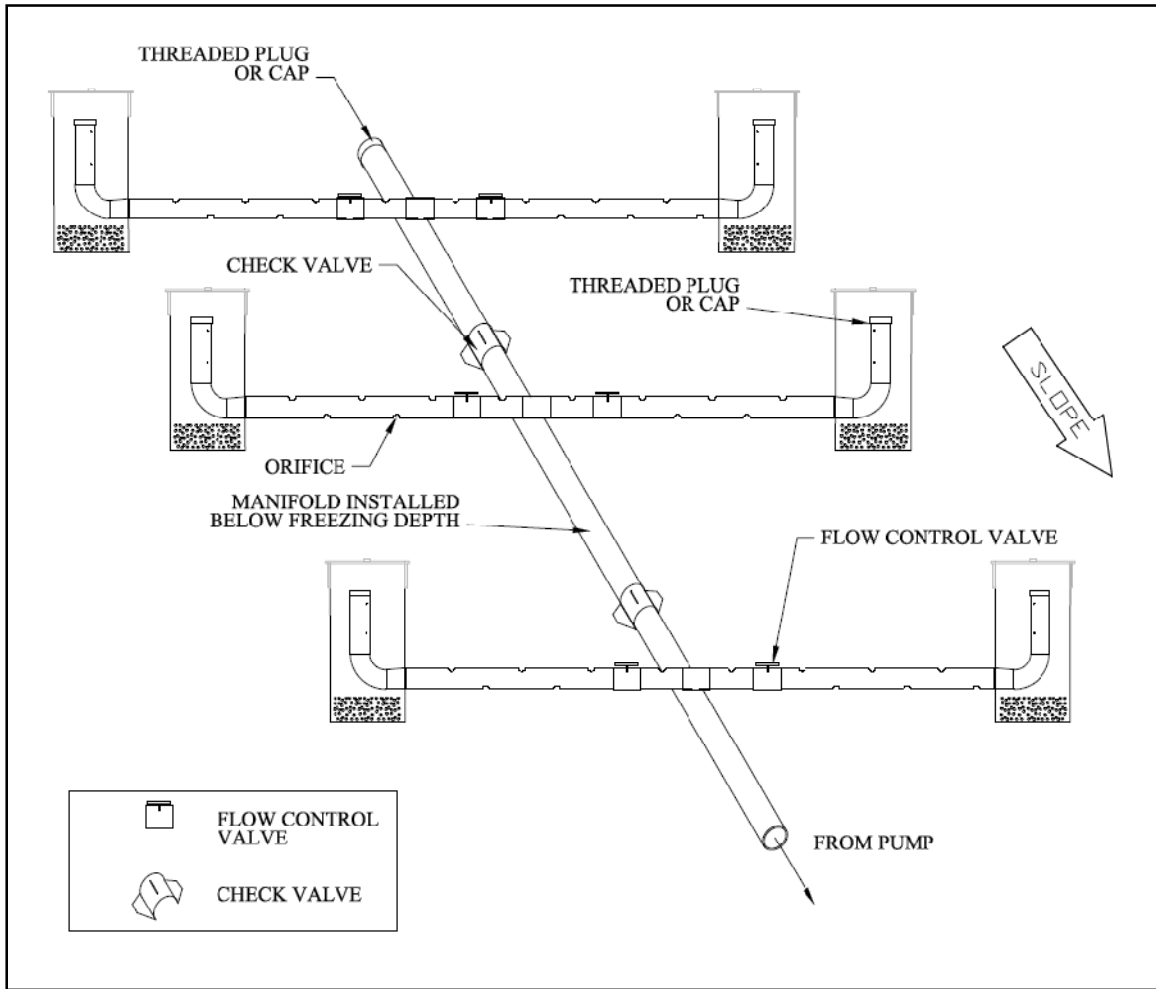

**Figure 3-18 Short Upslope Header Manifold, with Feeder Pipes to Laterals.**

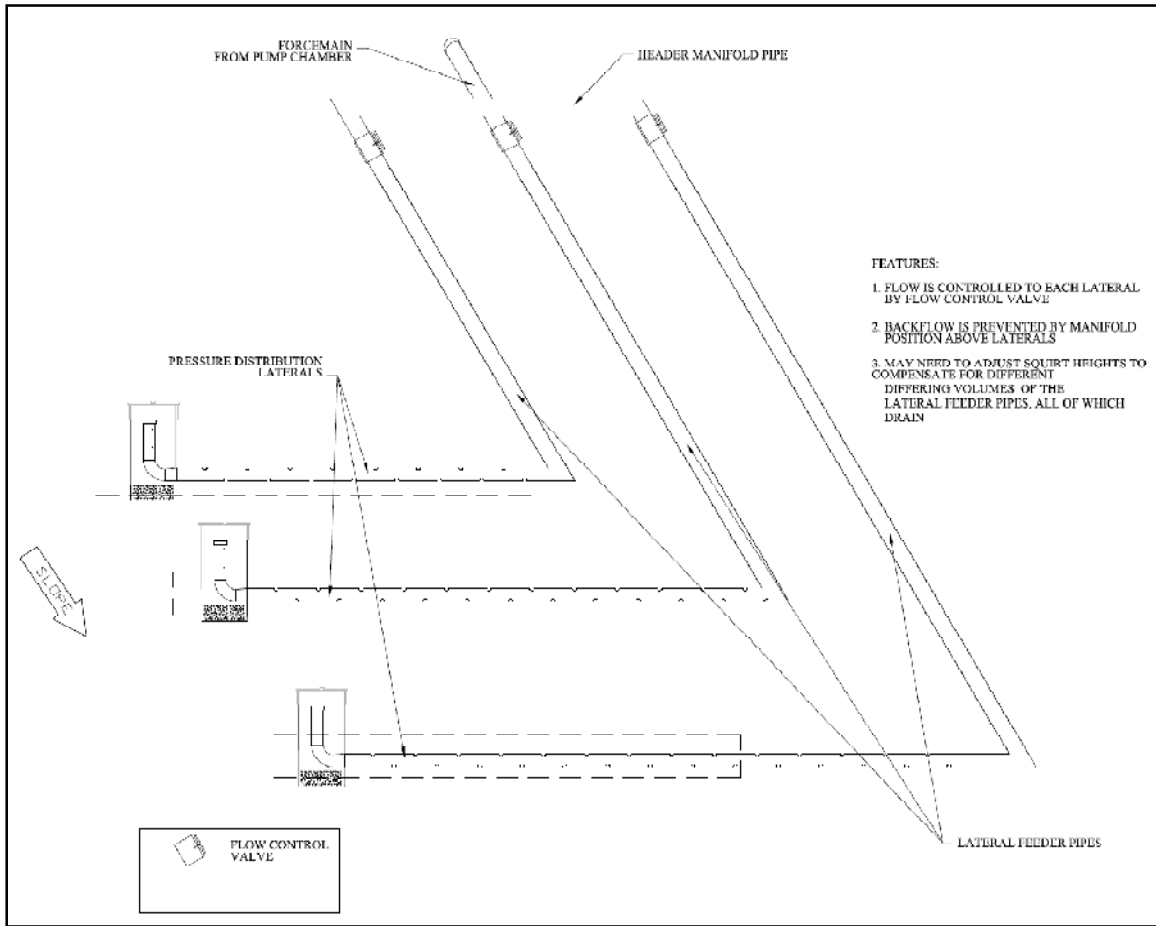

Note: Header location will prevent siphoning.

Feeder pipe sizing should take into account head loss. Small feeder pipes will reduce the problem of feeder pipe drain down. Sufficient slope could compensate for head losses.

To compensate for excess flow to lower laterals (due to feeder pipes), squirt height could be adjusted based on careful design. At install this could be tested by collecting and measuring volume dosed at each lateral's test orifice.

**Figure 3-19 Short Downslope Header Manifold, with Check Valves.**

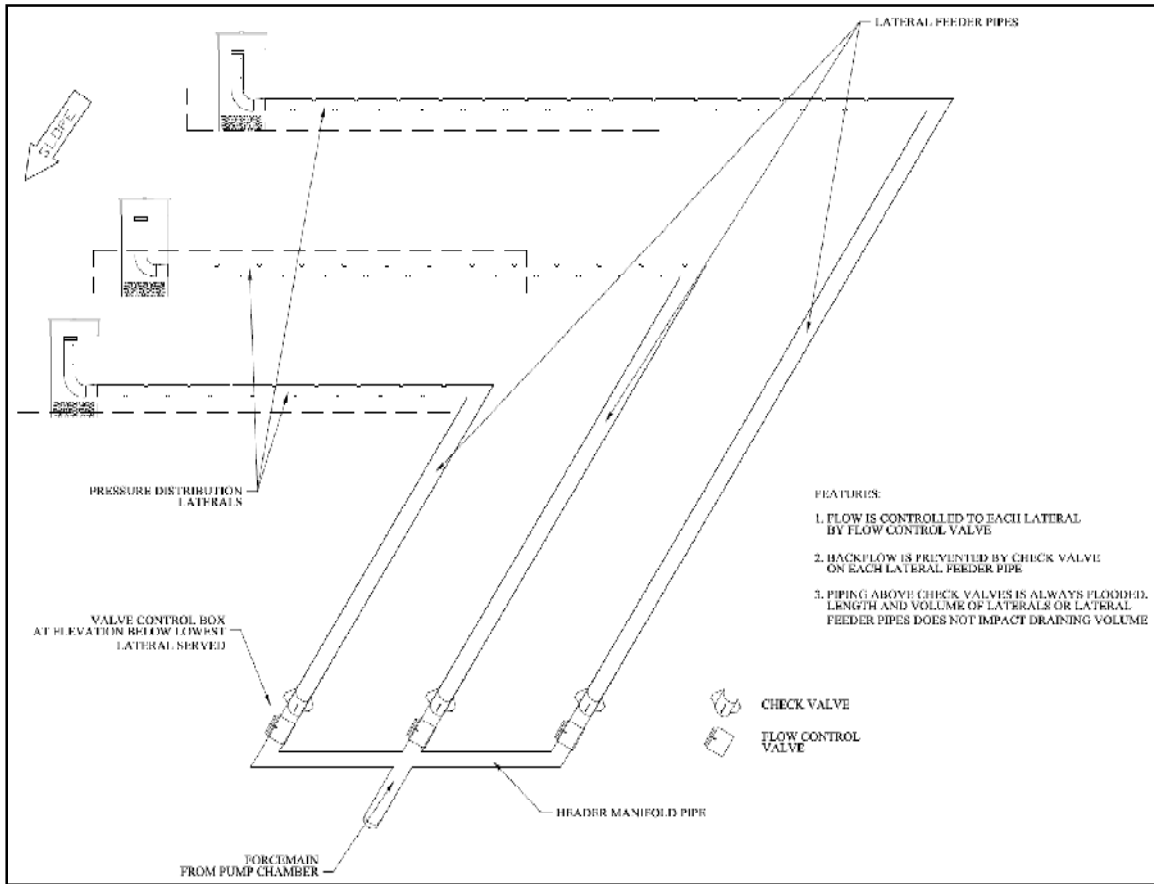

Where check valves are used these should be accessible for service. If the valve is needed to be removed for service of the mechanism, check valves should be installed with unions to permit cleaning.

Where flow control is needed to balance laterals on a sloping site or where laterals are of differing lengths, this is best achieved by the use of orifice plates, diaphragm valves or globe valves. Where orifice plates are used, the plates should be removable for service and orifice size should be clearly recorded.

***Dosing and Distribution Criteria***

The HLR selected from Part 2 is based on the long-term acceptance rate of the infiltrative surface. In order to address the performance objective of maintaining unsaturated conditions as much as possible it is also important to select a suitable instantaneous (or dose) loading rate (called the “hydraulic application rate” or HAR). See Appendix Q for discussion and references.

Based on soil type, select type of dosing and minimum dose frequency from Table 3-6:

**Table 3-6 Minimum Dosing Frequency**

DOSING FREQUENCY (MINIMUM) FOR TYPE 1 EFFLUENT LOADING RATES	SOIL TYPE
Timed dosing	Coarse sand, gravels, sand mounds etc.*
4 × per day	Medium sand, fine sand, loamy sand
2 × per day	Sandy loam, Loam, Silt Loam, Clay Loam*
4 × per day	Well structured sandy Clay, silty clay or clay*

**\*Note:**

Where clay content is in excess of 40% or where clay minerals in soil are expansible, timed dosing should be used.

More frequent small doses are always preferable.

Where treated effluent is applied at rates higher than those for Type 1 effluent, dosing should be designed to maintain unsaturated conditions and to discourage saturated flow below the infiltrative surface. For demand dosing in these cases, it is recommended that the Type 1 dosing frequencies be doubled.

**TIMED DOSING**

Timed dosing systems should be designed to dose at least 9 × per day with average flow (18 × per day at Daily Design Flow), for Type 1 effluent, where possible. This will be facilitated if the distribution network does not fully drain between doses. Dose as small a volume as possible.

Dose frequency could also be designed based on water holding capacity of the receiving soils (needed in certain cases for sand mounds and similar technologies) (linked standard). See Appendix Q.

Timed dosing should only be designed and commissioned by APs educated and competent in the design and installation of timed dose pressure distribution systems.

**DISTRIBUTION**

Distribution is considered to be uniform when 80% or more of the dose is delivered at full system pressurization. This is normally achieved when the dose is greater than or equal to 5 × the draining volume of the distribution network (i.e., the part that drains at the end of the dose).

This may be difficult to achieve where dose frequency exceeds 4 × per day at the Daily Design Flow and the laterals and manifold drain. In this case, the planner/designer could consider reduction to 60% or more of the dose being delivered at full pressurization.

Possible strategies to improve distribution include:

- carefully locating lateral drain holes and/or sloping lateral piping a maximum of 1% proximal to distal. Do not slope lateral trench bases, particularly in soils of loam or lower permeability;
- higher than minimum squirt heights;
- centre manifold design; and,
- non draining manifolds.

### *Zones*

The pressure distribution network could be split into zones to reduce pump and forcemain size. This could be achieved by alternating pumps and forcemains, solenoid valves or by distribution valves. Alternating siphons could also be used.

Where valves are used, head loss and needed flow should be taken into account in design.

### **3.7.7.3 PUMP TANK AND EFFLUENT PUMP/SIPHON DESIGN CONSIDERATIONS**

Follow relevant provisions of tank systems, in Section 3.6 (linked standard).

The pump tank should be preceded by an effluent filter except where pre-treatment is a treatment plant that, by design, will not discharge suspended solids larger than  $\frac{1}{16}$ ".

Within the pump tank, the pump could be housed within a screened vault to provide secondary filtration, in which case the vault should be readily accessible and removable for cleaning and the filter and filter mesh size should meet the standards for effluent filters.

Secondary effluent filtration could also be provided by a filter installed after the pump, which should meet the standards for effluent filters.

See Figure 3-20 for a pump tank nomenclature.

**Figure 3-20 Pump Tank Nomenclature: Showing Piping Layout Suitable for Areas Where Heavy Frost Is Not Encountered.**

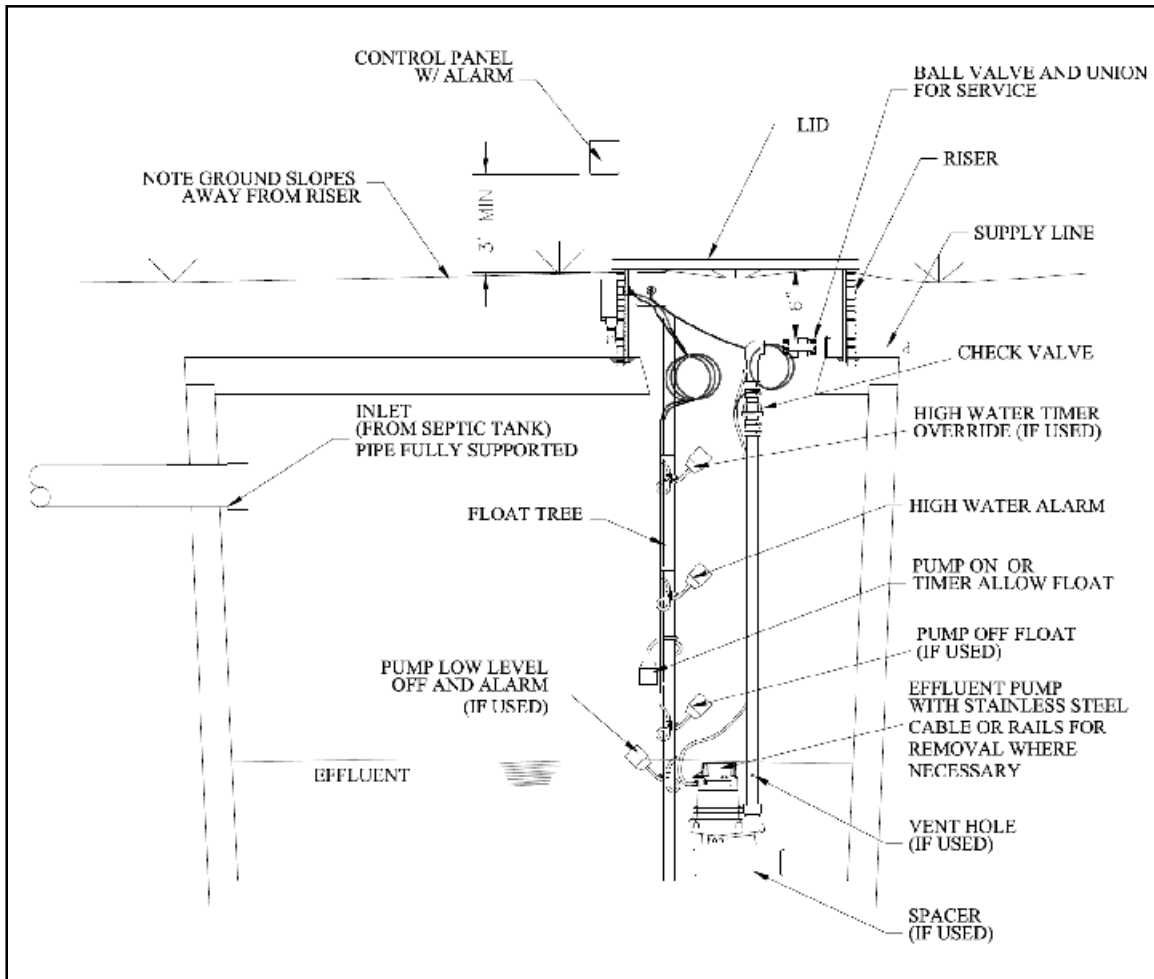

In cases where a supply line exiting as shown in Figure 3-20 will freeze, loop supply line back down from riser and exit at greater depth.

### *Pump Tank Sizing*

For pump tank sizing worksheet see, Appendix P. This includes a pump tank and float setting worksheet.

The type of pumping configuration that will be used determines tank sizing. Guideline volumes for chamber selection are set out in the following sections.

The working volume of a pump tank is from the inside bottom of the tank to the invert of the inlet pipe. Where the pump tank is installed at an appropriate elevation (use worksheet in Appendix P) in relation to the preceding tank (for example, a septic tank), then the alarm reserve volume could include the depth from the invert of the inlet to the underside of the tank lid, as long as the valve and union is accessible above that level

#### DEMAND DOSING PUMP TANK VOLUMES

Guideline minimum size/working volume = 1 day Daily Design Flow. See Figure 3-21 for terminology.

Reserve volume (above pump on float to alarm float on) a minimum of 15% of Daily Design Flow.

Alarm reserve volume (above alarm float on, to maximum permitted effluent level) a minimum of 50% of Daily Design Flow. This should permit dry access to pump disconnect union and valve, etc. for service.

*Note:*

Where a pump tank forms part of a treatment plant, the alarm reserve could include surcharge in the treatment plant. In this case the treatment plant manufacturer should ensure that the plant provides a minimum of 50% of the Daily Design Flow alarm reserve capacity.

Where system serves in a location where water supply is available during a power outage, or where service may take longer than one to two days, larger alarm reserve volume should be used, a minimum of one day DDF.

If it is necessary to drain back to the pump chamber (normally only to prevent freezing), the drain back volume should be added to the dose volume in sizing the pump chamber; therefore, the chamber will be larger. See pressure distribution design worksheet in Appendix P.

**Figure 3-21 Schematic of Demand Dosing Terms**

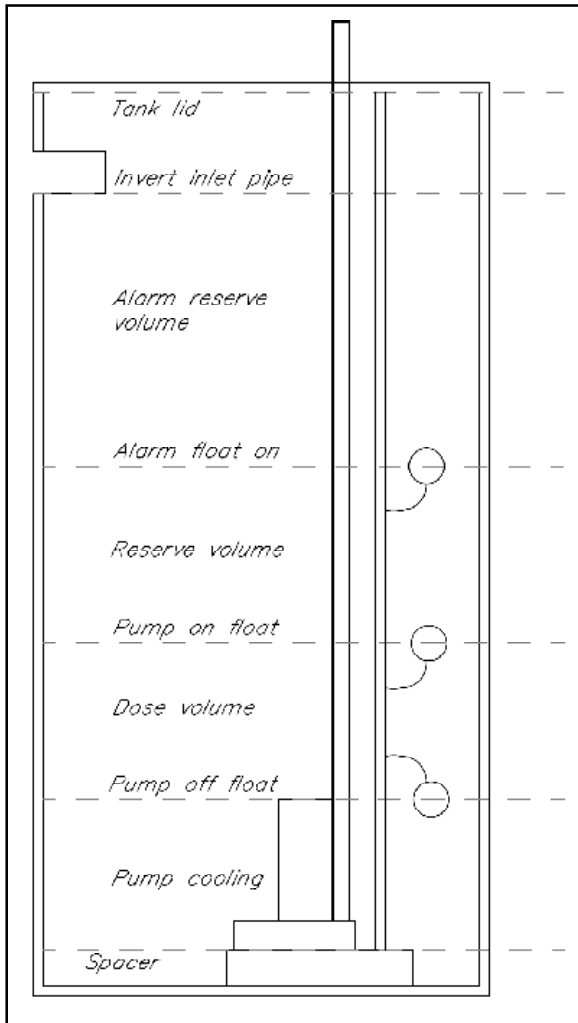

**TIMED DOSING PUMP TANK VOLUMES**

Guideline minimum volume =  $2 \times$  the Daily Design Flow for systems under 3,636 L/day (800 IG/day) Daily Design Flow. See Figure 3-22 for terminology.

This could be reduced in the case of systems where the flow is pre-equalized (for example, from a timed dosed pre-treatment system).

Timed dosing systems are intended to equalize flow peaks and ensure relatively even distribution throughout the day. This is achieved by use of a timer with set pump on and off periods. In some cases the dosing regimen can include a “lag” event which increases dose frequency to address peak flows.

To activate the timer and start timing a dose interval, there should be enough effluent in the tank to permit a full dose, this is normally termed the “timer allow volume,” and the timer allow float is located by this volume above the pump redundant low level off float/low level alarm float.

To equalize flows, a larger reserve volume is needed above this float. This can be from 0.67 to  $1.5 \times$  the Daily Design Flow. Where flows are pre-treated by a system that includes flow equalization (for example, an intermittent sand filter), this volume could be lower.

Alarm reserve volume design considerations are as for demand dosed systems above.

**Figure 3-22 Schematic of Timed Dosing Terms: Showing Example of Tank with Lag Float**

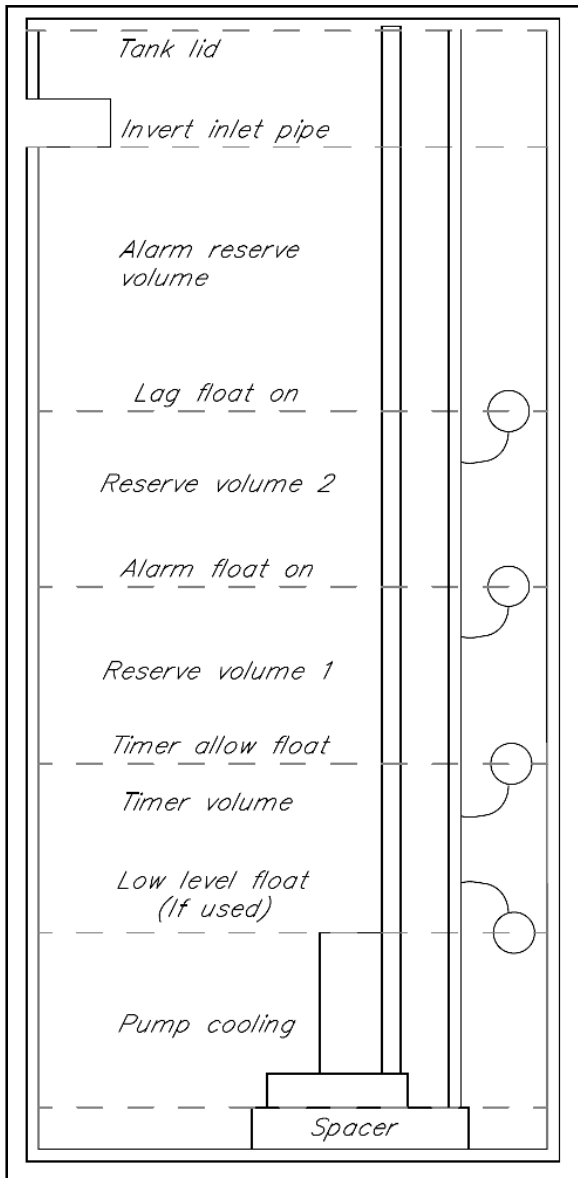

**Siphon Systems and Floating Outlet Devices**

Siphons and floating outlet devices are only suitable for demand dose systems.

Since adjustment to siphon trip level is limited, the correct pump tank size should be used to match the siphon.

After the high level alarm activates, siphon vaults should include an alarm reserve volume of 50% of DDF for systems with overflows, or 100% of DDF for systems without overflows.

Siphon transport line design should address proper venting and should take steps to avoid air binding.

Where siphons are used to dose pressure distribution systems or pressure manifolds, they should be designed to properly pressurize the system and achieve proper distribution. This will require the selection of a device with suitable flow characteristics and suitable pipe design/layout so that effluent backs up in the transport line and provides the required head at the field or manifold. It will also require a calculation of time for pressurization to confirm adequate time at full pressurization. The design should include all calculations and details required to ensure these requirements are met.

#### **3.7.7.4 PRESSURIZED DISTRIBUTION SPECIFICATIONS AND INSTALLATION CONSIDERATIONS**

##### ***Trench Criteria***

Follow relevant provisions of trench systems, Section 3.7.3 (linked standard).

Chamber systems used for pressure distribution on soils with textures finer than loamy fine sand should have their basal area covered with a minimum of 100 mm (4") of C33 sand or equivalent to reduce the risk of soil capping/crusting.

On sloping sites, there is a risk of effluent concentrating in the manifold and/or forcemain trenches and, in some cases, this may even lead to effluent flowing back down the forcemain trench towards the pump chamber. During installation, care should be taken to prevent this. Techniques include: shallower excavation for the manifold trench, clay or Bentonite plugs in the trenches and separation of the lateral trenches from the manifold trench.

##### ***Orifice Orientation and Orifice Shields, Cleanouts and Valves***

Orifice drilling is critical to system flow rate, the drill should be sharp and a new bit is recommended. The inside edge of the hole should be sharp and swarf should be removed by hand, not with the drill bit.

Orifices could be installed at the top or bottom of the pipe.

Crown orifice orientation (12 o'clock) provides the quickest pressurization of system. Where all orifices are in crown orientation and the lateral pipe is well levelled, effluent will remain in the pipe between doses. This may not be desirable in freezing conditions. In intermittent use situations, this could also lead to increased slime build up requiring more frequent flushing. Standing water in the laterals may also attract plant roots.

Invert orifice orientation (6 o'clock) will require an orifice at the 12 o'clock position located at the distal (far) end of the distribution line to bleed air and prevent pump failure.

6 o'clock orifice position will allow for drainage and prevent freezing in cold climates. The 6 o'clock orifice position could be used for one or more orifices per lateral or for all orifices.

Where orifices are installed in the 12 o'clock position and the lateral is to drain, install at least two 6 o'clock orifices for drainage. These could be installed approximately  $\frac{1}{3}$  of the lateral length from each end of the lateral. Where the lateral is sloping to the distal end, install a 6 o'clock orifice at that end.

All orifices, regardless of orientation in aggregate trench or bed systems, should be provided with orifice shields to improve distribution. Orifice shields should not retain pools of effluent where this may freeze.

As an alternative to the use of orifice shields for the 12 o'clock orifice position, the lateral could be sleeved with perforated 3" or 4" pipe. This has an added advantage in reducing root intrusion and permitting the pressure line to be removed and replaced if needed.

All forcemains, manifolds and laterals should be provided with cleanouts. The lateral cleanouts should be in access boxes or pipes, which should include drainrock or pea gravel sumps to collect spilled effluent. Where necessary, include vertical steel rod at cleanouts to allow for location of the cleanout.

Cleanouts with turn ups should be built using sweeps or 45° elbows to permit cleaning of the laterals.

In larger systems, cleanouts could be directed to a dedicated chamber system for regular flushing by flush manifold and individual flush valves. This strategy could also suit situations where frequent flushing will be needed.

Laterals can be provided with valves at the proximal end to permit flushing individually, which will improve the scouring of the pipe. Where the valves will be difficult to reach, install extension handles so that in all cases, handles or handle extensions permit access within 150 mm (6") of the surface or a large enough valve box to permit easy access to a stiff valve.

When teeing off the manifold, it is preferable to use a direct reducing tee rather than bushings (for example, a 2" × 2" × 1.25" tee) as this reduces head loss and gives less opportunity for solids accumulation in a place that cannot be flushed.

### ***Cold Weather Criteria***

In cold climates, protect all piping and water-filled components from freezing.

It could be necessary to orient laterals so that effluent drains out after the dosing period.

Manifolds may need to drain out, and in some cases forcemains may need to be drained back to the pump tank.

### *Pump Tank*

Follow the relevant provisions of tank systems in Section 3.6.

### *Effluent Pump*

All pumps should:

- comply with CSA and UL standards;
- be rated for the specific application;
- have corrosion-resistant impeller(s);
- have the pump inlet protected from debris that might enter the pump tank, either by built in legs or spacers, by installation in a shallow vault, by installation in a screened vault or flow induction tube or suitable pump spacer. Any method should provide stable support, protect the pump tank from damage and not obstruct the pump inlet or pump cooling; and,
- be provided with a pump removal assembly. Removal assembly should be designed to remove pump efficiently and safely (without entering the pump tank and without excessive exposure to effluent), be corrosion resistant and have corrosion resistant fittings. Access to the removal assembly should be within 150 mm (6") of the riser rim.

*Note:*

Where connectors or other components that should be accessed are 45 cm (18") below the riser rim (as has been standard practice); then they are not reachable without presenting a confined space entry hazard (proximity of the face to the plane of entry and surrounding area where the presence of gases may be present) and violates Workers' Compensation Board health and safety standards.

### *Plumbing Criteria*

Follow relevant provisions of pipe and collection systems in Section 3.5 (linked standard).

Where a check valve is provided to prevent forcemain drain back, a shutoff valve should be provided for service.

Pump riser main should be equipped with unions or equivalent for quick disconnection:

- maximum 150 mm (6") below the pump tank access lid;
- positioned at the top of the pump assembly on the pump side of the check shutoff;
- be accessible and above maximum effluent level in pump tank; and,
- where this would lead to freezing, insulation to be added above lid.

A pressure test port (Schraeder valve) could be installed in the pump discharge line to permit pressure testing.

When the discharge point is lower than the pump, it is necessary to prevent siphoning of the pump chamber to the field. For example:

- the pump could be fitted with a vacuum breaker (installed above maximum effluent level in pump tank);
- use a pump discharge orifice;
- pressure sustaining valve installed on the forcemain (spring type check valve); and,
- solenoid/motorized valve on the forcemain.

An orifice can also be used in the discharge assembly to allow for pump priming, drain back or to prevent siphoning. If an orifice is open during pump cycling then that orifice flow should be included in calculations for pump sizing in pressure distribution design. See worksheet in Appendix P.

#### *Float Switch/Pressure Sensor/Ultrasonic Sensor Criteria*

Float switches, pressure sensors, ultrasonic sensors etc., should be mounted on a separate bracket or float tree so that they can be easily replaced and/or adjusted without removing the pump or entering the pump tank. Access for removal should be within 150 mm (6") of the pump tank access riser rim.

#### *High Level Alarm*

The pump tank should be equipped with a high liquid level alarm that is both audible and visual. The alarm should:

- be placed in a conspicuous location, preferably exterior (Example: utility room, back entranceway, etc.);
- be audible so as to be heard within a 30 m (100') radius or on the main floor of the building that the system serves;
- be wired separately from the pump;
- be suitably rated for the environment the alarm panel should be mounted in;
- be powered by a separate power circuit from the pump;
- not activate the pump; and,
- preferably be of a type that needs manual reset.

#### *Low Level Alarm*

A low level alarm and pump redundant low level off float will protect the pump from damage in case of failure of the main float switch, and will also detect pump chamber leakage or siphoning. These are needed for timed dose systems, and desirable for demand dose systems.

### ***Electrical Criteria***

Electrical wiring must comply with B.C. Electrical Codes for wet and corrosive locations for all new installations. In the case of repair, wiring must be installed based on the applicable codes.

Electrical work must be performed by a qualified registered electrician, or the homeowner, as described in the *Safety Standards Act*, Electrical Safety Regulation, and Section 4 to 18; and must meet the requirements of all parts of the Canadian Electrical Code (current edition). Work done by either party must be done with a permit.

Cable or conduit penetration through riser or tank should be gastight and watertight. Conduit leaving the pump tank should be sealed gas and liquid tight to prevent gas and liquid reaching the control panel or junction box.

Electrical connection boxes and control panel should be positioned for easy access, maintenance and adjustment criteria and should include a disconnect. Protect from weather. Use only outdoor rated connection boxes and control panels for all outdoor applications.

Control panel or system should be equipped with cycle counters and elapsed time meters or suitable datalogger in order to provide a record of system flows. Where a flow meter is provided as part of the system, this is not needed.

### ***Siphon and Floating Outlet Systems***

Follow relevant provisions of tank systems in Section 3.6.

Siphon tank should have a cycle counter to detect trickling failure. A high level alarm is also needed. Where alternating siphons are installed there should be cycle counters at each field to detect failure of either siphon.

Siphons could be installed with an overflow, which should only overflow after the alarm is tripped.

Siphons are sensitive to air binding and transport lines should be specified and installed to prevent this. Avoid radical slope changes, dips or humps in pipeline. At time of installation additional venting may need to be installed.

For dosing to a gravity system, a transport pipe one size larger than the siphon size should be used.

Siphons should be securely mounted because settlement of the siphon tank will cause serious difficulties with a siphon system.

### ***Commissioning — Testing***

Perform a comprehensive test of all components and distribution pressure test to verify that the distribution system is in proper working order prior to final backfilling, grading and placing into operation.

Record float settings. Record pump chamber depth per gallon or litre (example mm per L) and also write this on the inside of pump tank lid or in control panel (including units).

System should be flushed with a minimum of two pipe volumes prior to testing. This should be done sequentially, starting with the forcemain, then the manifold, then the individual laterals.

Perform a residual head pressure test to verify proper residual head height. This is most accurately done with tubing or clear pipe, particularly if there is any wind.

Where system contains effluent, care should be taken to avoid contaminating the ground surface with effluent.

Record squirt height or residual pressure above pipe centerline.

Residual head height variation from proximal to distal end of distribution network should be not greater than 15%, and no more than 10% proximal to distal on each lateral.

To check for drain down to lower laterals (where a problem is suspected), it is possible to collect effluent volume from a test orifice at each lateral end and compare volumes to check these are within 15%.

Record pump run time for dose, or drawdown for timed dose systems. Ensure correct dose is delivered.

Record pump flow rate and pump run amperage at commissioning; pump amperage should only be recorded by an AP who is not an electrician by use of a non-contact meter (for example, a clamp on meter) or installed meter. Flow rate could be measured by a flow meter or by drawdown and calculation.

All commissioning details should be included with the maintenance plan for the system.

### 3.7.7.5 PRESSURIZED DISTRIBUTION MONITORING AND MAINTENANCE CONSIDERATIONS

Follow relevant provisions of trench systems, Section 3.7.3.

#### **Pump tanks:**

- inspect tanks as applicable per septic tanks, Section 3.6.1.5;
- visually inspect all electrical connections for signs of corrosion, black deposits on copper items that may indicate leakage of sewer gases and physical deterioration;
- ensure that high level or other alarm(s) are in working order;
- ensure that float switches are performing properly;
- visually inspect control panel box for watertightness, condensation or corrosion;
- ensure that timer or control relays are functioning and that control panel is functioning to design;

- inspect float levels and drawdown time (demand) or drawdown per dose and timer function (timed systems);
- where a flow meter (installed or ultrasonic) is available, check and record dosing flow rate and compare to commissioning record;
- where a pressure test port is available, record pressure during a dose event;
- record pump run amperage. Pump amperage should only be recorded by an AP who is not an electrician by use of non-contact meter (for example, a clamp on meter) or installed meter. Use of a flow meter is an alternate method of assessing pump performance, and may be more easily used to analyse pump wear;
- record counter and pump run time information and analyse to determine system flows. Check run time against dose time multiplied by pump starts. Due to inflow events on demand dosed systems, this will only provide an approximate check;
- for timed dose systems, record pump cycle counter, lag/override counter (if used) and low and high level alarm log. Analyse information in relation to design flows. Check pump drawdown for one dose and relate to commissioning tests. Where pump run time meter is installed, check run time is as expected;
- inspect all plumbing fittings and connections;
- check that anti siphon air valve, orifice or other provision is operating effectively to prevent pump tank contents siphoning to field between doses;
- ensure that all components are operating as per design;
- the dose chamber may fill due to flow continuing during pump malfunction or power outages. The pump chamber should be pumped by a licensed pumper before pump cycling begins, or other measures should be used to dose the conventional soil absorption component with only the proper amount of effluent; and,
- at 3 – 4 year intervals, or as needed based on monitoring, vacuum and clean out the tank. The pump and floats should also be washed down at this time, which will assist in assessing their condition.

### **Siphon Systems**

- A siphon system should be monitored for trickling failure. If this is found to have occurred, the cause should be determined.
- As even a momentary blockage of the sniffer tube may cause the siphon to enter trickling mode, the siphon chamber should be kept clean and leaves or other floating debris should not be left in the chamber.
- At 3 – 4 year intervals, or as needed based on monitoring, vacuum and clean out the tank. Wash down the bell and interior surfaces.
- Check the bell to ensure it is sitting level.

### **SWIS:**

- follow appropriate items per gravity distribution systems in Section 3.7.4 (linked standard).
- perform residual pressure test and record “squirt height” or distal pressure; compare this to commissioning record and to previous maintenance records. Use same size and type of orifice used at commissioning:
  - avoid contaminating site with effluent on the surface, direct flow back to trench or use clear pipe/tubes,
  - check for equal distribution and for drain back to lower laterals, if the latter is occurring evaluate check valves or other design feature which was intended to prevent this;
- periodic clean out of laterals, when residual head falls more than 25% below commissioning records;
  - note that if tubes or clear pipes are used for testing a 10% variation may be detectable;
  - when flushing laterals, note the extent, colour and consistency of any solids discharging from the cleanouts of each lateral and note this between each site visit;
  - when flushing laterals, the liquid that is flushed out of the laterals should be directed back into the distribution trench or bed. The liquid could also be directed into an acceptable container and disposed of properly; this is preferable where there are significant solids;
  - if necessary, the laterals can be cleaned;
  - cleanout access should drain rapidly after pump switches off, (where these are in the dispersal trench or bed). Where this is not the case the cause should be investigated;
  - hydrogen peroxide could be used to assist lateral cleaning. Avoid excess Hydrogen Peroxide which may damage soil structure;
- if lateral valves are closed to flush laterals, reset distal pressures to ensure even distribution per design and commissioning records. Record squirt heights or pressures; and,
- make a dosing application rate, drawdown and/or volume test, and compare to commissioning data.

### **3.7.8 Rock Pits — Drywells**

Rock pits/drywells as a dispersal unit are not considered to meet the base performance standards of this manual, and therefore it is strongly recommended that these not be used.

### 3.7.9 Seepage Beds

#### 3.7.9.1 SEEPAGE BED DESCRIPTION AND PRINCIPLES OF OPERATION

Seepage beds are also known as infiltration beds. See Figure 3-23.

**Figure 3-23 Seepage Bed Pressure Dispersal Typical Cross Section**

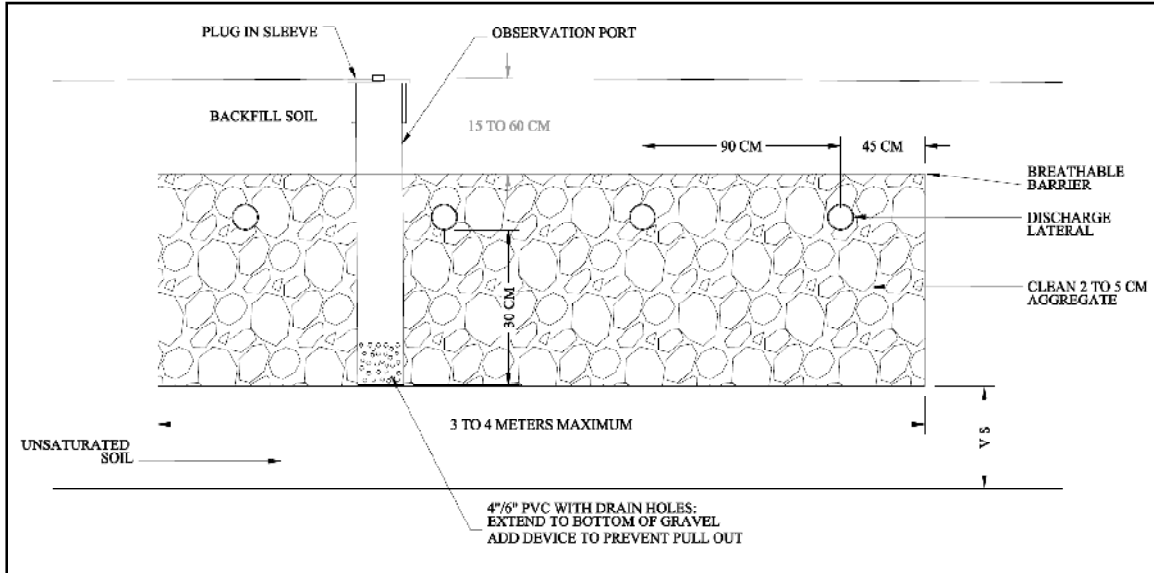

#### 3.7.9.2 SEEPAGE BED DESIGN CRITERIA

Pressure distribution is recommended for seepage beds.

Follow relevant provisions of gravity or pressure systems to design gravity distribution systems (Section 3.7.4) and pressure systems, (Section 3.7.7) (linked standards).

Provide detailed design notes, specifications and distribution system layout plans.

##### *Site Criteria*

Soil texture should be coarse sand, fine sand, loamy sand, silty sand or sandy loam, with percolation or Kfs values in agreement with these soil types per Hydraulic Loading Rate Table 2-8. Gravity systems should not be used on coarse sand or fine sand.

Slope of site should be less than 15%.

Seepage Beds if used on sites not meeting these criteria should be designed or the design reviewed by a Professional.

##### *Bed Sizing*

Seepage beds, as discussed in Part 2, need reduction of the soil HLR by a factor of 1.35.

**Example:**

**Bed area:**

Bed infiltrative bottom area needed =  
 (Daily Design Flow divided by hydraulic loading rate (HLR)) × 1.35:

*OR*

Infiltrative area = Daily Design Flow ÷ (hydraulic loading rate × 1.35)

**For bed length and width:**

Minimum length of bed = infiltrative area ÷ Linear Loading Rate,  
 maximum LLR 124 L/m/day (8.33 IG/ft/day)

Width of bed: Narrower of the widths provided by LLR calculations or 13'

Design length of bed = infiltrative area divided by this bed width

***Bed Dimensions***

Should not be greater than 4 m (13') in width and, where dosed by gravity, the gravity fed laterals should not exceed 30 m (100') in length. Where the gravity system is not dosed, lateral length should be restricted to 15 m (50').

The lateral spacing should not be less than 0.9 m (3') and not greater than 1.2 m (4') for gravity distribution.

The bed's outer edge should not be less than 460 mm (18") from centre of discharge lateral pipe.

**3.7.9.3 SEEPAGE BED SPECIFICATIONS AND INSTALLATION CONSIDERATIONS**

Follow relevant provisions of trench systems in Section 3.7.3.3.

Pressure or gravity distribution systems per relevant provisions of gravity systems in Section 3.7.4.3 and pressure systems in Section 3.7.7.4.

Bed should be level across its width and length, be constructed parallel to the slope and be as long and narrow as possible. Gravity laterals should be centre fed.

The bed should have not less than 223 mm (9") of aggregate depth between point of discharge and bed bottom infiltration area and should have a 50 mm (2") aggregate cover above distribution pipe. 305 mm (12") of aggregate below the pipe will provide for extra storage.

For monitoring, the bed should be equipped with a minimum of two effluent infiltration monitoring wells located at proximal and distal (near and far) ends of the outermost lateral runs.

The aggregate should be covered with a breathable, water permeable, geotextile material or equivalent (for example, untreated building paper, straw) and should have a soil cover of not less than 150 mm (6"). See Geotextile specifications in trench Section 3.7.3.

The sites should be graded to provide drainage away from bed surface area. An upslope swale could be necessary to divert surface water from the area.

Seed or sod the site immediately after construction to prevent erosion.

### ***Bed Aggregate***

Bed aggregate to conform to trench criteria.

Any geotextile used for aggregate cover should follow trench criteria.

#### **3.7.9.4 SEEPAGE BED CONSTRUCTION**

Follow relevant provisions of Trench systems and gravity or pressure distribution systems sections.

Finished distribution area should be graded so that rain or ground water can drain away from the site. This could require use of an upslope swale.

Seed or sod the site immediately after construction to prevent erosion.

#### **3.7.9.5 SEEPAGE BED MAINTENANCE AND MONITORING CONSIDERATIONS**

Follow relevant provisions of trench and gravity or pressure distribution sections.

### **3.7.10 At Grade Bed and Raised Bed Systems**

#### **3.7.10.1 AT GRADE BED PERFORMANCE STANDARDS**

The intent of an at grade or raised system is to address shallow vertical separation by making maximum use of native soils.

Where an at grade bed is used the bed is intended to distribute effluent evenly to the surface of the native soil, which is treated by tillage or scarifying to encourage unsaturated flow from the bed to soil and thus to improve dispersion and treatment.

Design, installation and maintenance should ensure that this intent is met.

### 3.7.10.2 AT GRADE BED DESCRIPTION AND PRINCIPLES OF OPERATION

An at grade bed is an aggregate bed placed on prepared topsoil of a site, into which effluent is distributed by pressure. This may be seen simply as a sand mound without the sand; however, unlike a sand mound, the bed on a sloping site is not installed level across its width, but rather follows the ground slope. (See Figure 3-24.)

Raised bed systems are built as for sand mounds, but with less than 12" of sand below the bed. In these cases the sand fill is used to level the bed across its width as for a sand mound.

The technique is suitable for sites where effluent should be applied at grade to provide adequate vertical separation. An alternative is to use at grade trenches with fill, which has the advantage of more effectively distributing the effluent over a larger area of the topsoil, as well as being more efficient in the use of fill. Very steeply sloping sites are not suitable for this technique.

Pressure distribution should be used for the at grade bed and for any raised system (linked standard).

**Figure 3-24 At Grade Bed Typical Cross Section**

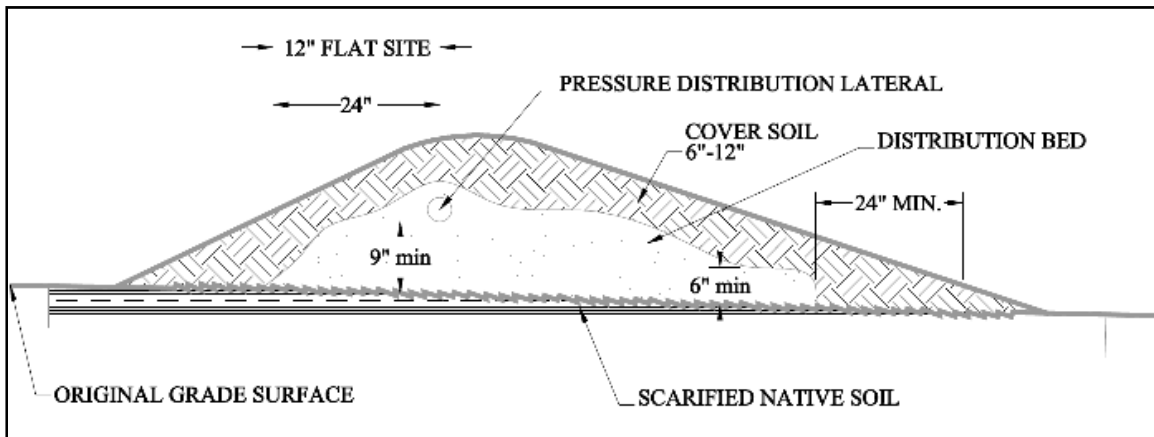

### 3.7.10.3 AT GRADE BED DESIGN CONSIDERATIONS

Not for use on slopes >25%.

Where soils are of low permeability, care should be taken to avoid toe breakout on sloping sites and it could be necessary to use a raised bed system (with a bed level across its width) to reduce flow concentration at the downslope bed edge.

Vertical separation is as for trench or bed systems. Horizontal setbacks are calculated from the edge of the aggregate bed.

At grade bed design is generally similar to sand mound design, based upon LLR consideration to determine bed length, followed by use of HLR to determine effective bed width based on the Area of Infiltrative Surface. Selection and application of an

applicable LLR should form part of at grade bed design. Effective bed width is not to exceed 3 m (10').

For flat sites the actual bed width is equal to the effective bed width.

For sloping sites, actual bed width is determined from the effective bed width, plus 0.6 m (2') extra width.

Overall width and length (including cover soil) will be the actual bed width and length plus a minimum of 3 m (10') added length and width to provide for soil cover and minimum separation from bed to surface.

On sloping sites, surface water flow from uphill should be diverted around the mound in a swale.

The bed should be installed following the contour, and should be level along its length (although the bed could be broken into sections at differing elevations).

Where there are many trees and/or boulders, the area taken up by these should be subtracted from the effective area when calculating the minimum area of infiltrative surface.

For pressure distribution system design follow Section 3.7.7 (linked standard).

At grade or raised trenches are designed per applicable trench system design considerations, see Section 3.7.3.2 (linked standard).

Provide detailed design notes, specifications and distribution system layout plans.

### ***Contour Construction and Special Instructions for Concave Slopes***

The bed is placed along the contour, and where the contour is curved to give a concave (from side to side) slope, the effective cell length is given by the distance between the furthest points along the contour line of the downslope edge of the concave distribution cell. Where the deflection from a straight line exceeds 10%, this technique should not be used.

For diagram and calculation of effective bed length, see sand mound Section 3.8.

Where only part of the bed is concave, that part is separated for this calculation per the diagram.

This need not be applied where subsurface water flow is primarily vertical and/or vertical separation is over 1.83 m (72").

### ***Bed and Pipe Network***

On a sloping site, the distribution network starts 0.6 m (2') from the uphill edge of the bed and no pipe should be placed in the lower half of the bed. On flat site, it should be centered in the bed. The network is placed in the raised portion of the bed. For a flat site,

the distribution pipes are laid to ensure a minimum of 0.3 m (12") from pipe to edge of bed.

Minimum of 150 mm (6") aggregate below distribution network level (minimum at bed edges, 230 mm (9") minimum below pipes), 50 mm (2") above, plus 150 – 305 mm (6 – 12") soil cover. Cover the aggregate with graded filter or by geotextile as for sand mounds. Soil cover depth is the depth after settling.

Soil cover should be sloped from centerline of bed (as for mound systems) to provide positive drainage. Minimum slope from centre to edge should be 150 mm (6"), resulting in deeper soil cover (depending on bed shape) over bed centre.

To reduce opportunity of effluent surfacing, cover soil should extend at bed ends and up and downslope a minimum of 0.6 m (24") horizontally from the edge of the bed (as for sand mounds). The addition of 3 m (10') to length and width will normally ensure this.

Where soils have large macropores, use of a 100 mm (4") sand layer below the bed (per trench technique) is strongly recommended. This is not considered sand fill in terms of a raised system and the bed need not be levelled.

Observation ports: Minimum two along downslope edge of bed  $\frac{1}{6}$  of length from ends, to be installed per trench system standards. For flat sites, install at opposite edges of the bed at same spacing.

Network design per sand mound design and pressure distribution design.

For dosing, design follow standards for pressure distribution systems (linked standard) (*Section 3.7.5.2*).

#### 3.7.10.4 AT GRADE BED SPECIFICATIONS AND INSTALLATION CONSIDERATIONS

Maximum 0.36 m (4 ft<sup>2</sup>) per orifice, a minimum of one orifice per 610 mm (2') linear of bed.

Aggregate should meet minimum standards for trench systems (*Section 3.7.3*) or to be pea gravel, 3 – 12 mm stone ( $\frac{1}{8}$  –  $\frac{1}{2}$ "), washed and with <1% by weight passing the #200 sieve. Minimum hardness 3 on the Moh's scale.

Where pea gravel is used there may be a higher risk of biomat accumulation and soil cover should be kept to minimum. Consideration should also be given to reducing the hydraulic loading rate in soils of lower permeability.

Cover soil and cover soil installation to meet standards for sand mound *Section 3.8.1.4* (linked standard). Side slope for cover soil maximum 2h: 1v, 3h: 1v is more suitable for mowing.

Geotextile (where used) to be non-woven and to meet the standards of trench *Section 3.7.3* (linked standard).

Follow relevant installation considerations for sand mounds and pressure distribution systems.

Vehicles or heavy animal traffic should not be permitted on the finished system. This consideration could also apply to the receiving area for some sites.

### ***Construction Considerations***

Site preparation and site conditions constraints are as for sand mound construction (Section 3.8.1.4, and Appendix H). Preparation (including scarification) of the basal area of the bed (or trench for at grade trenches) is critically important.

Trees in the bed area should be cut at grade per sand mound. Contour scarification of the basal area is strongly recommended. Follow considerations for sand mounds (linked standard).

Install minimum 150 mm (6") of aggregate on bed area immediately after scarification. Do not drive equipment on the bed or the area downslope of the bed.

Protect bed and receiving area from traffic and construction impact.

Follow relevant installation considerations for sand mounds and pressure distribution systems.

### **3.7.10.5 AT GRADE BED MAINTENANCE AND MONITORING CONSIDERATIONS**

Follow criteria for pressure distribution/trench systems as applicable (linked standard).

Prevent vehicle access, site disturbance, and soil compaction and maintain natural ecosystem in bed area and receiving area (minimum 4.6 m (15') around bed area on flat sites or 7.6 m (25)' downslope from bed on sloping site).

Where bed interface to native soil is ponding, the cause should be determined and rectified. This could include excess biomat accumulation due to poor oxygen infiltration through over compact cover soils, original poor basal area preparation and overloading (hydraulic and/or organic).

### **3.7.11 Pressurized Shallow Narrow Dispersal Trenches (PSND)**

#### **3.7.11.1 PSND PERFORMANCE STANDARD**

The intent of this technique is to apply effluent in very small doses as near to ground surface as possible, with uniform distribution in order to use the biologically active upper soil layers.

In order to achieve recommended performance; discharge rates should be equal per lateral and drain back to lower laterals should be prevented. Strict timed dosing is needed to permit this technique, and where areal loading rates are used the effluent should be

highly treated and this level of treatment should be assured. This system should only be used with timed micro dosing.

The surface of the field area should not be used or disturbed in order to avoid contact with effluent.

### 3.7.11.2 PSND DESCRIPTION AND PRINCIPLES OF OPERATION

Effluent (normally highly treated) is dosed at a very low per dose application (micro dosing) by timed pressure dosing to a modified trench system. The trench system is made up of narrow trenches, placed as close to the surface as possible.

The trenches can be made of a conventional aggregate and pipe style or chambers made of 12" PVC or other plastic pipe halved lengthwise and supported on 1" PVC pipe cross pieces. See Figure 3-25.

Due to the type of dosing, unsaturated conditions prevail and oxygen transport is maximized by the shallow placement and inter-dose rest periods, thus greatly reducing biomat build-up. Due to the unsaturated conditions, lack of biomat is not as problematic from a treatment perspective. The shallow placement encourages biological activity and treatment, and soil macro fauna play an important role.

The low impact caused by the trench systems and their flexibility to site conditions permits less disturbance of the soil structure, vegetation and roots, in turn leading to better opportunity for Evapotranspiration and improved in soil treatment. The reduced impact may also address owner's site priorities.

When used with highly treated (Type 2 10/10 effluent or Type 3 effluent) the field loading is calculated on an areal basis and trenches are spaced closer than normal (1.2 m (4') – 1.5m (5') being typical).

As with SDD systems, instantaneous loading in the trench is of great importance, and dose volumes (Hydraulic Application Rate) should be kept low to avoid local saturation and flow concentration/saturated flow. This is particularly critical where soils have large macropores or are highly permeable. Orifices should be spaced maximum 610 mm (24"), and are normally spaced 460 mm (18") to 610 mm (24") apart.

As with SDD systems this technique needs considerable care when used with Type 1 effluent to avoid biomat clogging the narrow trenches, and the system should only be used on well structured sandy loam or loamy sand soils with Type 1 effluent, and areal loading rates should not be used. In this case the area of infiltrative surface is determined as for any trench system, based on the trench basal area. With Type 1 effluent, since use of the half pipe technique does not provide aeration through the pipe walls, vent pipes should be used. These can be installed at the observation ports or separately and should be minimum one 100 mm (4") pipe per 6 m (20') of lateral, vent pipes should have inlets that prevent rain entering and be raised (minimum 305 mm (12")) and screened to prevent rodents, flies, etc. from entering.

As with any chamber system, where the half pipe technique is used sand bedding can be needed to prevent soil capping in soils with this tendency.

For soils with large macropores or coarse sands, gravelly sands and gravels sand-lined shallow narrow trenches should be used, with minimum 305 mm (12") of mound sand (or 610 mm (24") for very gravelly sands and gravels) below the trench, and this technique should only be used with highly treated effluent (Type 3 or Type 2 10/10).

This technique should only be used by APs educated and competent in the design and installation of shallow narrow drainfield systems. As in all cases, Type 3 systems must be designed and installed by a Professional as required by section 6 of the SSR.

**Figure 3-25 Shallow Narrow Drainfield Cross Sections**

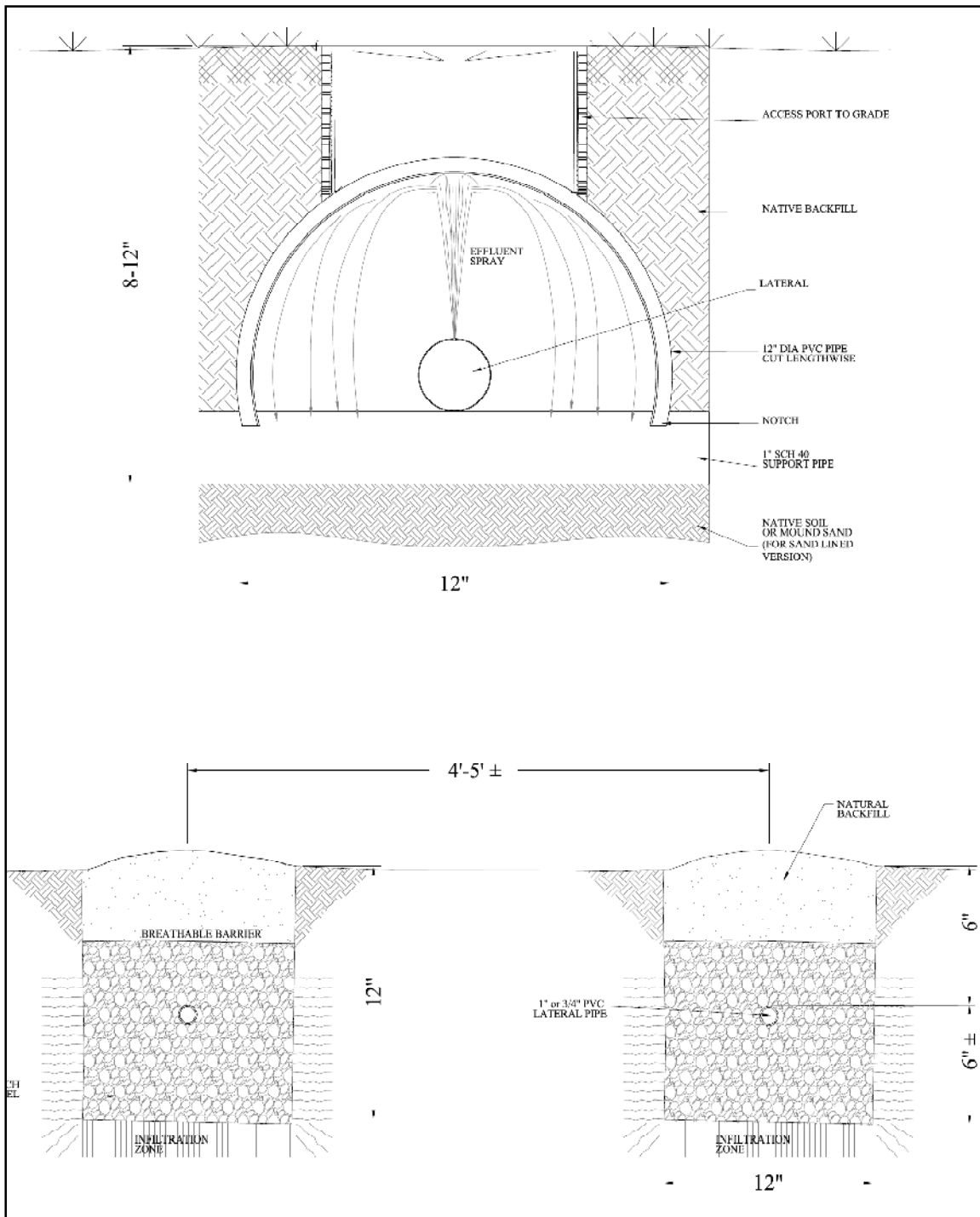

**3.7.11.3 PSND DESIGN CONSIDERATIONS**

Beyond the standards above:

As the technique relies upon maintenance of unsaturated conditions (for treatment) and upon provision of resting periods for reoxygenation (to prevent biomat build-up) timed

dosing with full equalization should be used. While a normal trench system has room for considerable internal equalization in an emergency situation, these trenches do not.

In order to address this performance standard, selection of an appropriate HLR should be accompanied by selection of the hydraulic application rate (dose volume).

Dosing is typically 2 to 3 times per hour. Dose volume should be calculated based on avoidance of local saturation during the application; this can be estimated by considering the water holding capacity of the soils for 610 mm (24") under the trench base. See Appendix Q. This could lead to an impracticably small dose volume, which in turn could necessitate reduction in the loading rate. This is particularly likely when areal loading rates are used with highly treated effluent.

Dosing at levels higher than the DDF should not be permitted, so any override or lag operation should not exceed the DDF and also should not increase the per dose volume.

Due to these dosing considerations, coupled with the need for shallow burial, this technique may be more easily applied where frost is not a concern.

System length should be determined by application of the LLR.

Type 1 or 2 effluent should be applied based upon trench basal area calculated from HLR.

Type 2 10/10 and Type 3 effluent can be applied based on areal loading rates for all suitable soils. However, due to dosing considerations the loading rates of Part 2 may need to be reduced.

Trench spacing standard 1.5 m (5') centre to centre, minimum 1.2 m (4') centre to centre. Short laterals will improve the ability to design for good distribution at small dose volumes.

#### 3.7.11.4 PSND SPECIFICATION AND INSTALLATION CONSIDERATIONS

Keep trench base 200 mm (8") to a maximum of 305 mm (12") below final grade. Trenches should be installed level, and level side to side. Do not over dig and refill, and do not over dig width of trench when using a half pipe system. Scarify trench base.

Follow relevant pressure distribution system considerations.

Avoid any unnecessary site impact: trenches could be dug by hand. Leave trees, etc. intact, taking care to remove or kill any that would have invasive roots (willow, aspen, bamboo etc).

Where half 12" PVC or other plastic pipe is used, lateral pipes are supported on pieces of 1" sch40 pipe at 1.2 m (48") OC and at each joint in the 12" half pipe. These also act as spreaders to support the 12" pipe, notches being cut into these spreaders to support the half pipe.

Access risers provide observation ports and are taken to grade in each 6 m (20') of pipe, with lid. If these are plastic valve boxes with lids, the lids should be clearly marked

“Sewer.” Cover joints, riser joints and ends with geotextile (per Trench Systems in Section 3.7.3). Any 6 o’clock orifices should have orifice shields.

Where trenches are used, aggregate to be 3 – 12 mm pea gravel ( $\frac{1}{8}$  –  $\frac{1}{2}$ " stone), washed and with <1% by weight passing the #200 sieve. Minimum hardness 3 on the Moh’s scale. All orifices with shields, 6 o’clock orifices with draining shields. Monitoring ports should be installed every 6 m (20'). These could be combined with vents if a vent line is installed.

Lateral ends to have cleanouts per pressure distributions system (linked standard).

Cover soil to be per standard for sand mounds (recommended in section 3.8) (linked standard), cover depth 150 mm (6"), not to exceed 200 mm (8") in any part of the trench system.

Commissioning should include balancing of system to ensure no greater than 10% variation in flow proximal to distal and from one lateral to another. Due to the small dose, this may best be achieved by measurement of discharge volume from test orifices at each lateral end.

Where the dispersal area is covered with loam or sandy loam soil to obtain needed cover depth, till (scarify) entire dispersal area prior to adding cover soil.

Where moisture monitoring is installed to monitor unsaturated conditions and vertical separation, install at a minimum one set of sensors at 150, 305 and 460 mm (6", 12" and 18") below the infiltrative surface. On a sloping site, upslope baseline sensor set will permit monitoring of rainfall impact.

Vehicles or heavy animal traffic should not be permitted on the finished system. This consideration could also apply to the receiving area for some sites.

#### 3.7.11.5 PSND MAINTENANCE AND MONITORING CONSIDERATIONS

Follow maintenance and monitoring considerations as per pressure systems (linked standard). Where used with moisture monitoring, the moisture readings should be collected by datalogger and the data should be reviewed at least once during the wet season and at the annual system review.

Testing of lateral flows should be per commissioning (above).

Use the monitoring ports to inspect conditions at the infiltrative surface.

#### 3.7.12 Subsurface Drip Dispersal (SDD)

SDD involves timed dose application of highly filtered effluent to small diameter drip tubing close to the ground surface; emitters in the tubing dose effluent at very low rates to the soil. Although these systems provide excellent dispersal and treatment, care in design and installation is critical.

SDD systems will result in the lowest site impact of all distribution systems, and thus could be used where the site or owner's requirements dictate very low impact. This low site impact is also important to the functioning of the system, and care in installation is critical to avoid impacting natural vegetation and soil structure (for example, by polishing and compacting soils with installation equipment). At times, hand installation may be preferable.

Design, installation and maintenance of SDD systems should to be carried out in accordance with standard practice to minimum standards as per:

Wastewater Subsurface Drip Distribution Peer Reviewed Guidelines for Design, Operation, and Maintenance

Final Report, March 2004 (Revised May 2004)

Tennessee Valley Authority, prepared by EPRI

This is available on the internet at [http://onsite.tennessee.edu/Drip\\_Guidelines.pdf](http://onsite.tennessee.edu/Drip_Guidelines.pdf)

SDD should only be designed/installed by APs educated in and competent in design/installation of SDD systems.

Timed dosing with low HAR (Hydraulic Application Rate) and full equalization is essential because:

- the technique relies upon maintenance of unsaturated conditions (for treatment) and upon provision of resting periods for reoxygenation (to prevent biomat build-up); and,
- saturation around the dripline should be avoided to prevent soil damage and to encourage the action of macro fauna.

The design should include the selection of appropriate Hydraulic Application Rate and instantaneous loading rate as well as HLR and LLR.

Note that HLR should be selected following the guideline listed in the box above in addition to Part 2 hydraulic loading rate (Table 2-8); this will lead to a reduction in HLR below that provided by Table 2-8.

Override or lag events should neither increase dose volume nor allow dosing in excess of the DDF.

### *Moisture Monitoring*

Where moisture monitoring is installed to monitor unsaturated conditions and vertical separation, install at a minimum one set of sensors per zone or at critical zones at 150 mm and 305 mm (6" and 12") below the infiltrative surface. On a sloping site, upslope baseline sensor set will permit monitoring of rainfall impact.

Where used with moisture monitoring, the moisture readings should be collected by datalogger and the data should be reviewed at least once during the wet season and at the

annual system review, with appropriate action being taken to correct any saturated conditions.

***Special Case Vertical Separation***

With the use of SDD in shallow soil situations, the dripline can be installed within the minimum standard natural soil vertical separation in certain cases, because treatment and dispersal potential of the natural soil and soil ecosystem is expected to be higher than if additional sand is added. Therefore, it is preferable to slightly reduce vertical separation than to add material.

This should ONLY be the case when the following conditions are met:

- where Type 3 or consistent Type 2 10/10 effluent is used,
- Hydraulic Loading Rates for Type 2 or 3 effluent are reduced by minimum 25% from the values provided by Table 2-8;
- where linear loading rates (Table 2-11) are not exceeded;
- where effluent is applied at low rates and by high frequency (low Hydraulic Application Rate) fully equalized timed dosing (over 24 doses/day at Daily Design Flows and over 12 doses/day at average flows);
- effluent is applied within natural soils with the dripline minimum 150 mm (6") and maximum 200 mm (8") below the ground surface (see Table 3-7);
- where soil moisture is monitored per the standards of Section 3.7.15; and,
- then Table 3-7 could be used.

**Table 3-7 SDD Special Case Reduced Vertical Separation**

Soil type and limiting layer	Effluent type	Minimum Vertical separation in native soil from dripline to limiting layer
Soils coarser than fine sand OR where over unconfined aquifer	Type 2 10/10	24" (610 mm)
	Type 3	18" (460 mm)
Other soils/conditions	Type 2 10/10	18" (460 mm)
	Type 3	12" (305 mm)

*NOTE:*  
 These application and moisture monitoring techniques can also suit application to coarse soils, soils overlying fractured rock/inceptisols or soils of very low hydraulic conductivity.

**3.7.13 Site Drainage**

**3.7.13.1 SITE DRAINAGE PERFORMANCE STANDARDS**

Interception drains (curtain drains) and relief drains should perform as designed, lowering the water table in the field area to needed depth consistently over the life of the system.

This should be assured through the use of water table monitoring standpipes.

Drainage systems should be designed and operated to avoid breakout of effluent containing pathogens which could cause a health hazard.

### 3.7.13.2 SITE DRAINAGE DESCRIPTION AND PRINCIPLES OF OPERATION

**Figure 3-26 Use of an Interception Drain**

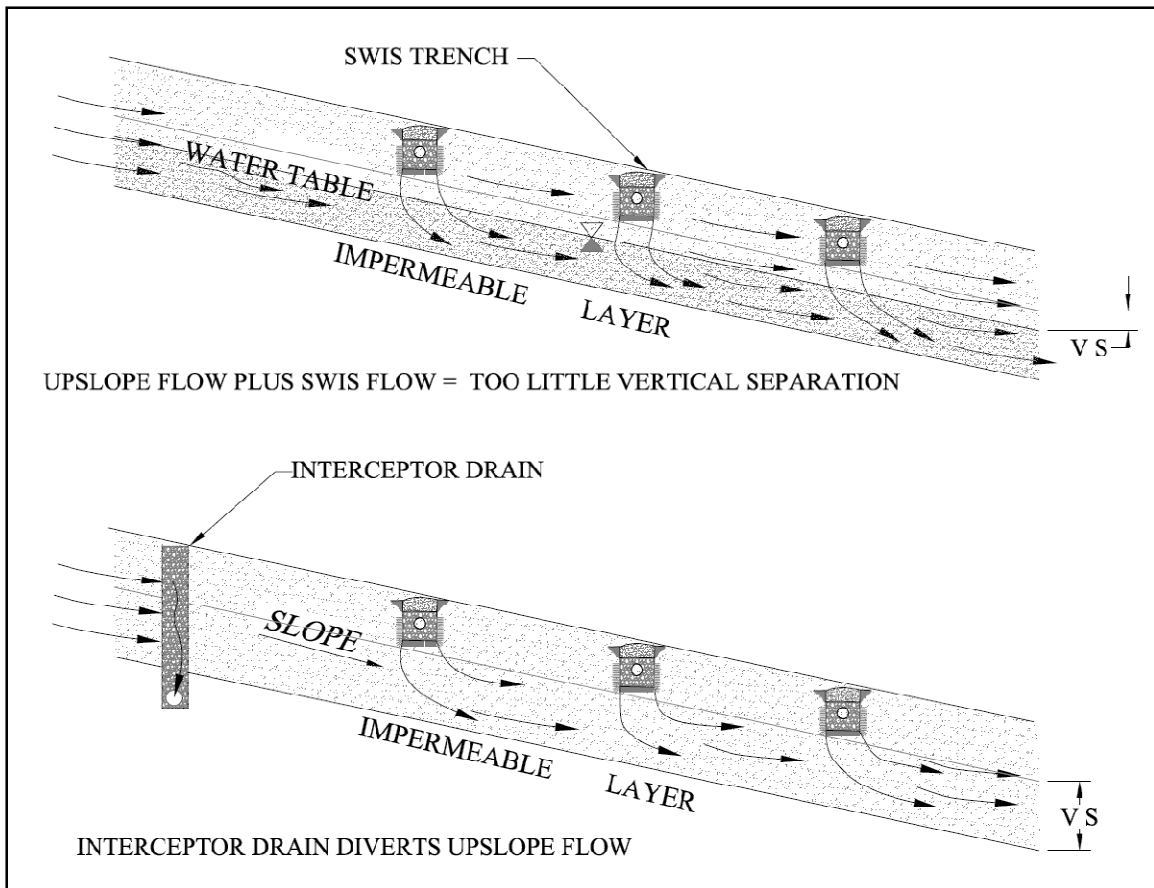

Interception drains act to divert water flowing on the surface and below the surface from upslope to the discharge area, improving vertical separation and in-soil treatment.

Toe and relief drains are used to lower the water table in the dispersal and receiving areas, and should be installed sufficiently far away to prevent breakout of untreated effluent. Relief drains could be used on flat as well as sloping sites to assist in addressing groundwater mounding, they are also known as “tile drains” or “field drains.”

An interception drain normally consists of a trench penetrating the restrictive layer by over 200 mm (8”), with drainage pipe and drain rock (or equal non aggregate system).

In most cases a downslope membrane is used to provide a subsurface dam and to reduce the probability of infiltration from the SWIS. This could be a lateral drainage material which also provides drainage paths.

The drain can have a surface swale to divert surface flows, with the water entering the drain system or being diverted separately.

### 3.7.13.3 SITE DRAINAGE DESIGN CONSIDERATIONS

Swales and drains should be designed to handle the peak flows expected from the upslope watershed or aquifer. In cases where large flows are expected specialized design of the swale and drain is strongly recommended and a hydrologist's opinion on expected flow volumes/peaks should be sought.

The drain should effectively intercept subsurface flow and be capable of carrying this flow away without causing flow concentration in parts of the discharge area or receiving area, thus the drain should, wherever possible, penetrate the restrictive layer to a sufficient depth that water flowing around the drain cannot escape downslope. The subsurface dam could also assist in ensuring water is successfully intercepted by the drain. Where the barrier layer is impenetrable the dam should be sealed to the layer.

Where large surface flows are expected, or where a swale is used alone, the base of the swale could be lined with an impermeable material (example Butyl Rubber) to prevent infiltration of the collected water.

If an interception drain (curtain drain) is to be installed in erodible soils, such as silty or fine sandy soils, then a filter could be necessary to reduce erosion of soil into the drainrock and drainpipe. Three basic types of filters are commonly used:

1. geotextile filter cloth;
2. one or more granular soils, typically fine gravel and coarse sand; and,
3. filter cloth combined with coarse sand.

The outfall of the drain should be considered in order to prevent erosion or other impact. Where the drain surfaces, the in-ground dispersal unit should be capable of dispersing the flow without causing adverse impact to slope stability or the SWIS, and should be provided with a monitoring water table monitoring standpipe.

Breakout of untreated effluent to drains should be prevented. The setback standards of Part 2 include upslope setbacks to interception drains and setbacks to downslope or relief drains.

*Note:*

This setback should be applied considering the path of effluent flow in the area below the discharge area. Where slopes are low and the drain is deep, the setback could need to be increased.

In addition, maintenance of unsaturated conditions below the dispersal area to ensure proper in-soil treatment will be more effective than large horizontal setbacks in saturated soils.

Drains should be designed using good field drainage practice.

It could be necessary to pre-install the drainage system and confirm its functioning by monitoring before installing the system.

#### 3.7.13.4 SITE DRAINAGE SPECIFICATIONS AND INSTALLATION CONSIDERATIONS

Installation should include care with drain slope and penetration of the barrier layer to prevent flow concentration. Where a membrane is used for a subsurface dam, this should be installed to prevent piercing or damage to the membrane.

Drains should be installed using good field drainage practice.

Where the drain transitions to solid pipe, care should be taken to avoid surcharged water continuing to flow down the trench. Using a Bentonite plug at that point in the trench could be a solution.

Where drains surface, they should be provided with an animal guard of corrosion resistant material. This should be removable for service.

Water table monitoring standpipes should be installed to the barrier layer and, where soils require, installed in sand or drain rock to ensure that they permit unimpeded passage of the water in the water table in and out of the pipe.

Install a minimum of two water table monitoring standpipes just above the discharge area and two 5 m (15') downslope. Note that short-circuiting of effluent may occur if the standpipes are installed in or very close to the dispersal trenches. This should be avoided.

#### 3.7.13.5 SITE DRAINAGE MAINTENANCE AND MONITORING CONSIDERATIONS

Water table monitoring standpipes should be monitored annually during the wet season. Where the water table is found to be rising over a period of years, or if drain flow stops, consult a qualified planner for remedial action.

During the wet season, the drainage system itself should be checked and maintained:

- monitor discharge point for adequate disposal, and check that discharge is not contributing to erosion or other downstream impact;
- vegetation in a swale or ditch should not restrict flows and the grade should be consistent and without points where pooling takes place. Slopes should not be too steep that erosion takes place;
- for an underground collection system, use a pipe camera sent up from the discharge end to check:
  - for restrictions due to rodent nests or soils being washed in,
  - if the pipe is uniform in shape and grade,
  - the point(s) where groundwater is being intercepted,

Note that the rate of collection is important as incoming flows that are very fast risk carrying silt/sand into the drain rock and any geotextile fabric where clogging can occur.

- if iron may be leaching into the pipe (which can lead to a serious form of clogging over time.) If this or other mineral accumulation is a problem, agricultural drain cleaning and jetting techniques could be used; and,

- the removable screen should be checked and repaired as needed.

### 3.7.14 SWIS on Sloping Sites

Sloping sites present a unique challenge for SWIS construction. Poorly constructed or installed systems on sloping sites will be more likely to malfunction.

#### 3.7.14.1 SLOPING SITES DESIGN CONSIDERATIONS

As slope increases spacing between trenches should be increased. Slopes greater than 15% need 3 m (10') horizontal separation between trenches.

On slopes over 15%, consider reducing trench width, (example to 460 or 305 mm — 18" or 12").

On slopes over 25%, consider pressurized shallow narrow trenches or Subsurface Drip Dispersal.

To determine depth of trench walls on a sloped site use Figure 3-27 as follows:

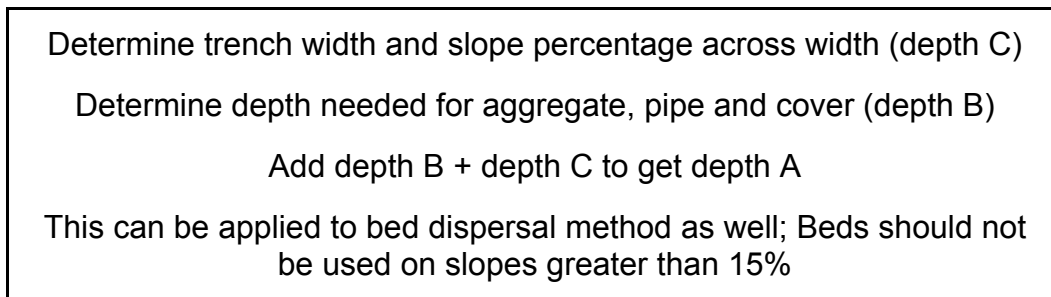

**Figure 3-27 Trench Depth Variance on Sloped Site**

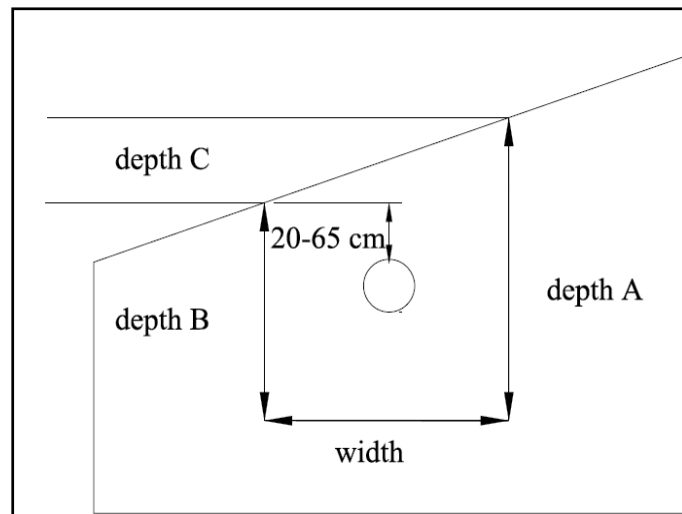

Protection of the downslope receiving area from impact could be particularly critical, and this could include the use of covenant areas.

### 3.7.14.2 SLOPING SITES SPECIFICATIONS AND INSTALLATION CONSIDERATIONS

Maintain proper unsaturated vertical separation and avoid excessive trench cover when constructing bed or trench type dispersal systems on sloping terrain.

When flows of water are concentrated, this encourages soil saturation and may also lead to washout of contaminants held in soils.

Consider what will happen if there is surface flow of water on the slope, and avoid having this concentrate into the dispersal trenches.

Consider the possibility of flow concentration in manifold and forcemain trenches where these lead downslope, and install dams (for example, Bentonite) in the trenches to prevent this. Also consider flow concentration in surface and subsurface features (example pathways or subsurface ledge rock).

On steeper slopes extra care should be taken to avoid soil structure degradation from machine traffic. Where slopes are over 25%, travel on the slope within the field area and receiving area should be avoided where possible. Vegetation should be re-established rapidly to reduce erosion, and the maintenance of as much natural cover as possible is important. Any vertical drainage paths should be avoided and water from interception drains or swales should be disposed of in such a way as to avoid erosion and to avoid surcharging the slope with water, which could adversely affect slope stability.

On very steep slopes, consider the risk of effluent flow concentration in cut off root channels surfacing downslope of the dispersal unit.

Upslope drainage and the impact of upslope development on potential runoff and concentrations of flow should be considered.

In some soil and slope conditions there is potential for slope stability to be an issue. Where necessary consult a geotechnical engineer.

## **3.8 *Media Filters with Integrated SWIS: (Including Sand Mounds and Sand-lined Trenches)***

---

### 3.8.1.1 SAND MOUNDS AND SAND-LINED TRENCHES PERFORMANCE STANDARDS

Performance standards and expectations of treatment in the filter media for these technologies are prescribed in Part 2, Section 2.3.4.2 and Section 2.3.4.3 and in Appendix G (linked standards).

Consideration should be given to design, installation and maintenance to ensure those minimum standards are met and that the filter media provide the expected treatment.

### 3.8.1.2 SAND MOUNDS AND SAND-LINED TRENCHES DESCRIPTION AND PRINCIPLES OF OPERATION

The mound is an above-grade soil absorption system used for wastewater treatment and dispersal. The mound system consists of a septic tank with effluent filter, a dosing chamber and the mound itself. The principal features of the mound are a gravel, aggregate or gravelless chamber layer (the “bed”) for distribution of the wastewater, a layer of mound sand media imported to the site, and a basal area consisting of the native, permeable, unsaturated soil. Effluent is distributed to the bed by pressure distribution, often using timed dosing. The mound is generally used to address insufficient vertical separation and/or very low permeability soils.

A sand-lined trench is similar technology, but enclosed in a trench or enclosure. It is generally used to address soils with unacceptably high permeability on sites with relatively deep soils. An above ground grade, sand-lined trench could be used where surface soils are of very high permeability or very low permeability.

Sand-lined trenches can also be used where surface soils are of low permeability and there are unsaturated soils at depth that offer better possibilities for dispersal. In this case the sand-lined trench is designed to penetrate the low permeability soils and reach the desirable layer. However, the infiltrative surface is still kept near the ground surface to permit oxygen diffusion.

Treatment in the sand is used to reduce BOD/TSS levels and pathogen levels at the basal area. For this to be successful, the effluent should disperse through the sand by unsaturated flow, and the effluent should be well distributed to the surface of the sand.

For this reason all systems of this type should use pressure distribution and it is preferable to use timed dosing (linked standard).

**Figure 3-28 Example of a Mound Cross Section Showing Nomenclature**

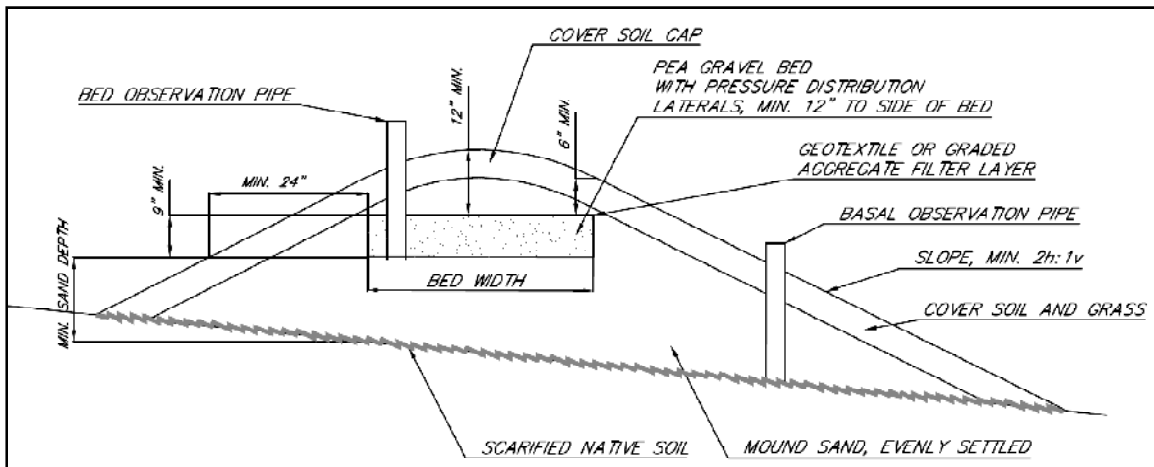

**Figure 3-29 Sand-lined Trench**

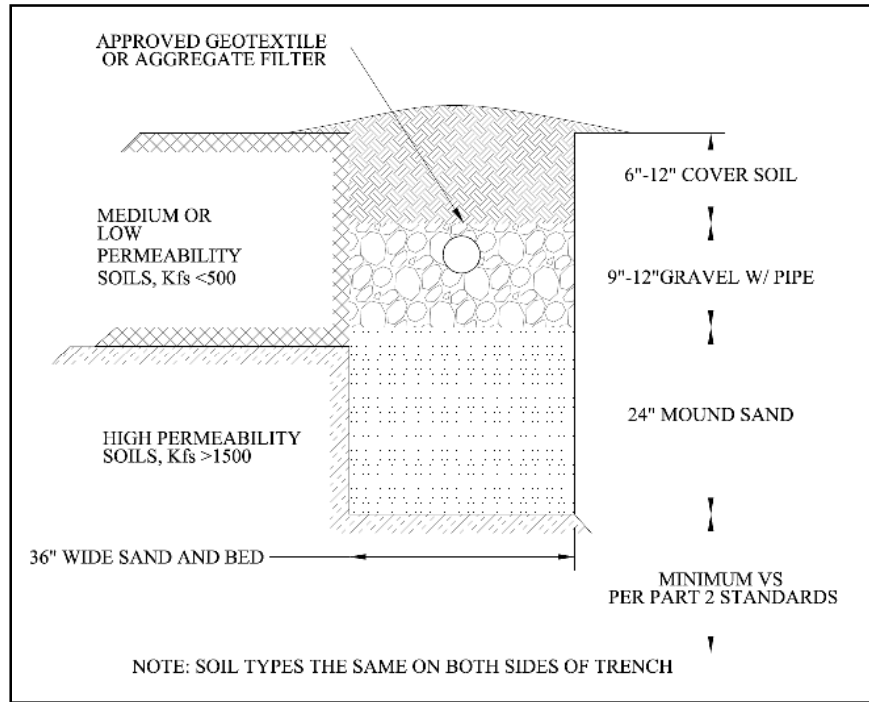

**Figure 3-30 Sand-lined Trench with High Permeability Soils to Surface, Option 1**

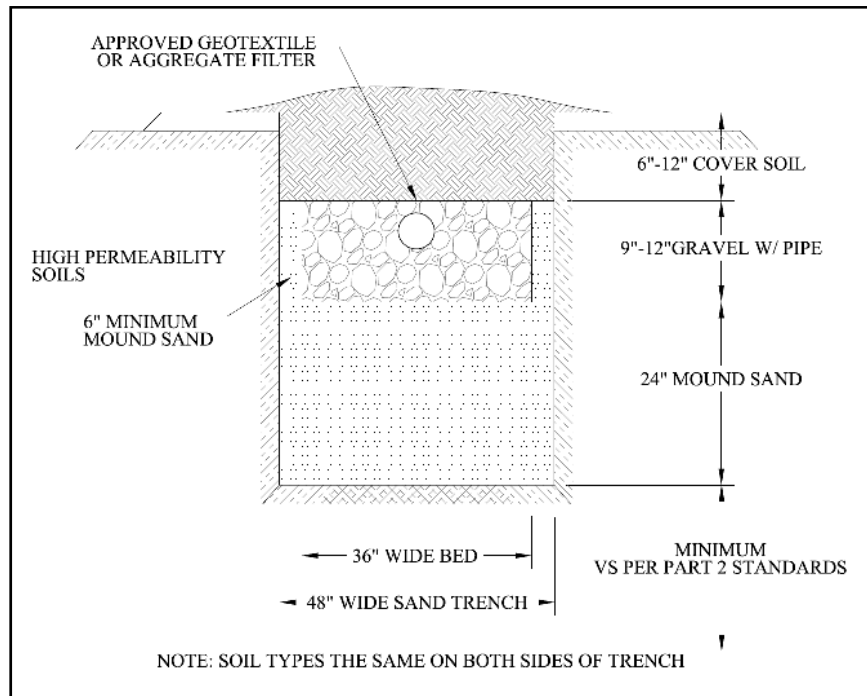

**Figure 3-31 Sand-lined Trench with High Permeability Soils to Surface, Option 2**

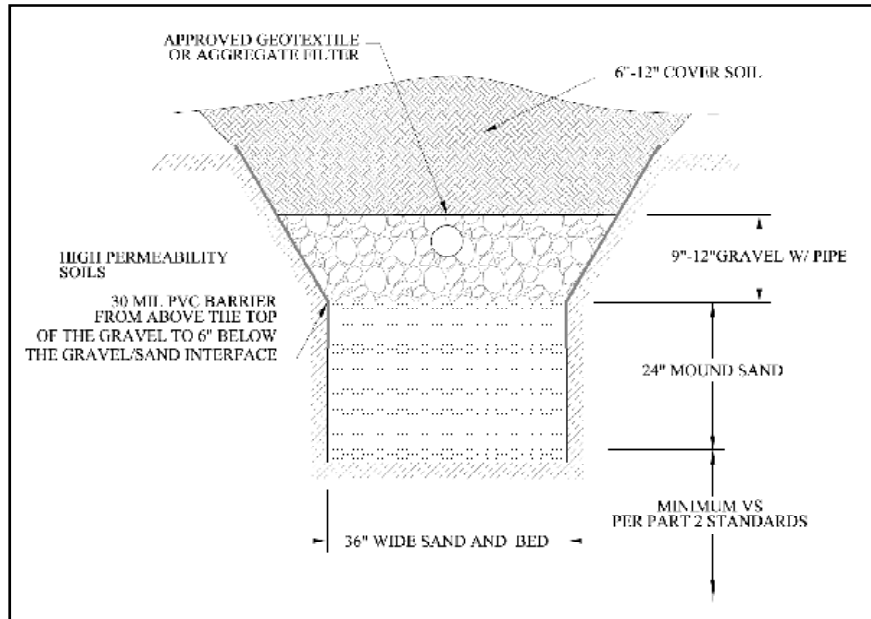

**Figure 3-32 Sand-lined Trench to Reach Suitable Soil at Depth**

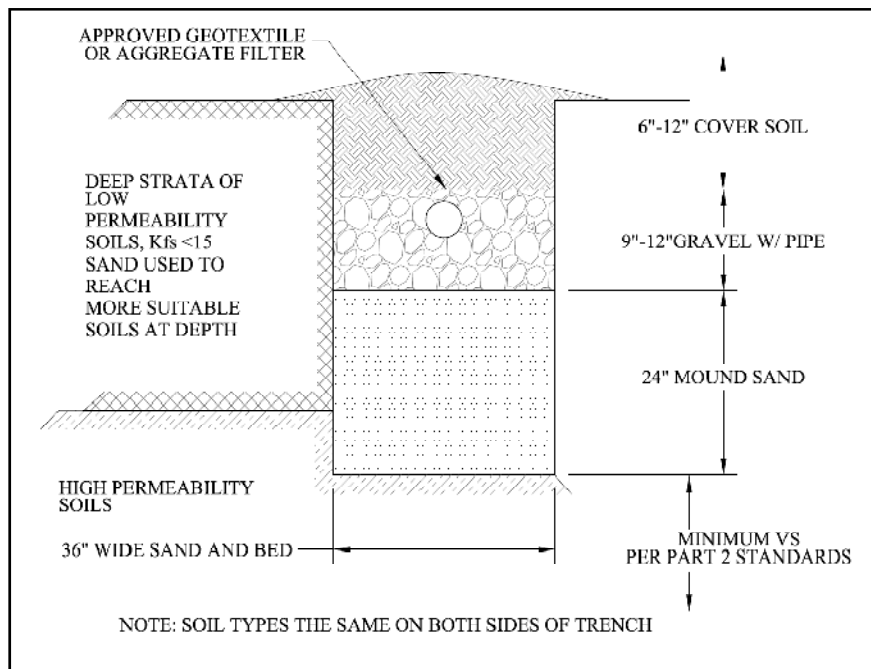

**Figure 3-33 Above Ground Sand-lined Trench**

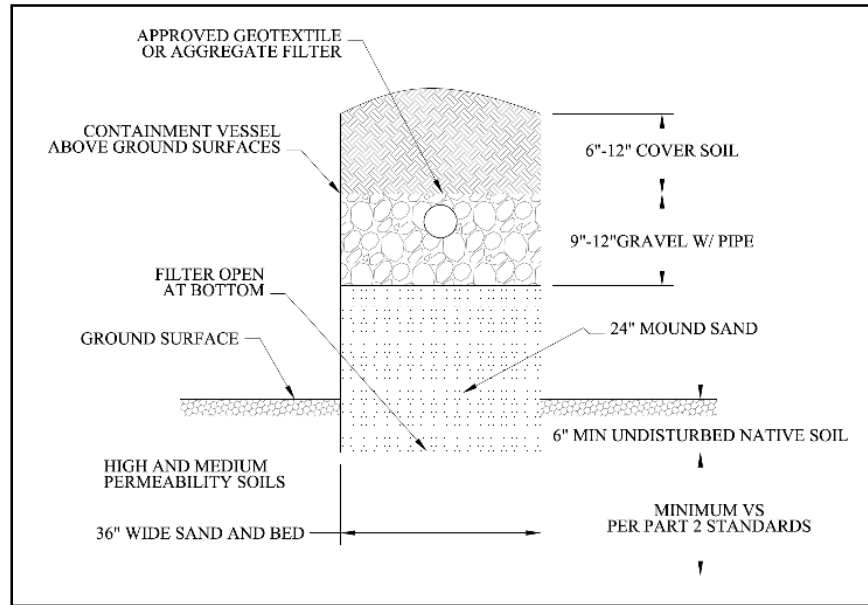

### 3.8.1.3 SAND MOUNDS AND SAND-LINED TRENCHES DESIGN CONSIDERATIONS

#### *General*

The design of the system depends on wastewater characteristics, siting standards, loading rates and sizing.

Selection and application of an applicable LLR should form part of design for this technology. For deep, highly permeable soils, LLR will be the maximum LLR for oxygen flux considerations; see Part 2 (linked standards).

Effluent should meet Type 1 standards at minimum and should also meet reduced O&G levels (see Part 2 Section 2.4) (linked standard).

Sites should be critically evaluated for their suitability for a mound or sand-lined trench system. Beyond loading rates and vertical separation, it is essential to consider water flow paths away from the mound, areas of potential flow concentration, surface water flows, integration to the landscape and to consider the potential impact of rainfall.

#### STEPS OF DESIGN PROCESS — SAND MOUNDS

The design of the physical layout of a mound system is described in Appendix H, and a worksheet for mound design is provided.

Refer to Wisconsin Mound Soil Absorption System: Siting, design and construction manual by James C. Converse and E. Jerry Tyler, 2000 for further details and background reading.

**Figure 3-34 Mound Layout Schematic, Letter Dimensions Are as Used in the Worksheet.**

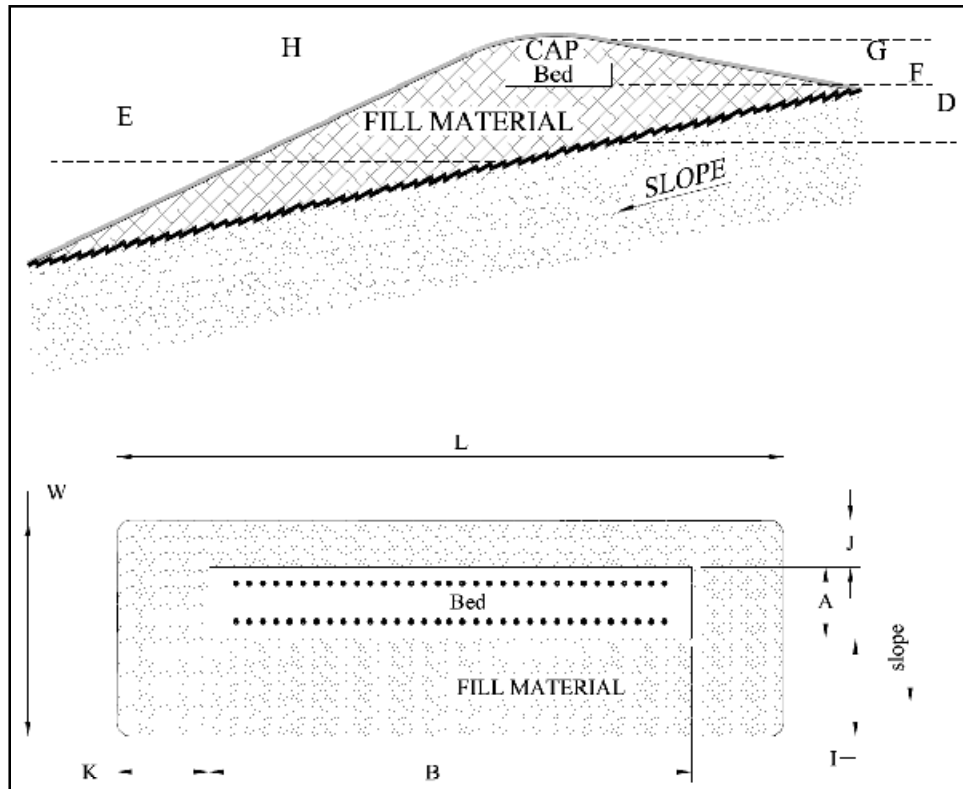

These systems should be constructed perpendicular to the slope, following contour, and should be long and narrow addressing LLR standards. LLR should be considered for the area directly under the systems and the receiving area (7.5 m (25') downslope on a sloping site, 7.5 m (25') to all sides on a site with slope under 1%).

Minimum Vertical Separation and sand media depth standards are supplied in Part 2 (Section 2.3.3), where sand-lined trenches are used, and the minimum native soil vertical separation should exist under the base of the trench.

Where mounds are installed over filled areas, a qualified Professional should make recommendations for basal area loading and required soil remediation.

Pressure distribution should be used. Design pressure system as per Section 3.7.7 (linked standard).

Mounds are not normally used on slopes above 25% due to construction constraints.

Large trees and boulders can inhibit site preparation and soil absorption and therefore are generally avoided. However, if there are no other desirable locations to site a mound, trees can be cut to ground level and stumps and boulders left in place. On sites where tree stumps or boulders occupy a significant area, the mound's basal area should be increased. Where the trees may re-grow from the stumps, the stumps should be killed by using copper or other method.

Where gravelless chambers are used, a maximum area of 0.37 m<sup>2</sup> (4 ft<sup>2</sup>) per orifice should be used.

Provide detailed design notes, specifications and distribution system layout plans.

**Figure 3-35 Horizontal Setbacks are Measured from the Edge of the Minimum Basal Area of the Mound**

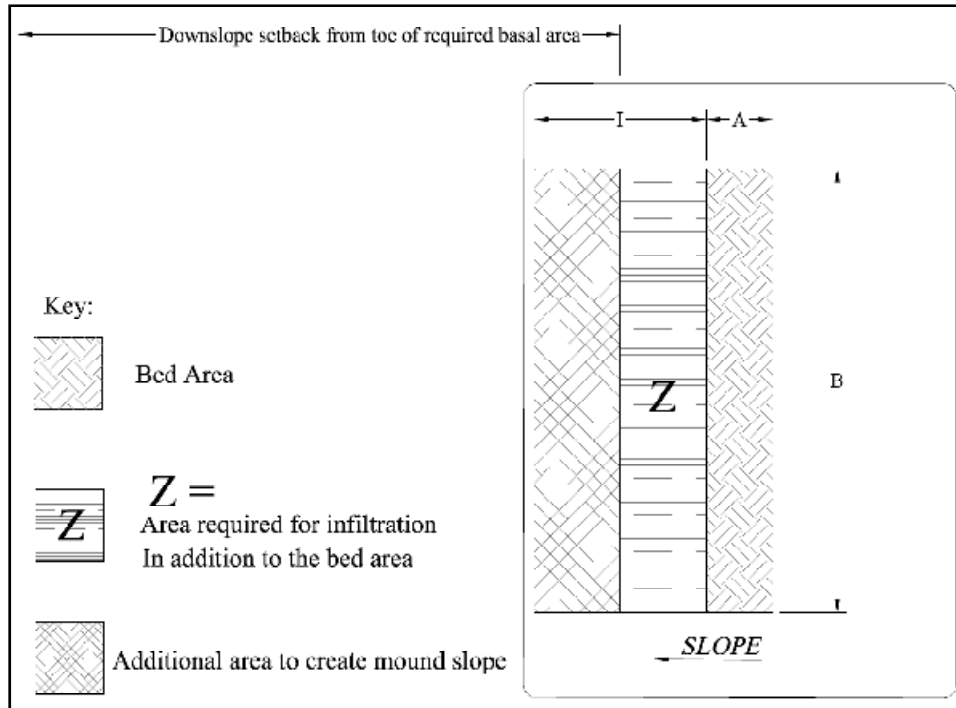

- Determine the distribution bed size needed using linear and hydraulic loading rates from Part 2.
  - the distribution bed length (or system length for sand-lined trenches) is determined by use of the LLR, the sand media loading rate is then used to determine minimum bed width. See below for concave bed length adjustment;
  - a mound can be designed using trenches or beds. Trench or bed can use aggregate, synthetic aggregate or chamber process; and,
  - the distribution bed basal area should be level along length and width. Where the site requires the distribution area could be stepped down across the slope.
- The mound is designed around this distribution surface. Basal area is then checked to ensure the Basal HLR is not exceeded. See worksheet in Appendix H. Key constraints when designing the layout of the mound include:
  - bed width not to exceed 3 m (10')
  - minimum pea gravel depth under distribution network 100 mm (6"), minimum over pipe 25 mm (1"), where ¾" drainrock is used increase depth below pipe to 230 mm (9") and over pipe to 50 mm (2").
  - minimum cover of bed 150 mm (6"), maximum 460 mm (18") in centre (305 mm (12") preferred)

- mound cover to be sloped to encourage rain runoff. Minimum cover slope from centre to bed edge 6" (150 mm).
- maximum side slope 2h:1v
- sand minimum depth is measured below the upslope edge of the bed.
- minimum separation from bed edges/ends to exposure is 610 mm (24")
- on flat sites the effective basal area is considered to be the area under the bed and on all sides. On sloping sites this is considered to be the area under the bed and downslope of the bed;
- where basal area available is reduced due to rock fragments, boulders, stumps, etc. the amount of reduction and the adjustment to basal area and/or mound size should be technically justified and sufficient to make up for the soil infiltration area lost to the tree trunks, stumps, and boulders; and,
- Setbacks from mounds are calculated from the edge of the minimum basal area. See Figure 3-35.

#### DOSING AND DISTRIBUTION

##### Dosing and distribution:

- use pressure systems per Section 3.7 for all sand mound/sand-lined trench distribution systems:
  - ensure a minimum of one orifice per  $0.56 \text{ m}^2$  ( $6 \text{ ft}^2$ ).  $0.37 \text{ m}^2$  ( $4 \text{ ft}^2$ ) is needed with chambers and is preferred for aggregate systems.
  - minimum 305 mm (12") separation from orifices to outside of bed,
  - stagger orifices in neighbouring laterals;
- preferably, use timed dosing for these systems. For Type 1 systems with timed dosing:
  - the maximum dose per square metre should not exceed 10% of the moisture holding capacity of the mound sand directly below the bed. Moisture holding capacity of mound sand can be taken to be 50 mm/m (5% vv),
  - for a 610 mm (24") sand depth this equates to approximately  $3 \text{ L/m}^2$  per dose,
  - to achieve this, dose at a minimum of  $14 \times$  per day at DDF for 610 mm (24") sand depth,  $18 \times$  per day at DDF for 460 mm (18") sand depth or where sand depth is less than 460 mm (18") at a minimum of  $24 \times$  per day at DDF;
- where demand dosing is used for Type 1 systems, maximize the number of doses per day, dose at a minimum of  $8 \times$  per day at DDF;
- where Type 2 or Type 3 effluent is used in design of a sand mound, timed dosing should be used. The maximum dose per square metre (HAR) should not exceed 10% of the moisture holding capacity of the mound sand directly below the bed. Moisture holding capacity of mound sand can be taken to be 50 mm/m (5% vv)
  - for a 610 mm (24") sand depth this equates to approximately  $3 \text{ L/m}^2$  per dose,
  - the high loading rates permitted in Part 2 will need a large number of doses per day. For example, with 610 mm (24") of sand and Type 2 loading of 64

L/day/m<sup>2</sup>, this results in a minimum 21 doses per day at DDF. This could require the distribution network to be kept full of effluent between doses, which can limit the use of this loading rate in climates where laterals need to drain to prevent freezing; and,

- where Type 2 or 3 effluent is applied at Type 1 loading rates, there is a concern that biomat may not be effectively contributing to distribution and treatment. Timed dosing should still be used, but in this case minimum doses per day will be reduced to Type 1 levels.

*Note:*  
For discussion of hydraulic application rates see Appendix Q.

#### STEPS OF DESIGN PROCESS — SAND-LINED TRENCHES

Design of a Sand-lined Trench system is similar to a sand mound, particular considerations are:

- the system length is determined by use of the LLR; the sand media loading rate is then used to determine minimum bed width. In the case of trenches this could be spread over more than one trench, keeping each trench bed to 910 mm (36") basal width or less. See Figure 3-29 to Figure 3-33. See Figure 3-36 for concave bed length adjustment.
- the trench basal area is checked against the basal HLR, and the system is arranged to ensure the system LLR does not exceed design.
- ensure that provisions are made to prevent effluent from short circuiting to the trench sides, where highly permeable soils extend up to the bed level, (see Figure 3-30 Figure 3-31 for two strategies).
- for above ground sand-lined trenches, the containment vessel should be watertight and should be of a material that will continue to provide support over the system life:
  - a common technique is the use of pressure treated landscape ties (secured at the corners) forming a box. The box is lined with a 45 mil. Butyl rubber (EPDM) liner which is protected by a layer of non woven geotextile placed between it and the supporting landscape ties. The landscape ties should not extend below the ground surface as they will rot and cause voids. They should be built upon a firm base of crush or drainrock; and,
  - the enclosing membrane should extend below ground 150 mm (6") minimum (see Figure 3-30).
- effluent distribution (including bed criteria), dosing and HAR considerations are as per sand mounds.
- the cover of an above ground sand-lined trench should encourage diversion of rainwater (except where the trench is designed to accept the rainwater and is covered with drainrock).

CONTOUR CONSTRUCTION AND SPECIAL INSTRUCTIONS FOR SYSTEMS ON CONCAVE SLOPES

The system is placed along the contour, and where the contour is curved to give a concave (from side to side) slope, the effective bed (cell) length is given by the distance between the furthest points along the contour line of the downslope edge of the concave distribution cell. Where the deflection from a straight line exceeds 10% the slope is not suitable for mound construction at standard loading rates.

However, if subsurface water flow is primarily vertical and/or vertical separation is over 1.83 m (72"), it is not necessary to apply this consideration.

**Figure 3-36 Calculation of Effective Bed Length on Site with Concave Contour**

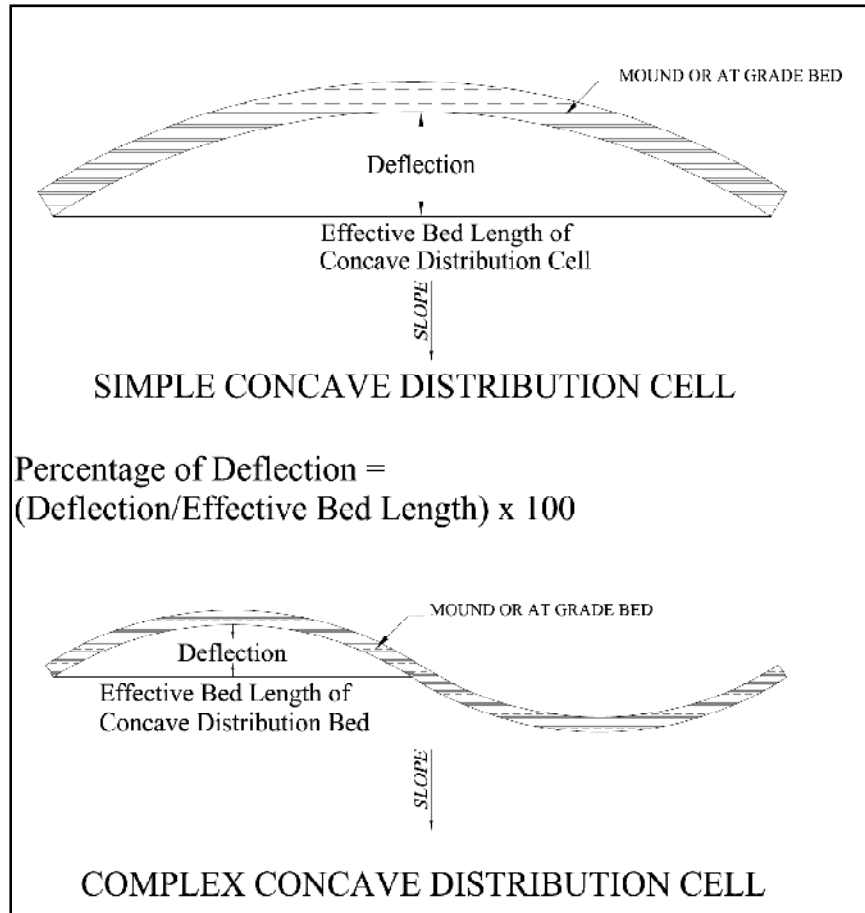

Example: If effective (“bowstring”) length is 30 m and deflection is 1.5 m, the percentage of deflection =  $(1.5 \div 30) \times 100 = 5\%$

### 3.8.1.4 SAND MOUNDS AND SAND-LINED TRENCHES SPECIFICATIONS AND INSTALLATION CONSIDERATIONS

#### *General*

See Appendix H for checklist of installation steps (provided as part of the sand mound worksheet).

Site preparation is critical for sand mound installation.

Ensure that the forcemain trench does not serve as a flow channel.

Aggregate and sand should be kept clean.

Pressure effluent distribution system is as per Section 3.7.7, with a minimum of 305 mm (12") from lateral piping to edge of bed.

Perform a comprehensive test of all components and distribution pressure test to verify that the distribution system is in proper working order prior to final backfilling, grading and placing into operation.

The bed could be covered with geotextile (per trench section) or, preferably, a bird's eye/sand graded aggregate filter could be used to prevent topsoil from contaminating the bed.

Finished distribution area should be graded so that rain or ground water can drain away from the site.

Seed or sod the site immediately after construction to prevent erosion. Avoid trees, shrubs, bamboo etc.

Vehicles or heavy animal traffic should not be permitted on the finished system. This consideration could also apply to the receiving area for some sites.

#### *Preparation of Basal Area*

All work should be done when: soil moisture conditions will not adversely affect soil structure and hydraulic conductivity, the site is dry, and compaction from machinery will not cause significant damage to the distribution area.

The system should be constructed in a manner that does not damage the native soil structure by smearing or compacting of soil surface or compacting soils below the basal area. Soil moisture at depth should be considered even when the surface is dry.

Check soil moisture at surface and at 200 mm (8") depth, ensure that the soil will crumble in the hand and will not roll to form a wire (i.e., is not plastic).

Where possible, work only from sides and top of mound area and avoid travel on receiving area or mound area. Where machines must travel on mound area ensure tracked vehicles with maximum 7 psi ground pressure are used and minimum 150 mm (6") of sand is kept under the tracks.

Sand-lined trenches' and bottomless sand filters' basal area should be lightly scarified.

Sand mound basal area vegetation should be cut by hand to ground surface and removed/raked off. Very deep sod should be ripped and sand should be incorporated. Excess grass, sod or duff may form a low permeability layer below the sand and should be removed.

For a sand mound basal area soil should be prepared by scarifying the surface along the contour to a depth of not less than 150 mm (6"). The purpose is to roughen the surface and provide for better infiltration from the sand to soil. This will also reduce flow concentration in macropores and the potential for saturated flow. Excessive disturbance that destroys soil structure should be avoided. Rototillers should not to be used. Chisel ploughs or similar are acceptable.

Where deeper ripping is used to break up platy "plough pan" layers, this should not disturb surface soil structure beyond the ripper shank paths. Check that the layer has actually been broken successfully.

Tillage around stumps should avoid pulling out excessive amounts of roots. Any small stumps pulled out should be removed. Where there are many stumps or boulders, hand scarification is strongly recommended around them. A spade or heavy hoe/mattock could be used.

Sand fill placement should begin shortly after basal area is prepared.

### *Aggregate*

Use pea gravel (3–12 mm, 1/8 – 1/2" stone), washed and with <1% by weight passing the #200 sieve with a minimum hardness of 3 on the Moh's scale.

Where drain rock is used, this should be a maximum of 25 mm (1") ("3/4" drain rock"). See Trench Section 3.7.3 for drain rock aggregate specification (linked standard).

### *Mound Sand*

Fill material should conform to Mound Sand standards and should meet the standards of the following Table 3-8 Mound Sand Particle Sizing .

Alternate sand specifications are provided in the Appendix H, where none of the provided specifications can be met, the sand loading rate should be established by a Professional. See Appendix H for further information (linked standard).

**Table 3-8 Mound Sand Particle Sizing Criteria**

Sieve	Effective Particle Size	% Passing
No. 4	4.75 mm	95 – 100%
No. 8	2.36 mm	80 – 100%
No. 16	1.18 mm	50 – 85%
No. 30	0.6 mm	25 – 60%
No. 50	0.3 mm	10 – 30%
No. 100	0.15 mm	<4%
No. 200	0.075 mm	<1%

***Cover Soil***

Cover soil:

- provides frost protection;
- prevents erosion;
- prevents excess precipitation or runoff infiltration; and,
- and should allow air to enter the distribution cell.

Sand soils are not suitable. A sandy loam is recommended.

Installation of cover soil should avoid excessive compaction of the soil, and rapid establishment of grass cover is important.

***Geotextile or Filter***

The cover soil should be prevented from infiltrating into the aggregate bed.

Use a graded filter (for example, a mound sand over pea gravel or birds eye gravel), or use a geotextile.

Where used, the geotextile should meet standards of trench section or be designed based on soil particle size analysis (linked standard).

***Uniform Density for Sand Media***

Sand fill should be settled to uniform density.

Uniform density could be accomplished one of two ways, depending on the moisture content of the filter media during construction.

If the filter media is so dry that it can be poured (like salt or sand in an hourglass), it can simply be poured, then settled lightly (not compacted) to allow about 5% volume reduction.

If the filter media is moist enough that it cannot be poured, it should be placed in successive 150 – 200 mm (6 – 8") lifts with each lift lightly settled.

Excessive wetting of the sand during settling should be avoided as this may encourage particle sorting/stratification.

Avoid stretching or damaging the liner when walking the sand into the edges of an above ground sand-lined trench. Careful packing at the edges will reduce short-circuiting of effluent.

Use clean shoes inside the sand mound/trench to prevent contaminating the sand. Keep equipment tracks clean for the same reason.

A penetrometer could be used to confirm even density through the depth of sand.

*Note:*

The intent of the light settling is to eliminate large voids in the media that may collapse or settle later when effluent is added. The light settling could be accomplished by walking on the sand, then raking (with hand tools) into the corners and along the sides (for trenches) and around monitoring ports. The final sand bulk density should be approximately 1.3 to 1.4 g/cm<sup>3</sup> (81.2 to 87.4 lb/ft<sup>3</sup>). Higher densities will reduce infiltration rates and oxygen exchange potential. (Ref. Washington State RS&G, Sand mounds)

### *Observation Ports*

Provide for an effluent infiltrative surface observation port and basal area observation port. These are installed in a similar fashion to those used in trench systems, except that the combined cleanout and observation port may not work well. The bottom 100 mm (4") of the observation pipe should be slotted, and include a provision to resist uplift. Use two pairs of observation ports; locate approximately  $\frac{1}{6}$  of the bed or trench length from each end along the centre of the mound, trench or filter's width.

In the case of sand mounds the basal area monitoring observation port should be installed approximately half the toe distance from the bed edge. For sand-lined trenches care should be taken to avoid effluent short-circuiting down the sides of the observation port pipe, and the pipe should be installed minimum 305 mm (12") from the nearest orifice. A plastic flange dam at bed level could also assist, as will careful compaction of the sand around the pipe.

### *Considerations Particular to Above Ground Sand-lined Trenches*

Edge of above ground trench unit should be minimum 150 mm (6") above grade, and the surface should drain away from the filter for minimum 1.5 m (5') around filter. The curb of the filter should discourage vehicle access (which should not be permitted onto the filter).

The liner should extend a minimum of 150 mm (6") into native soil.

Maintain a minimum of 3 m (10') separation to nearest tree or shrub, or use a root barrier fabric.

Where liner walls are below grade, the liner could be temporarily supported as per sand filter standard practice by a sacrificial wooden frame. Backfill inside and out at same time to prevent distortion. Any nails in the frame should be hot dip galvanized and

installed with heads facing the filter. Where above grade, the liner should be supported by durable materials — landscape ties locked at corners with galvanized rod, concrete lock blocks etc., and these may need to be supported by a foundation of crushed rock or similar.

When installing liner ensure that geotextile evenly protects the liner. Do not allow liner to be stressed or stretched. If needed, leave folds or loose areas in the liner. Installation is considerably easier with a pre-cut liner.

Pipe penetrations of the liner should be avoided where possible, and if essential, should be watertight sealed using a boot welded to the liner.

### 3.8.1.5 SAND MOUND AND SAND-LINED TRENCHES MAINTENANCE AND MONITORING CONSIDERATIONS

Follow relevant provisions of pressure system/trench systems (linked standard). Particular care should be given to ensuring mound and receiving area are not impacted by traffic, site use, etc.

Monitor the effluent infiltration surface observation ports and basal area observation ports. Check the infiltration surface observation ports prior to a dose and the basal after a dose:

- where bed interface to native soil is ponding, the cause should be determined and rectified. This could include excess biomat accumulation due to poor oxygen infiltration through over compact cover soils, original poor basal area preparation or hydraulic overloading.
- severe clogging or hydraulic overloading at the mound and natural soil interface will cause surface seepage at the base of the mound. This may be due to improper installation or other factors. This area should be permitted to dry, the downslope area re-prepared and additional filter media added. If this does not correct the problem, the system may need to be replaced; and,
- a good water conservation plan and plumbing repairs within the house or establishment will help assure that the mound system will not be hydraulically overloaded.

## **3.9 *Evapotranspiration/Absorption (ETA) and Evapotranspiration (ET) Beds***

---

### 3.9.1.1 ETA AND ET BEDS PERFORMANCE STANDARDS

ETA or ET beds should be of suitable size and design to ensure that all effluent is dispersed or evaporated/transpired over the year, with no surface discharge of effluent.

To reduce the possibility of contributing to the creation of a health hazard, they should disperse or evaporate effluent without any surface discharge to ground (example at the

bed edges) or water body and should not pollute groundwater. They should also be located and operated in such a way as to reduce opportunity of disease transmission by vector access (example flies, animals).

### 3.9.1.2 ETA AND ET BEDS DESCRIPTION AND PRINCIPLES OF OPERATION

Evapotranspiration/absorption (ETA) beds are used in areas with high positive Evapotranspiration balance in order to address low permeability soils.

They can be used with a liner as purely Evapotranspiration (ET) beds (with no absorption to soil) in other soils. Pure ET beds are normally only used in areas with net positive evaporation (evaporation in excess of rainfall) of at least 610 mm (24").

Evapotranspiration of water from a well designed bed should exceed lake evaporation or pan evaporation and should continue throughout the year (even in cold weather or with uncompacted shallow snow cover); however, it will be lower at some times of the year than at other times.

The beds are of various types, but common features are:

- shallow depth in native soil (305 – 380 mm (12 – 15")), with part of the bed installed above the ground surface to divert storm water (swales could be needed). Overall bed depth at edges approximately 460 mm (18")'
- long and narrow profile'
- on sloped sites, dosed serial trench systems could be used in place of the bed;
- level soil interface with a tolerance of 12 mm (½");
- soil interface is scarified;
- sand layer at base (C33 sand or mound sand) to reduce flow concentration to macropores and prevent sorting of fines at soil interface, and to prevent flow concentration due to gravel (where gravel used);
- aggregate (per trench or seepage bed systems, maximum 25 mm (1") aggregate — “¾" drain rock”) or gravelless system for distribution below lateral pipes. Lateral pipes are installed at the top of the aggregate layer in order to encourage wetting of the capillary layer,
  - in some designs, the laterals are surrounded by chambers or aggregate and the capillary layer is installed between them as well as above. This encourages capillary rise and is thus preferable,
  - gravity laterals could be side slotted rather than perforated in order to improve distribution;
- vented distribution pipes (gravity systems) or vent pipes (pressure systems), there could also be secondary 50 mm (2") vent pipes above and below distribution pipes, and in some cases these are supplied with pressurized air;

- sub drain pipes at the base of the aggregate layer to permit cleaning/flushing of bed aggregate. These are normally brought to surface for vacuum pump connection, and could also serve for venting;
- observation ports (per trench or seepage bed systems), installed  $\frac{1}{5}$  of bed length from ends to base of bed, minimum four pipes per bed;
- sand or loamy sand layer above aggregate, normally 180 to 230 mm (7" to 9") deep, to provide capillary rise of water to surface and to permit oxygen transport. The cover soil is crowned to 2% or greater slope to divert storm water,
  - this layer is separated from the aggregate layer by a graded aggregate filter (example a pea gravel layer),
  - selection of sand is made to ensure that its capillary rise is greater than the bed depth (example 18" (460 mm)), but not so fine a sand that oxygenation will be poor and lead to biomat plugging the media;
- the capillary layer could be covered by up to 2" (50 mm) of loamy sand cover soil (topsoil) OR sod as per sand mound use (shallow topsoil is important for improved evaporation);
- surface planted with sod (turf) plus low evergreen bushes of a type that have root depth of 12" – 18" (305 – 460 mm) (but not of a type that will be invasive);
- surface protected from access/compaction, snow cover not to be compacted;
- where Type 1 effluent is used the bed is dosed, to encourage reoxygenation between doses;
- pre-treatment facilities optimized to reduce TSS;
- where no absorption component is included because a liner is used, the bed could be designed to pond internally to be anaerobic for much of its depth during large parts of the year. A sectional bed (similar to celled lagoons) could be used to encourage ponding during dry weather to improve capillary rise and so Evapotranspiration; and,
- the bed could be used seasonally.

### 3.9.1.3 ETA AND ET BEDS DESIGN AND SPECIFICATION/INSTALLATION CONSIDERATIONS

ETA/ET beds should only be designed and installed by APs educated in and competent in design and installation of these systems, and they should only be used in areas of the province where Evapotranspiration data supports their use.

To meet the performance standards, the beds should be designed, installed and operated so that effluent that infiltrates has sufficient travel time in the soil to prevent pathogens reaching a water table or other compliance boundary. People or vectors such as flies and animals should not come into contact with effluent at the ground surface. Effluent ponding on the surface is not permitted.

**Critical Site/Soil Standards:**

- Where design indicates that the bed will pond to a depth greater than 150 mm (6") during parts of the year for more than 21 consecutive days, the bed should be constructed in soils with a soil percolation rate equal to or slower than 60 minutes/2.5 cm (1") or Kfs less than 20 mm/day, or it should be designed as an ET bed and be lined with a minimum 45 mil butyl rubber or equivalent liner. In other cases, the bed should be designed following the soil type and soil HLR standards for seepage beds or should be designed or the design reviewed by a Professional.
- ETA beds should not to be used where there is no net positive Evapotranspiration on an annual basis, except where designed or the design reviewed by a Professional.
- ET beds should not to be used where the net positive Evapotranspiration is less than 610 mm (24"), except where designed or the design reviewed by a Professional.
- In all cases, a reserve bed area should be set aside, of equal size to the constructed area. If flows are primarily horizontal, this area should be located so that it does not contribute to the same linear loading path as the primary bed.
- Site investigation should include characterization of the soils to at a minimum 1.2 m (4') below the bed excavation depth (and low permeability soils or solid rock should extend to that depth, with no sand lenses); test pits should not be located directly in the bed area. Minimum vertical separation is as per Part 2 standards and minimum horizontal setbacks are as per Part 2 gravity distribution standards.

Design loading rates are selected based upon soil HLR plus expected Evapotranspiration contribution. As the latter will be low during parts of the year, a conservative loading rate should be used if anaerobic conditions in the bed are to be avoided (due to extended ponding).

Research by Bernhart (1973) and Winneberger (1972) indicate an average design rate of 4.9 L/day/m <sup>2</sup> for Evapotranspiration in northern climates, EPA (2000) recommend 1 – 3 L/day/m <sup>2</sup> for pure ET beds.
---

The AP should select a suitable rate for the area in which the bed is to be constructed, and the basis for this selection should be included in the design documentation. If ponding is needed in the bed, design documentation should include calculations demonstrating that effluent will not surface or discharge to surface at any time of year.

Research indicates that, for water budget calculations, water gained from rainfall for a well designed bed is expected be less than 25% of total rainfall. Wider beds or those with poor vegetation coverage, poor camber, inappropriate surface soils etc. could gain more than 25%.

Width of the bed is determined by considerations of adequate aeration and surface drainage.

Salt accumulation could require bed flushing if it affects vegetation growth.

The restriction on maximum size of gravity distribution systems (Section 3.7.4.2) does not apply to ETA and ET beds; however, it is recommended that dosing be used to improve distribution where bed basal area exceeds 1,000 ft<sup>2</sup> and that laterals be center fed when over 50' in length.

Design documentation should include all calculations and references used to arrive at bed size, such as:

- total rainfall and snowfall based on a reliable source with long-term records (example Environment Canada);
- the percentage of the rainfall and snowfall that will infiltrate into the soil and the percentage that can be expected to runoff the system;
- the annual land evaporation rate of the area and the expected annual Evapotranspiration, based on a reliable source;
- calculated net Evapotranspiration (rainfall/snowfall into the system minus Evapotranspiration out) for each month and for the year;
- the permeability of the underlying soil;
- a design loading rate;
- the vertical rise of water than can be expected in the cover soil/sand due to capillary action; and,
- a water budget demonstrating that the bed will not saturate to grade.

#### 3.9.1.4 ETA AND ET BEDS MAINTENANCE AND MONITORING CONSIDERATIONS

Follow the relevant provisions of the seepage bed, gravity and pressure distribution systems sections (linked standard).

Vegetation should be maintained to provide good surface evaporation from the bed as well as transpiration from the plants. Evapotranspiration will be lower with a thick grass mat during spring and fall.

Monitoring for ponding of effluent in the bed is critical, and should be carried out during the parts of the year where Evapotranspiration is low. Bed cleaning could become necessary over time; observation port monitoring data will indicate this.

### ***3.10 Lagoons***

---

#### 3.10.1.1 Lagoon PERFORMANCE STANDARDS

To reduce the possibility of contributing to the creation of a health hazard, lagoons should disperse or evaporate effluent without any surface discharge to ground or water body and should not pollute groundwater. Lagoons should also be located and operated in such a way as to reduce opportunity of disease transmission by vector access (for

example, flies and animals). Water depth should be managed to reduce opportunity for mosquito breeding. Nuisance due to odour should be avoided. Lagoon design addresses maintenance of adequate water depth to prevent freezing of the inlet area during winter conditions. Use and maintain fencing to reduce danger to people and animals.

### 3.10.1.2 LAGOON DESCRIPTION AND PRINCIPLES OF OPERATION

The lagoon system is a method of sewage treatment and disposal. The system consists of one or multiple lagoon cells. The lagoon cell itself is a large and generally rectangular excavation surrounded by a berm. The berm is made by compacting the material excavated from inside the lagoon around its outer edges. Its function is to prevent surface water from entering the cell and overloading it. There should also be a fence on top of the berm to prevent entry into the lagoon area. See Figure 3-37 to Figure 3-40.

Lagoons function as infiltration basins and evaporation ponds. A properly designed and sized lagoon retains effluent long enough to allow for the fluid to enter low porosity soil and provides enough surface area for evaporation to take place.

B.C. zero discharge lagoons are intended for use in areas with net positive evaporation (i.e., where evaporation exceeds rainfall on an annual basis).

### 3.10.1.3 LAGOON DESIGN CONSIDERATIONS

#### *Siting Criteria*

The Authorized Person will determine the number of test pits to be excavated. The recommended minimum number of test pits is two soil observation test pits for 1 to 3 bedroom flows. More will be needed for larger flows. The test pits must conform to the 'Workers Compensation Act Occupational Health and Safety Regulation' (WorkSafe BC), and be of a depth at least 1 m (3') below the bottom of the proposed lagoon (i.e., 3 m (10') deep for a 2 m (6') deep lagoon). The AP should then determine the unsaturated vertical separation, percolation or the soil hydraulic conductivity at the appropriate depths for the lagoon base and the berm area.

A lagoon system should be developed on a site that meets the recommended standards outlined in Table 2-6 and Table 2-7 and has:

- a minimum area of 1.62 ha (4.0 acres);
- a minimum unsaturated vertical depth from the bottom of the lagoon of 0.91 m (36");
- a soil percolation rate equal to or slower than 60 minutes/2.5 cm (1") or Kfs less than 20 mm/day; and,
- a slope no greater than 12% (except where berms are designed by a Professional).

If a lagoon system cannot be constructed on a site meeting this criteria, then the system should be designed or the design reviewed by a professional and the system should be

constructed under the supervision of a professional where the professional considers this to be needed.

Lagoons should be constructed in open areas able to take advantage of airflow to facilitate evaporation.

**General Design**

Septic tanks can be used as a pre-treatment for lagoons.

Septic tanks are used on lagoon systems to reduce solids accumulation and to reduce oils and greases (O&G). Effluent transport pipes to the lagoon are also less likely to clog.

For the purpose of lagoon design, minimum septic tank sizing is determined using two × Daily Design Flow calculated by using Part 2. Common tank sizing is found in Table 3-9.

**Table 3-9 Minimum Septic Tank Sizing for Lagoon Systems**

Daily Design Flow Litres (l gallons)	Septic Tank Sizes Litres (l gallons)
1,136 L/ (250 gal)	2,272 L/ (500 gal)
1,363 L/ (300 gal)	2,726 L/ (600 gal)
1,700 L/ (375 gal)	3,400 L/ (750 gal)
2,045 L/ (450 gal)	4,090 L/ (900 gal)
2,500 L/ (550 gal)	5,000 L/ (1,100 gal)

Effluent can be discharged into the lagoon either by gravity or by pump.

All piping, and fittings should comply with Section 3.5, and pumps should be installed per Section 3.7.7.

The piping should be buried sufficiently to prevent freezing and be installed with “Y” style cleanout at least every 15 m (50').

**Gravity Flow Discharge**

For gravity flow discharge into the lagoon, the septic tank outlet should be higher than the top of the berm to prevent backflow. The difference in elevation between the house sewer outlet and the top of the highest berm should be positive; this is typically at least 45 cm (18").

The minimum recommended slopes for sewer lines carrying raw sewage are:

- 1% for a 4" pipe; and,
- 1.5 % for a 3" pipe.

Pipe cleanouts are strongly recommended in the sewer lines and should be:

- no greater than 15 m (50') apart;
- attached to the sewer line with a sanitary tee or “Y” with a 45° fitting;

- have cleanout caps equipped with cleanout fitting and screw type plug; and,
- cleanout caps should be accessible at the surface grade level.

Where the lagoon is preceded by a septic tank with outlet effluent filter, the filtered effluent is less likely to cause pipe plugging, so the effluent transport line could in this case:

- be installed to achieve a minimum flow velocity of 0.15 m/sec;
- be of smaller diameter (2" or 2.5" nominal); and,
- have no cleanouts.

And the difference in elevation between the septic tank outlet and the top of the highest berm could be reduced to a minimum of 30.5 cm (12").

The sewer pipe or effluent transport line should in all cases:

- extend a minimum of 2 m (6') into the lagoon from the nearest inside wall;
- direct effluent horizontally to the centre of the lagoon; and,
- be positioned securely 30.5 cm (1') above the lagoon bottom.

### *Pumped Discharge*

Pumped discharge should only be used with septic tank pre-treatment.

For discharge pumped into the lagoon, the pump should be designed to maintain a minimum flow velocity of 0.6 m/second (2'/second) through the sewer pipe.

The discharge should be pumped from a separate pump tank or separate pump chamber, and the pipe between the septic tank and pump chamber should be provided with a backflow preventer, with a high level alarm in the pump chamber.

Pump chamber should meet standards of tanks Section 3.6.1, and should be designed to provide reserve volumes, etc. per pressure system 3.7.7.

The forcemain should:

- be fitted with a backflow prevention device that prevents sewage from entering the building;
- be positioned near the centre of the first cell of the lagoon;
- be a minimum of 2 m (78") into the lagoon from the nearest inside wall;
- be securely anchored to the lagoon bottom; and,
- direct influent vertically to the centre of the lagoon.

### Lagoon Sizing

The sizing of a lagoon is dependent on the water balance throughout the year of precipitation, evaporation and soil infiltration. This varies widely over the province. Lagoons do not need the use of a peaking/safety factor for Daily Design Flow due to their large capacity for flow equalization. The following minimum sizing guidelines are provided for lagoons in areas with positive evaporation potentials.

Lagoons should contain one to two years average sewage flow depending on the area in which they are installed and have a minimum surface area to facilitate evaporation.

Table 3-10, Table 3-11 and Table 3-12 provide pre-sized lagoons for 1 – 6 bedroom normal residence use. Other flows should be determined as per Part 2, with average flows being used for lagoon sizing. Over sizing of lagoons is not advisable as this will lead to freezing, choking with emergent vegetation and will encourage mosquito breeding.

Lagoons constructed to contain flows exceeding those outlined in the tables could be sized using the following formula for volume calculation:

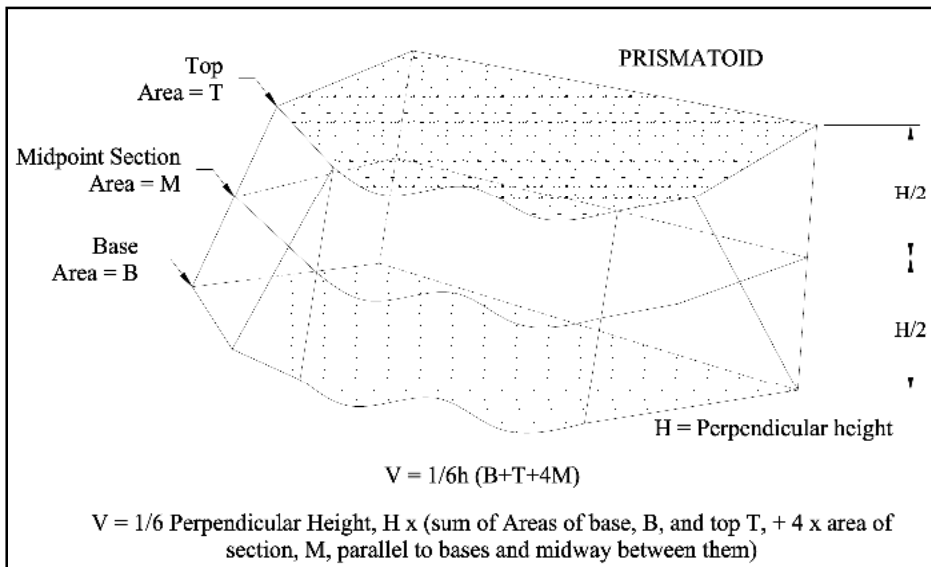

The lagoon sizing in the tables assumes certain lagoon shapes. If other shapes are used or different side slopes are used, it is necessary to check that volume is sufficient and that surface area is at least that in the selected table.

Three lagoon sizing tables are presented. Table 3-10 is for rectangular lagoons in the wetter areas of the B.C. interior, of which Prince George is typical. Infiltration in these regions is more important than evaporation, and in this case two years average flow volume is used for the minimum lagoon retention volume.

Table 3-11 is for rectangular lagoons suitable for drier regions of the B.C. Interior, of which the South Cariboo is typical — the area has rainfall/higher net evaporation, and in this case, one year’s retention at average flow has been found to be sufficient. Lagoons have traditionally been constructed with steeper side slopes in the excavated portion of the lagoon.

Table 3-12 is for deep circular lagoons used in parts of northern B.C., and is based on retention of two years average flow as for Table 3-10.

Where lagoons are sized to hold less than two years average design flow, reserve an area next to the installed cell for a second cell of sufficient size to make up to two years average flow.

Lagoons can also be sized based upon considerations of net evaporation, infiltration and individual site characteristics. However, as these are a low cost system, in many cases the simplified design approach may prove more economical.

**RECTANGULAR LAGOONS, WETTER NORTHERN INTERIOR BC**

Lagoon volume based on two years average flow (1 × one year DDF).

**Table 3-10 Rectangular Lagoon Cell Sizing**

Bedrooms	Estimated Average Daily Flow (Litres/ (I Gallons))	Volume	Depth	Metres (feet)	Total Surface Area	
		CUBIC METERS (CUBIC FT.)	METERS (FEET)	BOTTOM INSIDE METERS (FEET)	TOP INSIDE METERS (FEET)	SQUARE METRES (SQUARE FEET)
1-2	568 (125)	415 (14,951)	3 (10)	14 x 4 (47 x 13)	26 x 16 (87 x 53)	16 4,611
3	682 (150)	508 (18,172)	3 (10)	16 x 5 (53 x 17)	28 x 17 (93 x 57)	476 5,301
4	850 (187)	661 (23,343)	3 (10)	20 x 6 (67 x 20)	32 x 18 (107 x 60)	576 6,420
5	1,023 (225)	777 (27,439)	3 (10)	22 x 7 (73 x 23)	34 x 19 (113 x 63)	646 7,119
6	1,250 (275)	972 (34,326)	3 (10)	24 x 9 (80 x 30)	36 x 21 (120 x 70)	756 8,400

*Note:*  
 Total surface area is the top inside area of berm, not the water surface.  
 Depth is that measured from the top of berm to the inside floor.  
 Volume is the water volume, assuming a minimum of 0.6 m freeboard (2').  
 Side slope internal 2h: 1v  
 SA: Vol ratio is 0.55 to 0.65.

**RECTANGULAR LAGOONS — DRIER NORTHERN INTERIOR BC**

Due to increased evaporation potential lagoon volume equal to one year average flow (0.5 × 1 year DDF). Note steeper side slope in excavated portion. With use of these lagoon sizes, reserve an area for a second cell of sufficient size to make size up to two years average flow next to the installed cell.

**Table 3-11 Rectangular Lagoon Cell Sizing**

Bedrooms	Estimated Average Daily Flow (Litres/ (1 Gallons))	Volume	Depth	Metres (feet)	Total Surface Area	
		CUBIC METERS (CUBIC FT.)	METERS (FEET)	BOTTOM INSIDE	TOP INSIDE	SQUARE METRES (SQUARE FEET)
1 – 2	568 (125)	121	3	6.2 x 4.7	15.2 x 13.7	208
3	682 (150)	255	3	7 x 6	16 x 15	240
4	850 (187)	305	3	8 x 7	17 x 16	272
5	1,023 (225)	389	3	10 x 8	19 x 17	323
6	1,250 (275)	445	3	12 x 8	21 x 17	357

*Note:*  
 Total surface area is the top inside area of berm, not water surface.  
 Depth is measured from the top of berm to the inside floor.  
 Volume is the water volume, assuming a minimum of 0.6 m freeboard (2').  
 Side slope internal 2h: 1v at berm, maximum 1:1 in excavated portion. Above table calculated at avg 1.5h: 1v internal slope.  
 SA: Vol ratio is 0.8 – 1.7.  
 Sizing is based upon South Cariboo Health Region recommendations, but these have been altered to ensure a minimum volume of one year average design flow at maximum water level.

**Figure 3-37 Rectangular Lagoon**

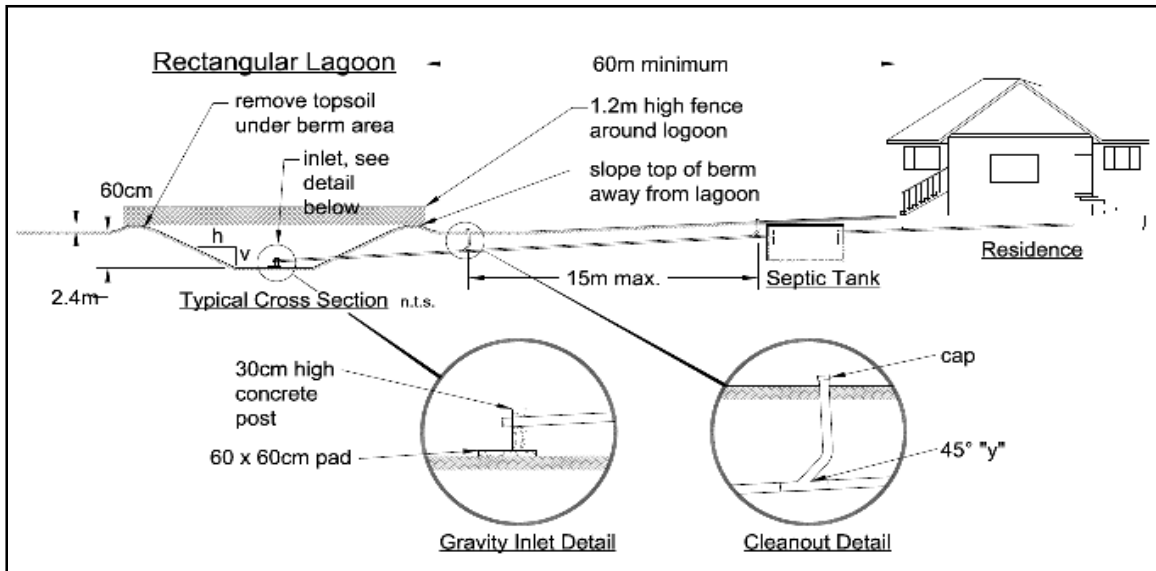

**Figure 3-38 Rectangular Lagoon (top view)**

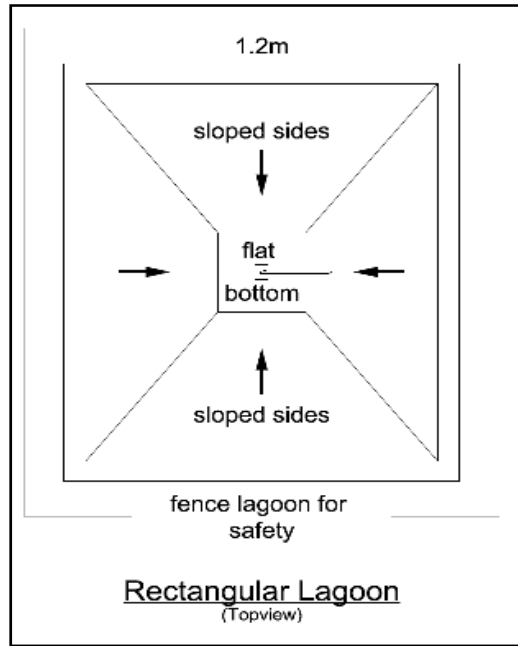

CIRCULAR LAGOONS, NORTHERN B.C.

**Table 3-12 Circular Lagoon Cell Sizing Standards**

Bedrooms	Estimated Average Daily Flow (Litres/ (1 Gallons))	Volume Max. Water level	Depth	Top inside Diameter	Bottom diameter	Total Surface Area
		<b>CUBIC METERS (CUBIC FT.)</b>	<b>METERS (FEET)</b>	<b>METRES (FEET)</b>	<b>METRES</b>	<b>SQUARE METRES (SQUARE FEET)</b>
1 – 2	568 (125)	542 ( )	4 (13)	22 (72)	6	380 (4,090)
3	682 (150)	619 ( )	4 (13)	23 (75)	7	415 (5,113)
4	850 (187)	791 ( )	4 (13)	25 (82)	9	490 (5,274)
5	1,023 (225)	985 ( )	4 (13)	27 (88)	11	572 (6,157)
6	1,250 (275)	1,260 ( )	4 (13)	29.5 (97)	13.5	683 (7,352)

*Note:*  
 Total surface area is the top inside area of berm, not water surface.  
 Depth is that measured from the top of berm to the inside floor.  
 Volume is the water volume, assuming a minimum of 0.6 m freeboard (2').  
 Side slope 2h: 1v.

**Figure 3-39 Circular Lagoon**

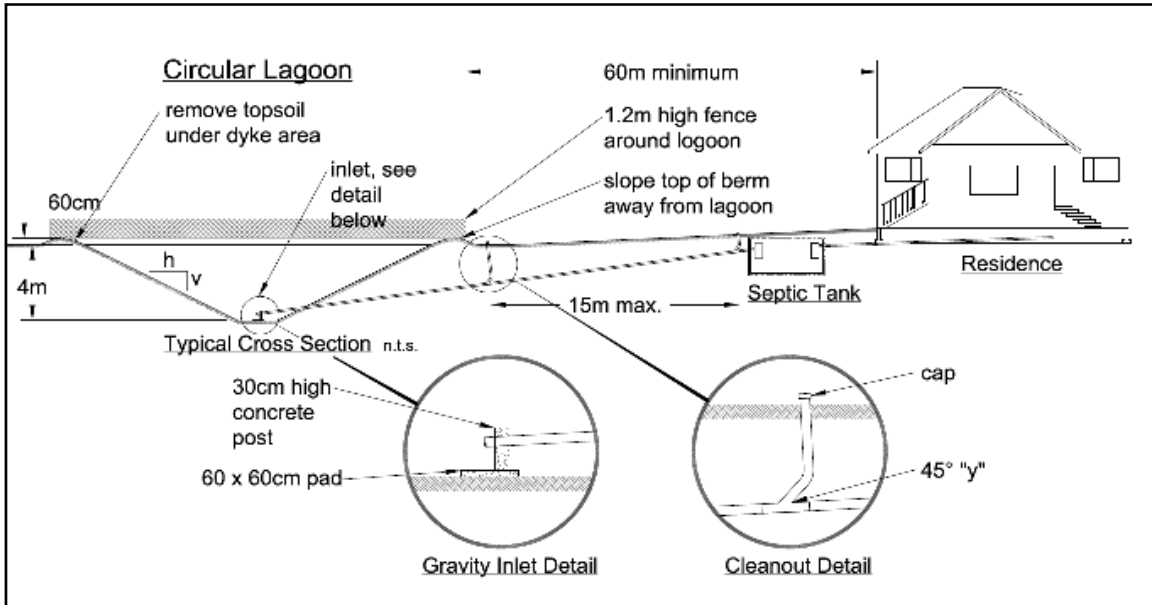

**Figure 3-40 Circular Lagoon (Top View)**

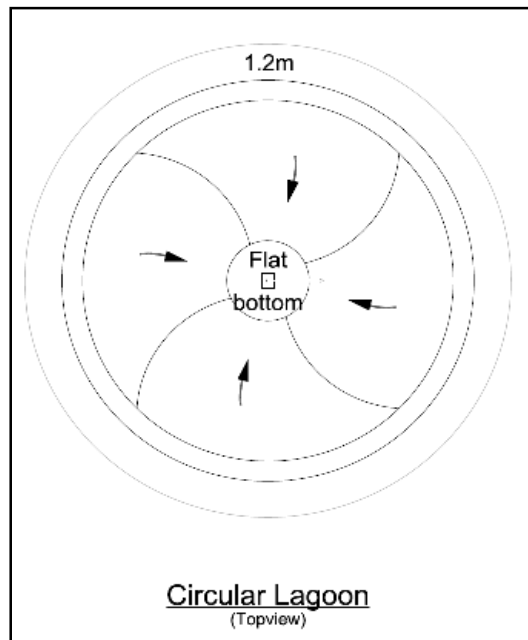

**3.10.1.4 LAGOON SPECIFICATIONS AND INSTALLATION CONSIDERATIONS**

Lagoons should be oriented along the surface contours in order to reduce slope variation. When laying out a lagoon consider potential for future replacement or addition of further cells.

Remove all trees from the lagoon and berm area, and around the lagoon for at least 50' to encourage evaporation.

A lagoon should include the following dimensions:

- have a minimum of 1-2 year retention of the average sewage flow as determined from Part 2 Section 2.2, taking Daily Design Flow from that section and dividing by a peaking factor of 2 to determine average flow;
- the lagoon depth is in accordance with Table 3-5 and Table 3-10 to Table 3-12;
- the berm is 0.9 – 1.5 m (3' – 5') tall;
- the allowable freeboard (height remaining between the lagoon surface and the top of the berm) is a minimum of 0.6 m (2');
- the vertical separation distance, as described in Section 2.3.3.2, is of at least 0.91 m (3'); and,
- on sloped sites the berm could be constructed partially in grade; however, the berm on the lower side should not exceed 1.5 m (5') unless the design is by a professional and construction is supervised by a professional.

The berm should be constructed so that:

- the slopes of the sidewalls are:
  - a maximum of 2v:1h for inside walls of the berm; and,
  - a maximum of 3h:1v for outside walls of the berm;
  - a maximum of 1h:1v for submerged portions of the excavated area, and less where soils will not be stable at this slope when long-term submerged;
- the top of the berm should be no less than 1.2 m (4') in width when fencing is placed on the top of the berm;
- The clay soil making up the berm should be well compacted in 30.5 cm (1') lifts and void of all topsoil and organics;
- The area below the berm should be stripped of all topsoil, organics and soils of permeability >60 min/inch. Where necessary the berm should be keyed to the native soil; and,
- The berm basal area and the completed berm should have a soil percolation rate equal to or slower than 60 minutes/2.5 cm (1") or Kfs less than 20 mm/day.

Freezing potential is greatly reduced by the construction of an internal berm, which increases the depth of water over the pipe and insulates it. The internal berm should be:

- situated  $\frac{1}{3}$  of the distance along the length of the lagoon; and,
- 1.2 m (4') in height.

Surface drainage should be directed away from the base of the berm.

Pumped system considerations per relevant parts of pressure system pump tank specification and installation considerations, Section 3.7.7.4.

### *Fencing*

A fence should be built that:

- completely encloses the lagoon area;
- is made of woven wire or barbed wire
- If barbed wire, to be a minimum of 7 strands with the first strand starting 3 inches from the ground and the following strands spaced evenly;
- is 1.2 m (4') tall; and,
- has access from one side by a locking gate (any gate should be kept locked);
- has signs located on each gate with a warning of “NO TRESPASSING — WASTEWATER LAGOON.”

### 3.10.1.5 LAGOON MAINTENANCE AND MONITORING CONSIDERATIONS

Recommended monitoring and maintenance of a lagoon system includes:

- maintaining the septic tank as per Section 3.6.1.5 (linked standard);
- ensuring that the effluent pump, alarms and controls are in adequate operating condition as per Section 3.7.7.5 pressurized effluent conveyance (linked standard).
- testing alarm operation, including a physical test with float;
- checking all plumbing fittings and ensure that piping is in operating condition;
- assessing structural integrity of polymer-based access lids;
- measuring level of water in lagoon and recording level below berm top;
- maintaining fencing and controlling vegetation growth including both emergent aquatic vegetation and trees/shrubs that may reduce evaporation potential.

Where the lagoon consistently exceeds the maximum freeboard level, enlargement is necessary through construction of a new cell or a new lagoon.

## Index

- Above ground sand-lined trenches, 168
- Adjacent property, 8
- Aggregate, 105, 144, 171, 175
  - Specifications, 107
- Air/vacuum valve, 121
- AIS. *See* Area of infiltrative surface
- Alarm, 139
- Alarm reserve volume, 131
- Alternating drainfields, 49
- Alternating fields
  - Site capability, 52
- Animal guard, 158
- Apparent Opening Size (AOS), 108
- Area of infiltrative surface, 38, 103, 145
- ASTM standard C33-97, 42
- At grade bed system, 100, 104, 144–48
  - Bed and pipe network
    - Design considerations, 146–47
  - Contours and concave slopes
    - Design considerations, 146
  - Description and principles of operation, 145
  - Design considerations, 145–47
  - Maintenance and monitoring, 148
  - Performance standards, 144
  - Specifications and installation, 147–48
  - Trenches, 106
- Authorized Person, 2, 59
  - Roles and responsibilities, 12
- Average daily flow, 59
- Backflow preventer, 181
- Basal area, 38, 167
  - Preparation, 170
  - Vegetation, 171
- Bedrooms, 19
- Bentonite, 106, 158
- Biomat, 32, 40, 101, 119, 120, 147, 148, 149, 151, 154, 168, 174, 176
- BOD, 54, 68
- Boundaries, 30
- Boundary performance, 30–38
- Building paper, 105
- C33, 42, 70, 105, 175
- Capping, 105, 108
- Chemicals, 55
- Chisel ploughs, 171
- Chlorine, 56
- Cleaning chemicals, 26
- Cleanout, 82
- Cleanouts, 134, 135
- Climate
  - ET beds, 73
  - ETA beds, 73
  - Freezing, 73
  - Lagoons, 73
  - Rainfall, 73
  - Site constraint, 73
- Cold weather, 135
- Colluvial, 71
- Commercial kitchen, 21
- Commissioning, 138
- Community well, 35
- Concave slope, 29
- Concave slopes, 146
- Confined space, 69, 83, 136
- Connections and piping
  - Description and principles of operation, 75–78
  - Design considerations, 79–80
  - Gravity sewers, 75
  - Maintenance and monitoring, 83
  - Performance standards, 75
  - Piping
    - specification and installation, 80–82
  - Sewage ejector pumps
    - specification and installation, 82–83
  - Specifications and installation, 80–83
- Covenants. *See* Restrictive covenants
- Cover
  - Maximum, 106
- Cover soil, 105, 106
- Critical standards, 3
- Critical Standards, 15, 16
- Cross over, 113
- Crusting, 108
- CSA standard, 92
  - Septic tanks, 86
- Curtain drains, 155
- Daily design flow, 17–27, 42, 59

- Flow records, 26
- Letter of certification, 26
- Peak flow, 17
- Peaking factor, 19, 20
- Datalogger, 153
- Datalogging, 56
- Demand dosing
  - Pump tank volumes, 131
- Design
  - SWIS, 59–61
- Disinfectant cleaning chemicals, 26
- Disinfectants, 55
- Distribution, 128
- Distribution valve, 113
- Dosed gravity distribution system, 113–19
  - Description and principles of operation, 113–17
  - Pressure manifold, 118
  - Pump to d-box, 117
  - Serial or sequential distribution, 118
- Dosing
  - Frequency, 127, 128
- Dosing and distribution
  - Criteria, 127
- Drain back, 131
- Drain rock, 105
  - Specifications, 107
- Drawdown, 139, 140
- Drinking water, 35, 36
- Drop boxes, 113
- Drywell, 141
- Easement
  - Site plan, 61
- Easements, 9, 30, 60
- ed gravity distribution system
  - Pressure manifold, 118
- Effective bed width, 146
- Effluent filter, 54, 68, 87, 129
  - Access, 88
  - Alarm, 88
- Effluent flow, 157
- Electrical criteria, 138
- Equalization, 154
- Erosion, 144, 157, 160, 170
- ETA and ET bed, 174–78
  - Critical site and soil standards, 177–78
  - Description and principles of operation, 175–76
  - Maintenance and monitoring, 178
  - Performance standards, 174–75
  - Site capability, 50, 52
  - Specifications and installation, 176–78
- Evapotranspiration bed. See ETA and ET bed, See ETA and ET bed
- Evapotranspiration/absorbtion bed. See ETA and ET bed, See ETA and ET bed
- Existing systems
  - Repair or replacement, 9
- Fecal coliform, 54
- Fencing, 179
- Field sampling manual, 67
- File, 6
- Filing return, 7
- Fill, 29
- Float, 140
- Float setting worksheet, 130
- Float switch, 137
- Floating outlet device, 133
- Floating outlet systems, 138
- Flood plain, 53
  - Lagoon, 53
  - trench or bed system, 53
- Flood-dose, 113
- Floor area, 18
- Flotation, 93
- Flow, 67
  - Monitoring, 67, 101
  - Peak, 54, 55
  - Recording metres, 56
  - Septic tank, 85
  - Velocity, 121
- Flow equalization, 20, 85, 91, 96, 133
- Flow reduction, 27
- Flushing, 139, 141
- Freezing, 73, 81, 135
- Fresh water, 35
  - Defined, 36
  - seasonal, 36

- Seasonal, 35
- Garbage grinders, 27, 88
- Garburators. *See* Garbage grinders
- Geotextile, 105, 108, 144, 147, 157, 170
  - Specifications, 107
- Graded aggregate filter, 105, 170, 176
- Graded filter, 172
- Gravelless chamber, 166
  - Effective trench width, 104
- Gravelless effluent dispersal system, 108
- Gravity sewers, 75, 81
- Gravity system, 142
- Gravity systems
  - Dosed, size, 110
  - Site capability, 52
  - Trickling, size, 110
- Gravity Systems
  - Dosed, 52
- Gravity trench distribution system, 110–13
  - Description and principles of operation, 110
  - Design considerations, 101–2
  - Distribution box, 110–11
  - Monitoring and maintenance, 113
  - Specifications and installation, 111–12
- Grease interceptor, 27, 85, 90
- Grease interceptors
  - Mechanical, 91
  - minimum detention time, 91
  - Monitoring, 91
- Grinder pump, 80, 88
- Groundwater mounding, 156
- Groundwater table, 44
- HAR, 127, 149, 154, 167, 168
- Hay or straw, 105
- Health Act*, 1
- Health Authority
  - Roles and responsibilities, 11
- High level alarm, 137, 181
- High-strength waste, 21, 56
- HLR, 38–44, 59, 145
  - At grade bed, 39
  - Basal area, 40
  - Sand media, 42
- Sand mound, 40, 42
- Sand-lined trench, 40
- Seepage bed, 39
- Horizontal separation, 71
- Horizontal setback, 59, 157
  - Critical setbacks, 34
  - Interception drain, 36
  - Other boundaries, 37
  - Perimeter, 35
  - Reduction in setback to well or source of drinking water, 36
  - Site plan, 61
  - Subsurface drains, 35
- Hydraulic conductivity, 41
- Hydraulic loading rate, 38–44
- Hydraulic Loading Rate. *See* HLR
- Hydrogen sulphide, 111
- Inceptisols, 51, 71, 105
- Indexing valve, 119
- Infiltration, 96
- Infiltration bed, 142
- Infiltrative surface, 102
- Installation, 62
  - Post installation certification, 62
- Installer
  - Maintenance and monitoring
    - Roles and responsibilities, 63
- Instantaneous loading rate, 127, 154
- Lagoon, 28, 29, 36, 43, 67, 178–88
  - Description and principles of operation, 179
  - Design considerations, 179–86
  - Fencing, 188
  - General design, 180
  - Gravity flow discharge, design, 180–81
  - Maintenance and monitoring, 188
  - Performance standards, 178–79
  - Pumped discharge, design, 181
  - Site capability, 50, 52
  - Siting criteria, design, 180
  - Sizing
    - Circular, 185–86
    - Rectangular, dry conditions, 185
    - rectangular, wet conditions, 183
  - Sizing, design, 182–86

- Specifications and installation, 186–88
- Lateral
  - Diameter, 122
- Letter of certification, 7, 13, 62
  - Post installation certification, 62
- Limiting layer, 71
- Linear loading rate (LLR). *See* LLR
- Linked Standards, 5, 16
- LLR, 44–49, 59, 71, 145
  - Where LLR standards cannot be met, 45
- Loading rates, 41
- Low level alarm, 137
- Luxury homes, 19, 20
- Macro fauna, 154
- Macropores, 105, 108, 147, 171, 175
- Maintenance
  - Overview, 62–69
  - Owner’s responsibilities, 14
- maintenance and Monitoring
  - Frequency of, 66
- Maintenance and Monitoring
  - Overview, 62–69
- Maintenance plan, 56, 62, 64, 65
- Maintenance Plan, 13
- Maintenance Provider
  - Maintenance and monitoring roles and responsibilities, 63
- Manifolds, 122
- Marine, 35
- Mass loading, 17, 20, 26, 27, 42
- Membrane, 156
- Moh’s scale, 107
- Moisture holding capacity, 152, 167
- Moisture monitoring, 153, 154
- Monitoring, 40, 64
  - Discharge area, 56
  - Flow, 67
  - Overview, 62–69
  - Requirements, 68
  - Treatment facilities, 56
- Mound sand, 42, 43, 105, 171, 175
- MSR. *See* Municipal Sewage Regulation
- Multiple homes, 11
- Municipal Sewage Regulation, 55
- National Sanitation Foundation (NSF), 96
- Nitrogen, 54
- Notice to occupant, 66
- Nutrient reduction, 56
- Observation ports, 109, 176
- Occupants, 19
- Oil and grease, 27, 54
- On-demand pump dosing, 121
- Organic soils, 50
- Orifice, 122
  - Diameter, 122
  - Orientation, 134
  - Shields, 134
  - Spacing, 109, 122
- Owner
  - Maintenance and monitoring Roles and responsibilities, 63
  - Roles and responsibilities, 13
- Oxygen diffusion, 161
- Oxygen flux, 48
- Pathogen, 54
- Pea gravel, 171
- Peak flow, 17
- Peat, 50
- Penetrometer, 173
- Perched high water table
  - PHWT, 28
- Percolation rates, 41
- Percolation test, 28
  - Minimum number, 29
- Performance, 30
- Permeameter test, 28
  - Minimum number, 29
- pH, 54
- Phosphorus, 54
- Pipes, 113
- Piping, 75–83
  - Expansion and contraction, 82
  - Pressure, 81
  - Pressure testing, 81
  - Support, 81
- Planner
  - Maintenance and monitoring Roles and responsibilities, 63
- Planning, 59–61

- Plumbing code, 81
- Power availability, 74
- Prescription drugs, 26
- Pressure distribution, 106, 165
  - At grade bed system, 145
  - Raised bed system, 145
  - Site capability, 50
- Pressure manifold
  - Principles, 116
  - Specifications and installation, 118
- Pressure piping, 81
- Pressure sensor, 137
- Pressure system design worksheet, 130
- Pressure systems
  - Site capability, 52
- Pressure testing, 81
- Pressured effluent distribution
  - Commissioning, 138
- Pressurized distribution, 71
- Pressurized effluent distribution, 120–41
  - Cold weather criteria
    - Specifications and installation, 135
  - Commissioning and testing
    - Specifications and installation, 138–39
  - Description and principles of operation, 120–21
  - Design considerations, 121–29
  - Dosing and distribution
    - Design considerations, 127–29
  - Effluent pump
    - Specifications and installation, 136
  - Electrical criteria
    - Specifications and installation, 138
  - Float switch and sensors
    - Specifications and installation, 137
  - High level alarm
    - Specifications and installation, 136–37
  - Low level alarm
    - Specifications and installation, 137
  - Maintenance and Monitoring, 139–41
  - Orifices
    - Specifications and installation, 134–35
  - Plumbing criteria
    - Specifications and installation, 136–37
- Pump tank
  - Specifications and installation, 136
- Pump tank demand dosing
  - Design considerations, 131–32
- Pump tank sizing
  - Design considerations, 133
- Pump tank timed dosing
  - Design considerations, 132–33
- Siphon and floating outlets
  - Specifications and installation, 138
- Siphon systems
  - Design considerations, 134
- Sloping sites
  - Design considerations, 123–27
  - Specifications and installation, 134–39
- Testing, 138
- Trench criteria
  - Specifications and installation, 134
- Zones
  - Design considerations, 129
- Primary pre-treatment, 83
- Prismatoid, 182
- Privies, 3
- Process selection, 69–74
- Professional, 2, 4, 6, 9, 12, 15, 16, 21, 26, 35, 36, 40, 44, 46, 49, 57, 71, 73, 96, 142, 150, 165, 171, 177, 179, 187
- Defined, 12
- Hydrogeologist/geotechnical, 35
- Property lines, 38
- PSND trench, 148–53
  - Description and principles of operation, 149–51
  - Design considerations, 151–52
  - Maintenance and monitoring, 153
  - Performance standard, 148–49
  - Specifications and installation, 152–53
- Pump
  - Counter, 140
  - Cycle counter, 56, 140
  - Dosing, on-demand, 121
  - Dosing, timed, 121

- Effluent, 136
- Ejector, 79
- Flow rate, 139
- Grinder, 79
- Maintenance, 83
- Raw wastewater, 79
- Run time, 140
- Sewage, 79
- Pump removal, 136
- Pump run time, 139
- Pump tank
  - Pressurized effluent distribution
    - Maintenance and monitoring, 139
    - Treatment plant, 131
- Pump tank sizing worksheet, 130
- Pump to d-box
  - Principles, 113
  - Specifications and installation, 117
- Rainfall, 177
- Raised
  - Trenches, 106
- Raised bed system, 145, 144–48
  - Bed and pipe network
    - Design considerations, 146–47
  - Contours and concave slopes
    - Design considerations, 146
  - Description and principles of operation, 145
  - Design considerations, 145–47
  - Maintenance and monitoring, 148
  - Performance standards, 144
  - Specifications and installation, 147–48
- Relief, 113
- Relief drains, 156
- Repair, 9
  - Component, 9
  - Emergency, 9
  - System, 10
- Replacement, 9
- Reserve, 183
- Reserve volume, 131, 133
- Residential sewage*, 53
  - Standards*, 17, 54
- Residual, 71
- Residual head, 122, 141
- Restrictive covenants, 8, 9, 30, 60
  - On adjacent property, 8
  - Site plan, 61
- Reverse osmosis, 55
- Ring infiltrometer, 29
- Riser, 83
- Rock, 51
- Rock pit, 141
- Root intrusion, 135
- Rototillers, 171
- Safety, 69, 179
- Safety Factor, 20
- Sand media
  - Alternate sand specifications, 43
  - Uniform density, 172
- Sand mound, 73
  - Basal HLR, 40
  - Horizontal setback, 38
  - LLR, 45
  - Sand media depth, 34
  - Site capability, 50, 52
- Sand mounds and sand-lined trenches, 160–74
  - Above ground trenches, 174
  - Aggregate, 171
  - Concave slopes, 169
  - Cover soil, 172
  - Description and principles of operation, 161–64
  - Design considerations, 164–69
  - Geotextile or filter, 172
  - Maintenance and monitoring, 174
  - Mound sand, 171–72
  - Observation ports, 173
  - Performance standards, 160
  - Preparation of the basal area, 170–71
- Sand mounds
  - Dosing and distribution, 168
  - Steps of design process, 167
- Sand-lined trenches
  - Steps of design process, 168
  - Specifications and installation, 170–74
  - Uniform density for sand media, 172–73
- Sand-lined trench

- Basal HLR, 40
- LLR, 45
- Sand media depth, 34
- Site capability, 50
- Sanitary Regulations, 36
- Saprolites, 51, 71, 105
- SAR, 54, 55, 56
- SDD system, 153–55
  - Moisture monitoring, 154–55
  - Vertical separation, special case, 155
- Seal, 7
- Seasonal dwellings, 11
- Seasonal high water table. *See* SHWT
  - SHWT, 28, 29
- Seasonal use, 74
- Sedimentation, 87
- Seepage bed, 142–44
  - Bed dimensions, 143
  - Bed sizing, 142
  - Construction, 144
  - Description and principles of operation, 142
  - Design criteria, 142–43
  - Maintenance and monitoring, 144
  - Site criteria, 142
  - Specifications and installation, 143–44
- Seepage beds
  - Site capability, 52
- Septic tank, 68
- Septic tank effluent gravity system. *See* STEG
- Septic tank effluent pump. *See* STEP
- Septic tank grinder pump (GP), 76
- Septic tank sizing
  - For lagoon systems, 180
- Sequential distribution
  - Principles, 113
  - Specifications and installation, 118
- Serial distribution
  - Principles, 113
  - Specifications and installation, 118
- Settlement, 85
- Sewage Disposal Regulation, 10
- Sewer
  - Minimum grade, 81
- Sewerage System Regulation, 1
- SHWT, 34
  - Seasonal high water table, 28
- Siphon system, 133, 138
- Siphon systems, 140
  - Pressurized effluent distribution monitoring and maintenance, 140
- Siphoning, 121
- Site capability, 49–53, 69–74
- Site drainage, 155–59
  - Description and principles of operation, 156–57
  - Design considerations, 157
  - Maintenance and monitoring, 158–59
  - Performance standards, 155–56
  - Specifications and installation, 158
- Site investigation, 27, 59
- Site plan, 60
  - North meridian, 60
  - Scale, 60
  - Scale bar, 60
- Site/soil
  - Evaluation report, 13
- Siting, 29
- Slope, 43
  - Concave slope, 73
  - Location, 72
  - Low slope, 72
  - Site constraint, 72–73
  - Slope shape, 72
  - Steep slope, 72
  - Very steep slope, 72
- Slope stability, 160
- Sloping sites, SWIS, 159–60
  - Design considerations, 159
  - Specifications and installation, 160
- Small diameter variable slope sewers, 76
- Snifter tube, 140
- Sodium, 54, 56
- Sodium adsorption ratio. *See* SAR
- Soil
  - Coarse fragment content, 71
  - Colluvial, 71
  - Depth, 70
  - Inceptisols, 71
  - Investigation, 61

- Investigation water table, 27
- Macro fauna, 99, 149, 154
- Moisture, 170
  - Site capability, 52
- Residual, 71
- Saprolites, 71
- Soil characteristics, 27
- Texture, 28
- Soil profile, 28
  - Colour, 28
  - Consistence, 28
  - Gleying, 28
  - Mottling, 28
  - Redoximorphic, 28
  - Rupture resistance, 28
  - Structure, 28
- Source control policy, 53
- Splitter tees, 110
- Squirt height, 122, 141
- Standard Practice, 13
  - Defined, 5
- STEG, 76, 80
- STEP, 76
- Subdivisions, 3
  - Method 2
    - Reserve Area, 188
- Subsurface dam, 157
- Subsurface wastewater infiltration systems. See SWIS
- Surge flow, 55, 79, 88, 91
- Swale, 106, 146, 157, 158, 160
- Swimming pools, 38
- SWIS, 59, 98–160
  - Ecosystem considerations, 101
  - Pressurized effluent distribution monitoring and maintenance, 140
  - Site considerations, 101
  - Soil considerations, 101
- System selection, 49–53
- Technical Review Committee**, 2
- Testing, 138
- Timed dosing, 42, 128, 148, 167
  - Pump tank volumes, 132
  - Site capability, 50
- Timed pump dosing, 121
- Timer allow volume, 132
- Tipping diverters, 110
- Title block, 61
- Treatment, 161
- Treatment facilities, 83–98
- Trench dispersal system
  - Aggregate, 105
  - Aggregate specifications, 107
  - At grade, 106
  - Cover, 105–6
  - Description and principles of operation, 102–3
  - Design criteria, 103–4
  - Drain rock depth, 105
  - Geotextile specifications, 107–8
  - Observation ports and vents, 109
  - Shallow, 106
  - Shallow and at grade trenches, 106
  - Specifications and installation, 105–9
- Trench dispersal technologies, 102–9
- Trickling failure, 140
- TSS, 54, 68, 176
- Type 1 system
  - Access opening, 92–93
  - Description and principles of operation, 84–85
  - Design considerations, 91
  - Detention time, 88
  - Effluent, 53, 55
  - Effluent filters, 87–88
  - Effluent standards, 17, 54
  - Flotation, 93
  - Flow equalization, 91
  - Gravity distribution, 33
  - Grease interceptor, 90–91
  - Groundwater, 93
  - Performance standards, 83–84
  - Pressure distribution, 33
  - Septic tank abandonment, 95
  - Settlement, 85
  - Size and shape guidelines, 87
  - Venting, 84, 93
  - Volume requirements, 88–90
  - Watertightness testing, 91
  - Working volume, 88
- Type 2 10/10, 42
  - Effluent, 56, 149

- HLR, 56
- Site capability, 50
- Subsurface drip dispersal, 155
- Type 2 and 3 systems
  - Description and principles of operations, 96
  - Design considerations, 96–97
  - Maintenance and monitoring, 97–98
  - Performance standards, 96
  - Specifications and installation, 97
- Type 2 system, 11
  - Effluent, 55, 67, 167
  - Pressure distribution, 33
  - Site capability, 52
  - Treatment, 56
- Type 3 system, 11, 21, 40
  - Effluent, 55, 67, 149, 167
  - Pressure distribution, 33
  - Subsurface drip dispersal, 155
  - Treatment, 56, 71
- Unsaturated conditions, 30, 99, 154
- Vacuum breaker, 137
- Vacuum system, 76, 80
- Vegetation, 106
- vent
  - Screen, 82
- Vent, 109
  - D-box, 111
- Venting, 84, 93, 97
  - Screens, 97
- Vertical separation, 69, 71, 105, 165
  - Increasing, 31
  - Sand mounds and sand-lined trenches, 33
  - Standards, 30
  - Subsurface drip dispersal, 155
  - Trench and bed systems, 32
- Vertical separation, gravity systems
  - C33 sand layer, 105
- Water holding capacity, 152, 167
- Water lines, 38
- Water softener, 55
- Water table, 29
- Water table mounding, 46
- Watertight, 97
- Watertightness testing, 91
- Wax, 26, 55
- Well, 35, 37, 59
  - Community, 36
  - High pumping, 35, 36
  - Site plan, 61
- Working volume, 88
- Zone and distributing valves
  - Hydraulic distributing valve
    - specification and installation, 119–20
- Zones and distributing valves, 119–20
  - Alternating fields
    - specifications and installation, 120
- Zones and alternating fields
  - Maintenance and monitoring, 120

## List of Appendices

- Appendix A Glossary of Terms
- Appendix B *Sewerage System Regulation, Health Act*
- Appendix C Design Inputs Worksheet
- Appendix D Mass Loading: Flow Reduction Devices
- Appendix E Recommendation for Field Tests of Soil Permeability
  - Percolation Test
  - Soil Hydraulic Conductivity (K) Test
- Appendix F Performance at Boundaries, Increases to Vertical Separation
- Appendix G Design HLR
- Appendix H Sand Mound Systems
- Appendix I Expanding Clay Soils
- Appendix J Source Control Policy from BCOSSA Maintenance Plan Template
- Appendix K Sodium, Salinity and Water Softeners
- Appendix L Terminology for System Operation and Malfunction
- Appendix M Piping Materials
- Appendix N Surge Flows for Fixtures and Trap Sizes
- Appendix O Testing Tanks for Water tightness
- Appendix P Pressure Distribution Network Design
- Appendix Q Hydraulic Application Rate, Distribution
- Appendix R Temporary industrial camps
- Appendix S Soil Evaluation Log forms

## Sources cited

The manual may contain extracts from published materials. We have attempted to request permission where appropriate and to acknowledge in the text all sources of such material. We wish to make specific reference here to the authors, publishers, journals and institutions that have been generous in giving their permission to reproduce works in this manual. If we have inadvertently overlooked any acknowledgment, we undertake to rectify the omission in any future revisions.

## Source of figures used in the manual

All figures in the manual were drawn for the manual, in some cases these are adapted from figures in published documents; the list below gives reference to those sources.

In all cases where figures have been based upon source figures the figure has been substantially altered and not simply copied.

Figures created for the manual by or for the BCOSSA TRC without reference to any particular source are indicated by the abbreviation “TRC”. These diagrams are considered by the TRC to be released to the public domain.

Figures re-used or re-drawn from the SPM Version 1 are indicated by the abbreviation “SPM V1”.

**Figure 2-1** Vertical Separation between the Infiltrative Surface and the Restrictive Layer.

Adapted from US EPA Onsite Wastewater Treatment Systems Manual, 2002

**Figure 2-2** Linear Loading Rate on a Slope, Showing Trench Cross Sections

TRC

**Figure 2-3** How Effluent Flows Away from a Discharge Area, and How this Affects LLR

Adapted from “Wisconsin Mound Soil Absorption System: siting, design and construction manual” by J. Converse and E. Tyler, 2000.

**Figure 3-1** System Selection in Relation to Soil Depth

Adapted from US EPA Onsite Wastewater Treatment Systems Manual, 2002, PD

**Figure 3-2** Diagram: STEP System Schematic Plan and Individual Connection

Adapted from Crites and Tchobogous, Small and Decentralized Wastewater Management Systems, 1998

**Figure 3-3** Diagram: Other Collector Systems, Showing Individual Connections

Adapted from Crites and Tchoboglous, *Small and Decentralized Wastewater Management Systems*, 1998

**Figure 3-4** Compartmentalized Septic Tank.

TRC

**Figure 3-5** Flow in a Septic Tank.

TRC

**Figure 3-6** Septic Tank with Multiple Compartments Provided by Individual Tanks, and Pump Chamber in Third Compartment.

TRC

**Figure 3-7** A SWIS Trench System, Showing Terminology

Adapted from US EPA Onsite Wastewater Treatment Systems Manual, 2002, PD

**Figure 3-8** Trench Dispersal Layout

TRC

**Figure 3-9** Vent and Combination Vent and Observation Port Examples

TRC

**Figure 3-10** Gravity Trench Distribution

SPM V1

**Figure 3-11** Distribution Box

SPM V1

**Figure 3-12** Serial System (Top and Side Views)

TRC

**Figure 3-13** Sequential (Drop Box) System (Top View)

TRC

**Figure 3-14** Sequential (Drop Box) System (Side View)

TRC

**Figure 3-15** Pressure Distribution System

TRC

**Figure 3-16** Tee to Tee Manifold, with Check Valves.

TRC

**Figure 3-17** Cross Manifold, with Check Valves.

TRC

**Figure 3-18** Short Upslope Header Manifold, with Feeder Pipes to Laterals.

TRC

**Figure 3-19** Short Downslope Header Manifold, with Check Valves.

TRC

**Figure 3-20** Pump Tank Nomenclature: Showing Piping Layout Suitable for Areas Where Heavy Frost Is Not Encountered.

TRC

**Figure 3-21** Schematic of Demand Dosing Terms

TRC

**Figure 3-22** Schematic of Timed Dosing Terms: Showing Example of Tank with Lag Float

TRC

**Figure 3-23** Seepage Bed Pressure Dispersal Typical Cross Section

TRC

**Figure 3-24** At Grade Bed Typical Cross Section

Adapted from Wisconsin At Grade component manual, 1999

**Figure 3-25** Shallow Narrow Drainfield Cross Sections

Upper diagram Adapted from University of Rhode Island diagram, lower, TRC

**Figure 3-26** Use of an Interception Drain

TRC

**Figure 3-27** Trench Depth Variance on Sloped Site

SPM V1

**Figure 3-28** Example of a Mound Cross Section Showing Nomenclature

TRC

**Figure 3-29** Sand-lined Trench

Adapted from Washington State Department of Health Sand Lined Trench System Guidelines

**Figure 3-30** Sand-lined Trench with High Permeability Soils to Surface, Option 1

Adapted from Washington State Department of Health Sand Lined Trench System Guidelines

**Figure 3-31** Sand-lined Trench with High Permeability Soils to Surface, Option 2

Adapted from Washington State Department of Health Sand Lined Trench System Guidelines

**Figure 3-32** Sand-lined Trench to Reach Suitable Soil at Depth

Adapted from Washington State Department of Health Sand Lined Trench System Guidelines

**Figure 3-33** Above Ground Sand-lined Trench

Adapted from Washington State Department of Health Sand Lined Trench System Guidelines

**Figure 3-34** Mound Layout Schematic.

TRC, mound layout nomenclature is conceptually based upon methods described in Wisconsin Mound Soil Absorption System: siting, design and construction manual” by J. Converse and E. Tyler, 2000.

**Figure 3-35** Horizontal Setbacks are Measured from the Edge of the Minimum Basal Area of the Mound

Adapted from Washington State Department of Health Sand Mound System Guidelines

**Figure 3-36** Calculation of Effective Bed Length on Site with Concave Contour

Adapted from Wisconsin Mound component manual, 2001

**Figure 3-37** Rectangular Lagoon

TRC

**Figure 3-38** Rectangular Lagoon (top view)

TRC

**Figure 3-39** Circular Lagoon

TRC

**Figure 3-40** Circular Lagoon (Top View)

TRC

## **Figures used in the Appendices to the manual**

### **Figure A-1** Hillside Profile Positions

Adapted from Field Book for Describing and Sampling Soils, Version 2.0, USDA, 2002.  
PD

### **Figure A-2** Geomorphic Landscape Positions

Adapted from Field Book for Describing and Sampling Soils, Version 2.0, USDA, 2002.  
PD

### **Figure A-3** Slope Shape Diagrams

Adapted from Field Book for Describing and Sampling Soils, Version 2.0, USDA, 2002.  
PD

### **Figure A-4** Cross section of a dispersal trench, showing design boundaries.

Adapted from US EPA Onsite Wastewater Treatment Systems Manual, 2002, PD

### **Figure A-5** An onsite system, showing some design and compliance boundaries

Adapted from US EPA Onsite Wastewater Treatment Systems Manual, 2002, PD